

IAMGOLD[®]

C O R P O R A T I O N

TECHNICAL REPORT ON THE WESTWOOD COMPLEX, QUÉBEC, CANADA

Prepared by:

Mr. Bernard Haley, P.Eng., IAMGOLD	Mr. Louis Nkoy Manda Mbomba, P.Eng., IAMGOLD
Mr. Abderrazak Ladidi, P.Geo., IAMGOLD	Dr. Ali Jalbout, P.Eng., ASA Geotech Inc.
Mr. Martin Perron, P.Eng., Norda Stelo Inc.	Mr. Steve Pelletier, P.Eng., IAMGOLD

Dates:

Effective date:	30 September, 2024
Filing date:	9 January, 2025

CERTIFICATE OF QUALIFIED PERSON

I, Bernard Haley, P.Eng., am employed as Westwood's Mine Manager with IAMGOLD Corporation (IAMGOLD), with an office address at 150 King Street West, Suite 2200, Toronto, ON, Canada M5H 1J9.

This certificate applies to the technical report titled "Technical Report on the Westwood Complex, Québec, Canada" that has an effective date of September 30, 2024 (the "technical report").

I am a Professional Engineer registered with the Order of Engineers of Quebec (OIQ No. 5088805) and the Professional Engineers of Ontario (PEO No. 100506173). I graduated from McGill University in 2007 with a Bachelor of Engineering.

I have practiced my profession for 17 years. My relevant experience for the purpose of the Technical Report is:

- Iamgold – Westwood Complex – Mine Manager;
- Iamgold – Westwood Complex – Technical Services Superintendent;
- Kirkland Lake Gold – Macassa Mine – Mine Superintendent;
- Newmont – Éléonore Mine – Mine Superintendent;
- Goldcorp – Éléonore Mine – Production Improvement Superintendent;
- Goldcorp – Éléonore Mine – Engineering Superintendent;
- Goldcorp – Éléonore Mine – Production Coordinator;
- Goldcorp – Musselwhite Mine – Production Coordinator;
- Goldcorp – Musselwhite Mine – Projects Planner;
- Goldcorp – Musselwhite Mine – Mine Planner.

As a result of my experience and qualifications, I am a Qualified Person as defined in National Instrument 43–101 *Standards of Disclosure for Mineral Projects* (NI 43–101) for those sections of the technical report that I am responsible for preparing.

I am currently employed at the Westwood Complex and have been since 2021. This serves as my scope of personal inspection.

I am responsible for Sections 1.1, 1.2 (cost estimates), 1.3, 1.4, 1.5, 1.9, 1.10, 1.16, 1.17, 1.19, 1.20, 1.21, 1.22, 1.23, 1.24, 1.25; Sections 2.1, 2.2, 2.3, 2.4.1, 2.6, 2.7; Section 3; Section 4; Section 5; Section 6; Section 12.3.1; Section 13; Section 17; Section 18; Section 19; Section 21; Section 22; Section 23, Section 24; Sections 25.1, 25.2, 25.3, 25.4, 25.8, 25.9, 25.13, 25.14, 25.15, 25.17, 25.18, 25.19, 25.20, 25.21; Section 26 and Section 27 of the technical report.

I am not independent of IAMGOLD as independence is described by Section 1.5 of NI 43–101.

I have been involved with the Westwood Complex since 2021, in my role as Mining Manager.

I have read NI 43-101 and the sections of the technical report for which I am responsible have been prepared in compliance with that Instrument.

As of the effective date of the technical report, to the best of my knowledge, information and belief, the sections of the technical report for which I am responsible contain all scientific and technical information that is required to be disclosed to make those sections of the technical report not misleading.

Dated: 9 January, 2025

“Signed and sealed”

Bernard Haley, P.Eng.

CERTIFICATE OF QUALIFIED PERSON

I, Abderrazak Ladidi, P.Geo., am employed as a Principal Resource Geologist with IAMGOLD Corporation (IAMGOLD), with an office address at 150 King Street West, Suite 2200, Toronto, ON, Canada M5H 1J9.

This certificate applies to the technical report titled “Technical Report on the Westwood Complex, Québec, Canada” that has an effective date of September 30, 2024 (the “technical report”).

I am a Professional Geologist of ‘Ordre des Géologues du Québec’ (OGQ No. 1265), I am also a member of the Professional Geoscientists Ontario (PGO No. 2812). I graduated from the university of Morocco in 1999 with a B.Sc. in Geology and from University of Quebec in Abitibi-Témiscamingue in Rouyn-Noranda (UQAT) in 2011 with a DESS degree in Engineering.

I have practiced my profession of geologist continuously for 17 years. During that time, I have been involved in mineral exploration, mine geology (underground and open pit), ore control and resource modelling projects for gold, copper, zinc, silver and iron properties in Canada.

As a result of my experience and qualifications, I am a Qualified Person as defined in National Instrument 43–101 *Standards of Disclosure for Mineral Projects* (NI 43–101) for those sections of the technical report that I am responsible for preparing.

I am currently employed at the Westwood Complex and have been since 2020. This serves as my scope of personal inspection.

I am responsible for Sections 1.1, 1.2 (Grand Duc Mineral Resource estimate only), 1.3, 1.6, 1.7, 1.8, 1.9, 1.11.2, 1.12 (Grand Duc Mineral Resource estimate only), 1.23.2, 1.25; Sections 2.1, 2.2, 2.3, 2.4.2, 2.5, 2.6; Section 7; Section 8; Section 9; Section 10 (excepting Section 10.8); Section 11; Sections 12.1, 12.2, 12.3.2; Sections 14.2, 14.3.2, 14.4, 14.5; ; Sections 25.1, 25.5, 25.6, 25.7, 25.8, 25.10, 25.20.2, Section 26 and Section 27 of the technical report.

I am not independent of IAMGOLD as independence is described by Section 1.5 of NI 43–101.

I have been involved with the Westwood Complex since 2020, in my role as Principal Resource Geologist.

I have read NI 43–101 and the sections of the technical report for which I am responsible have been prepared in compliance with that Instrument.

As of the effective date of the technical report, to the best of my knowledge, information and belief, the sections of the technical report for which I am responsible contain all scientific and technical information that is required to be disclosed to make those sections of the technical report not misleading.

Dated: 9 January, 2025

“Signed and sealed”

Abderrazak Ladidi, P.Geol.

CERTIFICATE OF QUALIFIED PERSON

I, Martin Perron, am employed as a Director, Centre of Excellence, Geology with Norda Stelo Inc., with an office address at 725, Boulevard Lebourgneuf, Suite 310-17, Quebec City, Quebec, Canada, G2J 0C4.

This certificate applies to the technical report titled “Technical Report on the Westwood Complex, Québec, Canada” that has an effective date of September 30, 2024 (the “technical report”).

I am a member of the Ordre des Ingénieurs du Québec (OIQ No. 109185) and a member of the Professional Engineers Ontario (PEO No.100629167). I graduated with a bachelor’s degree in Geological Engineering from Université du Québec A Chicoutimi (UQAC, Ville de Saguenay, Quebec) in 1992.

I have practiced my profession for 30 years. I have been directly involved in mining geology, mineral exploration, consultation and resource estimation, mainly in gold, base metals and potash, and accessory in graphite and rare earth elements since graduating from university. During my career, I have held multiple positions, starting as Mine Geologist, Geological Mining Coordinator, Senior Geological Engineer, Geology Superintendent, Engineering Superintendent, Technical Services Superintendent, Director of Resources Estimation and Director of Geology, as well as being Qualified Person since 2010. My expertise was acquired while working with Placer Dome, Cambior, Breakwater Resources, Genivar, Alexis Minerals, Richmond Mines, Agrium, Roche Ltee, Goldcorp, Newmont, IAMGOLD and InnovExplo. I have been the Director of Geology for InnovExplo Inc. since October 2021 which transitioned into Norda Stelo in May 2024.

As a result of my experience and qualifications, I am a Qualified Person as defined in National Instrument 43–101 *Standards of Disclosure for Mineral Projects* (NI 43–101) for those sections of the technical report that I am responsible for preparing.

I have not visited the Westwood Property for the purpose of that technical report.

I am responsible for Sections 1.1, 1.2 (Westwood Mineral Resource estimate excluding stockpiles only), 1.3, 1.9, 1.11.1, 1.12 (Westwood Mineral Resource estimate excluding stockpiles only), 1.25; Sections 2.1, 2.2, 2.3, 2.5, 2.6; Sections 10.8, 10.9; Section 12.3.3; Sections 14.1, 14.3.1 (Westwood Mineral Resource estimate excluding stockpiles only), 14.4, 14.5; Sections 25.1, 25.8, 25.10 (Westwood Mineral Resource estimate excluding stockpiles only); Section 26 and Section 27 of the technical report.

I am independent of IAMGOLD Corporation as independence is described by Section 1.5 of NI 43–101.

I have been involved with the Westwood Property since 2020 regarding mineral resources estimation with my previous position at lamgold and my current position.

I have read NI 43–101 and the sections of the technical report for which I am responsible have been prepared in compliance with that Instrument.

As of the effective date of the technical report, to the best of my knowledge, information and belief, the sections of the technical report for which I am responsible contain all scientific and technical information that is required to be disclosed to make those sections of the technical report not misleading.

Dated: 9 January 2025

“Signed and sealed”

Martin Perron, P.Eng.

CERTIFICATE OF QUALIFIED PERSON

I, Louis Nkoy Manda Mbomba, P.Eng. am employed as Superintendent Mine Engineering with IAMGOLD Corporation (IAMGOLD), with an office address at 150 King Street West, Suite 2200, Toronto, ON, Canada M5H 1J9.

This certificate applies to the technical report titled “Technical Report on the Westwood Complex, Québec, Canada” that has an effective date of September 30, 2024 (the “technical report”).

I am a Professional Engineer of Ordre des ingénieurs du Québec; (OIQ No. 138772). I graduated from Laval University in 2005 with a B.Sc.Eng. Degree in Mining Engineer.

I have practiced my profession for 19 years since graduation. I have been directly involved in:

- Since 2020, I have been responsible for the Engineering department at the Westwood Complex;
- Assistant Mine Engineering superintendent at the Eleonore mine (Newmont);
- Chief Mine Engineer for the Richmond (Beaufor mine), including support for preparation of a technical report on that operation.

As a result of my experience and qualifications, I am a Qualified Person as defined in National Instrument 43–101 *Standards of Disclosure for Mineral Projects* (NI 43–101) for those sections of the technical report that I am responsible for preparing.

I currently work at the Westwood Complex and have since 2020. This familiarity with the operations serves as my scope of personal inspection.

I am responsible for Sections 1.1, 1.2 (Mineral Resource estimate in stockpiles for Westwood mine only; Mineral Reserve estimates, life-of mine plan), 1.3, 1.9, 1.12 (Mineral Resource estimate in stockpiles for Westwood mine only), 1.13, 1.14, 1.15 (excepting geotechnical information for Westwood mine), 1.17 (stockpiles and waste rock storage facilities only), 1.25; Sections 2.1, 2.2, 2.3, 2.4.3, 2.5, 2.6; Section 12.3.4; Sections, 14.3.1 (Mineral Resource estimate in stockpiles only); Section 15; Section 16 (excepting geotechnical information for Westwood mine); Sections 18.3, 18.4, Section 20.5; Sections 25.1, 25.8, 25.10 (Mineral Resource estimate in stockpiles for Westwood mine only), 25.11, 25.12 (excepting geotechnical information for Westwood mine), 25.14 (stockpiles and waste rock storage facilities only), Section 26 and Section 27 of the technical report.

I am not independent of IAMGOLD as independence is described by Section 1.5 of NI 43–101.

I have been involved with the Westwood Complex since 2020 in my role as Superintendent Mine Engineering.

I have read NI 43–101 and the sections of the technical report for which I am responsible have been prepared in compliance with that Instrument.

As of the effective date of the technical report, to the best of my knowledge, information and belief, the sections of the technical report for which I am responsible contain all scientific and technical information that is required to be disclosed to make those sections of the technical report not misleading.

Dated: 9 January 2025

“Signed and sealed”

Louis Nkoy Manda Mbomba, P.Eng.

CERTIFICATE OF QUALIFIED PERSON

I, Ali Jalbout, am employed as a Principal Geotechnical Specialist with ASA Geotech, with an office address at 35 Rue Hans Selye, Kirkland Quebec, Canada H9J 3W4.

This certificate applies to the technical report titled “Technical Report on the Westwood Complex, Québec, Canada” that has an effective date of September 30, 2024 (the “technical report”).

I am a Professional Engineer of the Ordre des Ingénieurs du Québec (OIQ No. 6010434) and a member of the Professional Engineers Ontario (PEO No. 100121550). I graduated with a bachelor’s degree in civil engineering from Damascus University in 1997, and from the University of Science and Technologies in Lille USTL- France with a Master and Doctorate degrees in geotechnical engineering in 2005.

I have practiced my profession for 22 years. I have been directly involved in geotechnical engineering and mining since graduating from university. During my career, I have held multiple positions, starting as engineer site supervisor, ground control engineer, rock mechanics engineer, senior rock mechanics engineer, senior ground control engineer, geotechnical technical expert, and geotechnical manager. My expertise was acquired while working with Inco, Goldcorp, Xstrata (then Glencore), Freeport McMoran, Newmont, IAMGOLD and ASA Geotech. I have been the Geotechnical Principal Specialist for ASA Geotech Inc. since November 2021.

As a result of my experience and qualifications, I am a Qualified Person as defined in National Instrument 43–101 *Standards of Disclosure for Mineral Projects* (NI 43–101) for those sections of the technical report that I am responsible for preparing.

I most recently visited the Westwood Operations on 2 October, 2024, a duration of a day.

I am responsible for Sections 1.1, 1.3, 1.9, 1.15.1 (geotechnical information for Westwood mine only), 1.23.1 (seismicity only), 1.25; Sections 2.1, 2.2, 2.3, 2.4.4, 2.6; Section 12.3.5; Section 16.2.1; Sections 25.1, 25.8, 25.12 (geotechnical information for Westwood mine only), 25.20.1 (seismicity only); Section 26 and Section 27 of the technical report.

I am not independent of IAMGOLD Corporation as independence is described by Section 1.5 of NI 43–101.

I have been involved with the Westwood Complex since 2020, firstly until 2021 as an IAMGOLD employee, and since November 2021 as an independent geotechnical specialist consultant.

I have read NI 43–101 and the sections of the technical report for which I am responsible have been prepared in compliance with that Instrument.

As of the effective date of the technical report, to the best of my knowledge, information and belief, the sections of the technical report for which I am responsible contain all scientific and technical information that is required to be disclosed to make those sections of the technical report not misleading.

Dated: 9 January 2025

“Signed and sealed”

Ali Jalbout, PhD., P.Eng.

CERTIFICATE OF QUALIFIED PERSON

I, Steve Pelletier, P.Eng., am employed as a Director Environment with IAMGOLD Corporation (IAMGOLD), with an office address at 150 King Street West, Suite 2200, Toronto, ON, Canada M5H 1J9.

This certificate applies to the technical report titled “Technical Report on the Westwood Complex, Québec, Canada” that has an effective date of September 30, 2024 (the “technical report”).

I am a Professional Engineer of Ordre des Ingénieurs du Québec (OIQ No. 118317). I graduated from Sherbrooke University in December 1996 with a bachelor’s degree in Chemical Engineering.

I have practiced my profession for 27 years. My relevant experience in environment, water treatment, tailing management, closure plan, Emergency response and permitting for the purpose of the Technical Report is:

- Iamgold – Corporation – Environment Director
- Iamgold – Westwood Complex
 - Sustainable Development Manager and Environment Superintendent
- Glencore - Horne Smelter
 - Environment Superintendent, Energy efficiency and Atmospheric emissions Supervisor and Senior Metallurgist
- Glencore – CEZinc
 - Jarofix (tailing) Supervisor, Hazmat technician/Coordinator and Metallurgist

As a result of my experience and qualifications, I am a Qualified Person as defined in National Instrument 43–101 *Standards of Disclosure for Mineral Projects* (NI 43–101) for those sections of the technical report that I am responsible for preparing.

I most recently visited the Westwood Complex from August 26–29, 2024, a duration of four days.

I am responsible for Sections 1.1, 1.3, 1.9, 1.18, 1.25; Sections 2.1, 2.2, 2.3, 2.4.5, 2.5, 2.6, Section 12.3.6; Section 20; Sections 25.1, 25.8, 25.16, Section 26 and Section 27 of the technical report.

I am not independent of IAMGOLD as independence is described by Section 1.5 of NI 43–101.

I have been involved with the Westwood Complex since 2020, firstly as the Sustainable Development Manager for the operations, and since 2023, as IAMGOLD’s corporate Environment Director.

I have read NI 43–101 and the sections of the technical report for which I am responsible have been prepared in compliance with that Instrument.

As of the effective date of the technical report, to the best of my knowledge, information and belief, the sections of the technical report for which I am responsible contain all scientific and technical information that is required to be disclosed to make those sections of the technical report not misleading.

Dated: 9 January, 2025

“Signed and sealed”

Steve Pelletier, P.Eng.

TABLE OF CONTENTS

1	SUMMARY	1-1
1.1	Introduction.....	1-1
1.2	Key Outcomes	1-1
1.3	Terms of Reference	1-2
1.4	Project Setting	1-2
1.5	Mineral Tenure, Surface Rights, Water Rights, Royalties and Agreements	1-3
1.6	History	1-4
1.7	Geology and Mineralization.....	1-4
1.8	Drilling and Sampling.....	1-5
1.9	Data Verification.....	1-7
1.10	Metallurgical Testwork.....	1-7
1.11	Mineral Resource Estimation.....	1-8
1.11.1	Westwood.....	1-8
1.11.2	Grand Duc.....	1-10
1.12	Mineral Resource Statement.....	1-11
1.13	Mineral Reserve Estimation.....	1-18
1.13.1	Westwood.....	1-18
1.13.2	Grand Duc.....	1-18
1.14	Mineral Reserve Statement.....	1-19
1.15	Mining Methods	1-23
1.15.1	Westwood.....	1-23
1.15.2	Grand Duc.....	1-26
1.16	Recovery Methods.....	1-26
1.17	Project Infrastructure	1-28

1.18	Environmental, Permitting and Social Considerations.....	1-29
1.18.1	Environmental Considerations.....	1-29
1.18.2	Closure and Reclamation Planning.....	1-29
1.18.3	Permitting Considerations	1-30
1.18.4	Social Considerations	1-30
1.19	Markets and Contracts	1-31
1.20	Capital Cost Estimates	1-31
1.21	Operating Cost Estimates	1-32
1.22	Economic Analysis	1-32
1.23	Risks and Opportunities.....	1-32
1.23.1	Risks	1-32
1.23.2	Opportunities.....	1-35
1.24	Interpretation and Conclusions	1-35
1.25	Recommendations.....	1-36
2	INTRODUCTION	2-1
2.1	Introduction.....	2-1
2.2	Terms of Reference	2-1
2.3	Qualified Persons.....	2-2
2.4	Site Visits and Scope of Personal Inspection.....	2-3
2.4.1	Mr. Bernard Haley.....	2-3
2.4.2	Mr. Abderrazak Ladidi.....	2-3
2.4.3	Mr. Louis Nkoy Manda Mbomba	2-3
2.4.4	Dr. Ali Jalbout.....	2-4
2.4.5	Mr. Steve Pelletier	2-4
2.5	Effective Dates.....	2-4
2.6	Information Sources and References.....	2-5

2.7	Previous Technical Reports.....	2-5
3	RELIANCE ON OTHER EXPERTS.....	3-1
4	PROPERTY DESCRIPTION AND LOCATION	4-1
4.1	Location.....	4-1
4.2	Ownership	4-1
4.3	Mineral Tenure.....	4-1
4.3.1	Doyon-Westwood Property	4-1
4.3.2	Fayolle Property.....	4-4
4.3.3	Legal Surveys	4-14
4.4	Surface Rights.....	4-14
4.5	Water Rights.....	4-14
4.6	Royalties and Encumbrances.....	4-14
4.7	Permitting Considerations	4-14
4.8	Environmental Considerations	4-15
4.9	Social Considerations.....	4-15
4.10	QP Comment on Item 4 “Property Description and Location”	4-15
5	ACCESSIBILITY, CLIMATE, LOCAL RESOURCES, INFRASTRUCTURE AND PHYSIOGRAPHY...	5-1
5.1	Accessibility	5-1
5.2	Climate	5-2
5.3	Local Resources and Infrastructure	5-2
5.4	Physiography	5-2
5.5	Sufficiency of Surface Rights.....	5-3
6	HISTORY.....	6-1
6.1	Ownership, Exploration, and Development History	6-1
6.2	Production History.....	6-1
7	GEOLOGICAL SETTING AND MINERALIZATION.....	7-1

7.1	Regional Geology.....	7-1
7.1.1	Overview.....	7-1
7.1.2	Southern Volcanic Zone	7-2
7.2	Local Geology	7-8
7.2.1	Doyon-Westwood Property	7-8
7.2.2	Fayolle Property.....	7-11
7.3	Deposits.....	7-13
7.3.1	Westwood.....	7-13
7.3.2	Grand Duc.....	7-25
8	DEPOSIT TYPES	8-1
8.1	Introduction.....	8-1
8.2	Deposit Type Description.....	8-1
8.2.1	Orogenic Gold Deposits	8-1
8.2.2	Gold-Rich VMS Deposits	8-2
8.3	QP Comment on Item 8 “Deposit Types”	8-2
9	EXPLORATION.....	9-1
9.1	Grids and Surveys.....	9-1
9.1.1	Westwood.....	9-1
9.1.2	Grand Duc.....	9-1
9.1.3	Fayolle.....	9-1
9.2	Geological Mapping.....	9-1
9.2.1	Westwood.....	9-1
9.2.2	Grand Duc.....	9-1
9.2.3	Fayolle.....	9-2
9.3	Geochemical Sampling	9-2
9.3.1	Westwood.....	9-2

9.3.2	Grand Duc.....	9-2
9.3.3	Fayolle.....	9-2
9.4	Geophysical Surveys.....	9-4
9.4.1	Westwood.....	9-4
9.4.2	Grand Duc.....	9-6
9.4.3	Fayolle.....	9-6
9.5	Exploration Potential.....	9-9
10	DRILLING.....	10-1
10.1	Introduction.....	10-1
10.2	Drill Methods.....	10-13
10.2.1	Doyon-Westwood Property.....	10-13
10.2.2	Fayolle Property.....	10-13
10.3	Geological Logging.....	10-13
10.3.1	Doyon-Westwood Property.....	10-13
10.3.2	Fayolle Property.....	10-15
10.4	Recovery.....	10-15
10.4.1	Doyon-Westwood Property.....	10-15
10.4.2	Fayolle Property.....	10-15
10.5	Collar Surveys.....	10-15
10.5.1	Doyon-Westwood Property.....	10-15
10.5.2	Fayolle Property.....	10-16
10.6	Down Hole Surveys.....	10-16
10.6.1	Doyon-Westwood Property.....	10-16
10.6.2	Fayolle Property.....	10-17
10.7	Sample Length/True Thickness.....	10-17
10.8	Drilling Since Westwood Database Close-Out Date.....	10-20

10.9	QP Comment on Item 10 “Drilling”	10-20
11	SAMPLE PREPARATION, ANALYSES AND SECURITY.....	11-1
11.1	Sampling Methods.....	11-1
11.1.1	Geochemical Sampling.....	11-1
11.1.2	Core Sampling.....	11-1
11.1.3	Grade Control Sampling.....	11-3
11.1.4	Underground Channel Sampling	11-3
11.2	Density Determinations.....	11-3
11.3	Analytical and Test Laboratories.....	11-4
11.3.1	Doyon-Westwood Property	11-4
11.3.2	Fayolle Property.....	11-5
11.4	Sample Preparation.....	11-6
11.4.1	Doyon-Westwood Property	11-6
11.4.2	Fayolle Property.....	11-6
11.5	Analysis.....	11-6
11.5.1	Doyon-Westwood Property	11-6
11.5.2	Fayolle Property.....	11-6
11.6	Quality Assurance and Quality Control.....	11-8
11.6.1	Doyon-Westwood Property	11-8
11.6.2	Fayolle Property.....	11-12
11.7	Databases.....	11-12
11.7.1	Doyon-Westwood Property	11-12
11.7.2	Fayolle Property.....	11-13
11.8	Sample Security.....	11-13
11.8.1	Doyon-Westwood Property	11-13
11.8.2	Fayolle Property.....	11-13

11.9	QP Comment on Item 11 “Sample Preparation, Analyses and Security”	11-14
12	DATA VERIFICATION	12-1
12.1	Internal Verification.....	12-1
12.2	External Verification	12-1
12.2.1	Previous Technical Reports	12-1
12.2.2	Other Reviews.....	12-1
12.3	Verification by Qualified Persons	12-2
12.3.1	Mr. Bernard Haley.....	12-2
12.3.2	Mr. Abderrazak Ladidi.....	12-2
12.3.3	Mr. Martin Perron.....	12-3
12.3.4	Mr. Louis Nkoy Manda Mbomba	12-4
12.3.5	Dr. Ali Jalbout.....	12-4
12.3.6	Mr. Steve Pelletier	12-5
13	MINERAL PROCESSING AND METALLURGICAL TESTING	13-1
13.1	Introduction.....	13-1
13.2	Gold Metallurgical Testwork.....	13-1
13.3	Zinc and Copper Metallurgical Testwork	13-2
13.4	Recovery Estimates	13-2
13.5	Metallurgical Variability.....	13-3
13.6	Deleterious Elements	13-3
14	MINERAL RESOURCE ESTIMATES	14-1
14.1	Westwood	14-1
14.1.1	Introduction.....	14-1
14.1.2	Structure Review.....	14-1
14.1.3	Models and Domains	14-1
14.1.4	Capping.....	14-3

14.1.5	Compositing.....	14-4
14.1.6	Density.....	14-7
14.1.7	Variography	14-7
14.1.8	Grade Interpolation	14-10
14.1.9	Block Model Validation	14-16
14.1.10	Confidence Classification	14-20
14.1.11	Reasonable Prospects of Eventual Economic Extraction.....	14-21
14.1.12	Reconciliation	14-23
14.2	Grand Duc.....	14-24
14.2.1	Introduction.....	14-24
14.2.2	Models and Domains	14-24
14.2.3	Capping.....	14-26
14.2.4	Compositing.....	14-27
14.2.5	Density.....	14-27
14.2.6	Variography	14-27
14.2.7	Grade Interpolation	14-28
14.2.8	Confidence Classification	14-28
14.2.9	Block Model Validation	14-30
14.2.10	Reasonable Prospects of Eventual Economic Extraction.....	14-30
14.3	Mineral Resource Statement.....	14-32
14.3.1	Westwood.....	14-32
14.3.2	Grand Duc.....	14-32
14.3.3	Westwood and Grand Duc.....	14-32
14.4	Factors that May Affect the Mineral Resource Estimates.....	14-37
14.5	QP Comment on Item 14 “Mineral Resource Estimates”	14-38
15	MINERAL RESERVE ESTIMATES	15-1

15.1	Introduction.....	15-1
15.2	Westwood	15-1
15.2.1	Development Of Mining Case	15-1
15.2.2	Cut-off Grades.....	15-2
15.2.3	Dilution and Mining Recovery	15-2
15.3	Grand Duc.....	15-3
15.3.1	Pit Optimization	15-3
15.3.2	Cut-off Grades.....	15-4
15.3.3	Dilution and Mining Recovery	15-4
15.4	Mineral Reserves Statement	15-5
15.5	Factors that May Affect the Mineral Reserve Estimate	15-5
15.6	QP Comment on Item 15 “Mineral Reserve Estimates”	15-9
16	MINING METHODS	16-1
16.1	Introduction.....	16-1
16.2	Westwood	16-1
16.2.1	Geotechnical Considerations	16-1
16.2.2	Hydrological Considerations	16-11
16.2.3	Operations	16-11
16.2.4	Life-of-Mine Plan	16-21
16.2.5	Ore Control	16-21
16.2.6	Blasting	16-22
16.2.7	Equipment	16-22
16.3	Grand Duc.....	16-23
16.3.1	Geotechnical Considerations	16-23
16.3.2	Hydrological Considerations	16-25
16.3.3	Operations	16-25

16.3.4	Ore Control	16-27
16.3.5	Blasting	16-27
16.3.6	Life-of-Mine Plan	16-27
16.3.7	Equipment	16-28
17	Recovery Methods.....	17-1
17.1	Introduction.....	17-1
17.2	Flowsheet	17-1
17.3	Plant Design.....	17-4
17.3.1	Ore Handling and Crushing	17-4
17.3.2	Grinding and Gravity	17-4
17.3.3	Leaching and Adsorption	17-5
17.3.4	Cyanide Destruction.....	17-5
17.3.5	Paste Backfill	17-5
17.3.6	Gold Recovery.....	17-5
17.4	Tailings Disposal	17-6
17.5	Energy, Water, and Process Materials Requirements.....	17-6
17.5.1	Reagents and Consumables	17-6
17.5.2	Plant Services.....	17-6
17.5.3	Power.....	17-6
17.5.4	Water	17-7
18	Project Infrastructure	18-1
18.1	Introduction.....	18-1
18.2	Roads and Logistics.....	18-2
18.3	Stockpiles	18-2
18.4	Waste Rock Storage Facilities	18-7
18.5	Tailings Storage Facilities.....	18-7

18.6	Water Supply	18-7
18.7	Water Management	18-7
18.8	Built Infrastructure	18-7
18.9	Camps and Accommodation.....	18-7
18.10	Power and Electrical	18-7
18.11	Natural Gas.....	18-8
19	Market Studies and Contracts	19-1
19.1	Market Studies	19-1
19.2	Commodity Price Projections	19-1
19.3	Contracts	19-1
19.4	QP Comment on Item 19 “Market Studies and Contracts”	19-2
20	Environmental Studies, Permitting, and Social or Community Impact	20-1
20.1	Baseline and Supporting Studies	20-1
20.2	Environmental Considerations and Monitoring Programs.....	20-1
20.2.1	Site Management and Monitoring.....	20-1
20.2.2	Water Management.....	20-3
20.3	Mine Closure Requirements and Costs.....	20-4
20.4	Permitting.....	20-7
20.4.1	Initial Permitting	20-7
20.4.2	Current Permitting	20-7
20.5	Waste Rock Storage Facilities	20-11
20.6	Tailings Storage Facility	20-12
20.7	Social and Community Impact	20-12
20.7.1	First Nations.....	20-12
20.7.2	Westwood and Grand Duc.....	20-13
21	Capital and Operating Costs	21-1

21.1	Introduction.....	21-1
21.2	Capital Cost Estimates	21-1
21.2.1	Exploration, Valuation, and Definition Drilling.....	21-1
21.2.2	Underground Infrastructure	21-1
21.2.3	Process Plant.....	21-1
21.2.4	Closure Costs	21-2
21.2.5	Capital Cost Estimate Summary	21-2
21.3	Operating Costs	21-2
21.3.1	Mining.....	21-2
21.3.2	Processing.....	21-3
21.3.3	Environmental	21-3
21.3.4	Administration	21-4
21.3.5	Operating Cost Estimate Summary	21-4
22	Economic Analysis	22-1
23	Adjacent Properties	23-1
24	Other Relevant Data and Information	24-1
25	Interpretation and Conclusions	25-1
25.1	Introduction.....	25-1
25.2	Project Setting	25-1
25.3	Ownership	25-1
25.4	Mineral Tenure, Surface Rights, Water Rights, Royalties and Agreements	25-1
25.5	Geology and Mineralization.....	25-1
25.6	History and Exploration	25-2
25.7	Drilling, and Sampling.....	25-2
25.8	Data Verification.....	25-2
25.9	Metallurgical Testwork.....	25-2

25.10	Mineral Resource Estimates	25-3
25.11	Mineral Reserve Estimates	25-4
25.12	Mining Methods	25-5
25.13	Recovery Methods.....	25-5
25.14	Infrastructure	25-5
25.15	Market Studies	25-6
25.16	Environmental, Permitting and Social Considerations.....	25-6
25.17	Capital Cost Estimates	25-7
25.18	Operating Cost Estimates	25-7
25.19	Economic Analysis	25-7
25.20	Risks and Opportunities.....	25-7
25.20.1	Risks	25-7
25.20.2	Opportunities.....	25-8
25.21	Conclusions.....	25-8
26	Recommendations.....	26-1
27	References.....	27-1

LIST OF TABLES

Table 1-1:	Mineral Resource Statement, Westwood	1-12
Table 1-2:	Mineral Resource Statement, Grand Duc.....	1-16
Table 1-3:	Mineral Resource Statement, Westwood and Grand Duc	1-17
Table 1-4:	Mineral Reserves Statement, Westwood.....	1-20
Table 1-5:	Mineral Reserves Statement, Grand Duc	1-22
Table 1-6:	Mineral Reserves Statement, Westwood and Grand Duc	1-22
Table 1-7:	Westwood Complex - Mine Plan Summary.....	1-33
Table 4-1:	Doyon-Westwood Property Mineral Claims and Mining Leases	4-5
Table 4-2:	Fayolle Project Mineral Claims and Mining Leases	4-10
Table 6-1:	Doyon-Westwood Property History	6-2
Table 6-2:	Fayolle Property History	6-3
Table 6-3:	Production History	6-4
Table 7-1:	Stratigraphic Table, Doyon-Westwood Property	7-3
Table 7-2:	Stratigraphic Table, Fayolle Property	7-4
Table 7-3:	Westwood Mine Lithologies	7-14
Table 7-4:	Mineralized Corridors	7-20
Table 7-5:	Phases, Mooshla Intrusive Complex.....	7-26
Table 7-6:	Grand Duc Mineralization	7-29
Table 10-1:	Project Drill Summary Table	10-2
Table 10-2:	Drill Summary Table, Westwood	10-2
Table 10-3:	Drill Summary Table, Grand Duc–Doyon	10-4
Table 10-4:	Drill Summary Table, Mouska.....	10-6
Table 10-5:	Drill Summary Table, Fayolle	10-8
Table 11-1:	Sample Preparation Methods, Doyon-Westwood.....	11-7
Table 11-2:	Analytical Methods, Doyon-Westwood.....	11-7
Table 13-1:	Comminution Testwork Result Ranges.....	13-4
Table 14-1:	Gold Assay Statistics	14-5
Table 14-2:	Grade Capping Values	14-5
Table 14-3:	Uncapped Gold Composite Statistics.....	14-6
Table 14-4:	Capped Gold Composite Statistics.....	14-6
Table 14-5:	Density by Group of Mineralized Lenses and Buffers	14-8

Table 14-6:	MIK Cut-off Thresholds for WW28A (rock code 220)	14-11
Table 14-7:	MIK Cut-Off Thresholds For All Selected Lenses	14-13
Table 14-8:	Estimation Parameters	14-14
Table 14-9:	Optimizing Coefficients for the MIK Lenses.....	14-17
Table 14-10:	DSO Sub-Shape Scenarios.....	14-22
Table 14-11:	Input Parameters Used to Calculate the Underground Cut-off Grade.....	14-23
Table 14-12:	Comparison between Block Models and Mill by Interpolation Method	14-24
Table 14-13:	Models and Domains, Grand Duc.....	14-25
Table 14-14:	Grade Capping, Grand Duc	14-27
Table 14-15:	Estimation Parameters	14-29
Table 14-16:	Input Parameters, Constraining Pit Shell, Grand Duc	14-31
Table 14-17:	Mineral Resource Statement, Westwood.....	14-33
Table 14-18:	Mineral Resource Statement, Grand Duc.....	14-36
Table 14-19:	Mineral Resource Statement, Westwood and Grand Duc.....	14-37
Table 15-1:	Westwood Input Parameters, Break-even Cut-off Grade.....	15-3
Table 15-2:	Optimization Parameters, Grand Duc.....	15-4
Table 15-3:	Mineral Reserves Statement, Westwood	15-6
Table 15-4:	Mineral Reserves Statement, Grand Duc	15-8
Table 15-5:	Mineral Reserves Statement, Westwood and Grand Duc	15-8
Table 16-1:	In Situ Stresses for Numerical Modelling.....	16-2
Table 16-2:	Intact Rock Parameters	16-3
Table 16-3:	Joint Families	16-3
Table 16-4:	Rock Quality Index and Rock Quality Parameters.....	16-4
Table 16-5:	Major Seismic Events in 104 Central Infrastructure Corridor	16-4
Table 16-6:	Risk Assessment Strategy	16-6
Table 16-7:	Mitigation Planning	16-8
Table 16-8:	LOM Plan, Westwood and Grand Duc	16-22
Table 16-9:	Equipment Requirements, Westwood	16-23
Table 16-10:	Geotechnical Parameters, Grand Duc	16-25
Table 16-11:	Equipment List, Grand Duc.....	16-29
Table 20-1:	Major Environmental Studies.....	20-2
Table 20-2:	Closure Plans and Updates	20-6

Table 20-3:	Key Permits	20-8
Table 21-1:	Summary of Capital Expenditures, Westwood (\$ million)	21-3
Table 21-2:	Westwood Complex – Mine Plan Summary	21-5

LIST OF FIGURES

Figure 1-1:	Westwood Mineral Resources Classification.....	1-14
Figure 1-2:	Westwood Mineral Reserve Classification, Including Indicated Mineral Resources Not Converted to Mineral Reserves	1-21
Figure 1-3:	Westwood Seismic Events History	1-24
Figure 2-1:	Project Location Map	2-2
Figure 4-1:	Mining Operation Location Map	4-2
Figure 4-2:	Doyon-Westwood Property.....	4-3
Figure 4-3:	Doyon-Westwood Mineral Title Location Map.....	4-9
Figure 4-4:	Fayolle Mineral Title Location Map	4-13
Figure 7-1:	Regional Geology Map	7-2
Figure 7-2:	Project Area Geology Map	7-5
Figure 7-3:	Legend Key to Accompany Figure 7-2.....	7-6
Figure 7-4:	Geological and Metallogenic Evolution	7-7
Figure 7-5:	Geology Map, Doyon-Westwood Property	7-9
Figure 7-6:	Fayolle Property Geology Map	7-12
Figure 7-7:	Geological Map – Plan View of Level 132-00.....	7-16
Figure 7-8:	Westwood Deposit Central Cross-Section	7-17
Figure 7-9:	Key Structural Features, Westwood	7-19
Figure 7-10:	Cross-Section Showing Mineralization, Zone 2 Extension	7-22
Figure 7-11:	Cross-Section Showing Mineralization, North Corridor	7-23
Figure 7-12:	Cross-Section Showing Mineralization, Westwood Corridor	7-24
Figure 7-13:	Geology Map, Grand Duc Area	7-27
Figure 7-14:	Legend Key to Accompany Figure 7-13.....	7-28
Figure 7-15:	Mineralization Plan View, Grand Duc	7-30
Figure 7-16:	Mineralized Zones Longitudinal Section, Grand Duc	7-31
Figure 7-17:	Cross-Section, Mineralized Zones, Grand Duc.....	7-32
Figure 9-1:	Strip Sampling, 2010–2013.....	9-3
Figure 9-2:	Mobile Metal Ion Survey	9-5
Figure 9-3:	Ground Magnetometer Geophysical Surveys, Fayolle Property	9-7
Figure 9-4:	Ground IP Geophysical Surveys, Fayolle Property	9-8

Figure 9-5:	Prospective Areas, Doyon-Westwood Property	9-10
Figure 9-6:	Prospective Area, Westwood–Ellison	9-11
Figure 10-1:	Drill Collar Location Plan By Operator, Doyon–Westwood Property	10-9
Figure 10-2:	Drill Collar Location Plan By Location, Doyon–Westwood Property	10-10
Figure 10-3:	Drill Collar Location Plan, Fayolle Property	10-11
Figure 10-4:	Drill Collar and Trace Location for Drilling Supporting Mineral Resource Estimates, Westwood	10-12
Figure 10-5:	Typical Plan View Showing Drill Holes and Mineralized Zones used for the Current Mineral Resources Estimates, Westwood (elevation 3640; level 1320-00)	10-18
Figure 10-6:	Typical Cross Section Showing Drill Holes and Mineralized Zones used for the Current Mineral Resource Estimate, Westwood (easting 14,300)	10-19
Figure 11-1:	RC Grade Control Sampling	11-4
Figure 14-1:	Stereonet Representation, Structurally Controlled Mineralized Shoots Inside Schistosity Planes	14-2
Figure 14-2:	Example Capping Analysis, Group E	14-6
Figure 14-3:	Variography Study for Group F	14-9
Figure 14-4:	Metal-Grade Percentile Plot of WW28A Showing Cut-Off Thresholds	14-11
Figure 14-5:	Semi-Variogram Of Cut-Off #1 As An Example (WW28A)	14-12
Figure 14-6:	Comparison of the Mean Grades for Sample Data (A), MIK (B) and OK (C) for Mineralized Lens Z230A (rockcode 320)	14-18
Figure 14-7:	Comparison of Composite Gold Grades to Block Grades (MIK and OK interpolation) for Mineralized Lens Z230A (rock code 320)	14-19
Figure 14-8:	Model and Zone Location Map, Grand Duc	14-26
Figure 14-9:	Example Cross-Section Showing Confidence Categories, Grand Duc	14-31
Figure 14-10:	Westwood Mineral Resources Classification	14-35
Figure 15-1:	Westwood Mineral Reserve Classification, Including Indicated Mineral Resources Not Converted to Mineral Reserves	15-7
Figure 16-1:	Geotechnical Risk Management Flowsheet	16-6
Figure 16-2:	Westwood Seismic Events History	16-10
Figure 16-3:	Former Mining Method, Westwood	16-12
Figure 16-4:	Current Mining Method, Westwood	16-13
Figure 16-5:	Longitudinal Section, Mine Layout, Westwood	16-15

Figure 16-6:	Ventilation System Layout Schematic	16-18
Figure 16-7:	Backfill System Layout Schematic.....	16-20
Figure 16-8:	Final Pit Layout Plan, Grand Duc	16-26
Figure 17-1:	Grinding, Leaching, Adsorption and Stripping Circuit	17-2
Figure 17-2:	Cyanide Destruction and Paste Backfill Circuits.....	17-3
Figure 17-3:	Water and Tailings Management	17-4
Figure 18-1:	General Surface Infrastructure Westwood–Grand Duc	18-3
Figure 18-2:	Westwood Mine Infrastructure	18-4
Figure 18-3:	Doyon Area Surface Infrastructure – Plan View	18-5
Figure 18-4:	Grand Duc Surface Infrastructure – Plan View	18-6

1 SUMMARY

1.1 Introduction

Mr. Bernard Haley, P.Eng., Mr. Abderrazak Ladidi, P.Geo., Mr. Martin Perron, P.Eng., Mr. Louis Nkoy Manda Mbomba, P.Eng., Dr. Ali Jalbout, P.Eng. and Mr. Steve Pelletier, P.Eng., have prepared this technical report (the Report) on the Westwood Complex (or the Project) in Quebec, Canada for IAMGOLD Corporation (IAMGOLD).

IAMGOLD holds a 100% interest in the Project. The Project consists of two property areas, Doyon-Westwood and Fayolle. The Doyon-Westwood property includes the Westwood underground mine (Westwood), and Grand Duc open pit (Grand Duc), collectively the Westwood Complex. The Westwood mine has been in operation since 2014, when commercial production was declared, and Grand Duc since October, 2019. The Doyon-Westwood property area includes two former mining operations, Doyon and Mouska. Open pit operations at the Fayolle deposit commenced in February 2023 and the deposit was mined out in June 2024. The Fayolle open pit and associated infrastructure were being reclaimed at the Report effective date.

1.2 Key Outcomes

Key findings of this Report include:

- Proven and Probable Mineral Reserves:
 - Westwood: 2.6 Mt grading 11.45 g/t Au;
 - Grand Duc: 1.7 Mt grading 1.02 g/t Au;
- Westwood mine life from 2025–2032; Grand Duc mine life to 2025 with processing completed in 2027;
- Life-of-mine (LOM) capital cost estimate for Westwood of US\$260.7 million;
- Average LOM operating costs on a unit basis are US\$239.91/t milled, including US\$365.66/t milled at Westwood and US\$36.57/t at Grand Duc;
- Measured and Indicated Mineral Resources (inclusive of those Mineral Resources converted to Mineral Reserves):
 - Westwood: 3.97 Mt grading 12.80 g/t Au;

- Grand Duc: 3.01 Mt grading 1.25 g/t Au;
- Inferred Mineral Resources:
 - Westwood: 4.29 Mt grading 13.03 g/t Au;
 - Grand Duc: 0.08 Mt grading 1.28 g/t Au.

1.3 Terms of Reference

The Report was prepared to support disclosure of updated Mineral Resource and Mineral Reserve estimates and mine plans as announced on 5 December, 2024 in IAMGOLD's news release titled "IAMGOLD Provides Westwood Updated Mine Plan and Mineral Resource & Mineral Reserve Estimates".

Updated Mineral Resource and Mineral Reserve estimates and an updated life-of-mine plan are provided for Westwood and Grand Duc in this Report.

Units used in the report are metric units unless otherwise noted. Monetary units are in United States dollars (US\$) unless otherwise stated. The Report uses Canadian English.

Mineral Resources and Mineral Reserves are reported in accordance with the Canadian Institute of Mining, Metallurgy and Petroleum (CIM) Definition Standards for Mineral Resources and Mineral Reserves (May 2014; the 2014 CIM Definition Standards) and were prepared with reference to the CIM Estimation of Mineral Resources & Mineral Reserves Best Practice Guidelines (November, 2019; the 2019 CIM Estimation Guidelines).

1.4 Project Setting

The Westwood and Grand Duc deposits are located in the municipality of Preissac, Bousquet Township, approximately 40 km east of the town of Rouyn-Noranda and 80 km west of the town of Val d'Or. The Fayolle property is located in the Aiguebelle and Cléricy townships, approximately 35 km northeast of Rouyn-Noranda, Québec, and approximately 40 km northwest of the Westwood mine. There are previously operating mines in the Project area, the most significant of which were Doyon and Mouska situated 1.7 km and 4.8 km west of the Westwood mine, respectively.

The Westwood Complex is located on Arthur Doyon Road, 4 km east of the intersection of the Saint-Norbert-de-Mont-Brun Road and Arthur Doyon Road. The nearest railway line to the Westwood Complex is located <10 km to the south of the operations. The nearest active airport is the Rouyn-Noranda airport located about 25 km east of the Westwood Complex.

The Fayolle property area is accessible via Chemin de la Montagne from St-Norbert-de-Mont-Brun.

The regional climate varies from dry hot summers to cold snowy winters. Mining operations at Westwood and Grand Duc are conducted year-round. Heating is required in winter for the Westwood mine, and to keep ventilation infrastructures and ore bins free of ice. Exploration activities can be conducted year-round.

The Westwood Complex is located in glaciated terrain. The topography is relatively flat, with multiple permanent and intermittent creeks. The Westwood Complex area hosts mature forests, including spruce, pine, fir, larch, poplar, birch, and cedars.

Elevations within the Fayolle property range from 290–350 m above sea level. The northern property area has more topographic relief and consequently more outcrop. Two lakes, Matissard and Caste, are present in the eastern property area. A small creek, Ruisseau Paré, occurs in the deposit vicinity. Vegetation consists of a mixture of deciduous and coniferous trees, including ash, birch, spruce, poplar, aspen, pine, and fir.

1.5 Mineral Tenure, Surface Rights, Water Rights, Royalties and Agreements

The Project is wholly-owned by IAMGOLD.

The Doyon-Westwood property extends over about 8 km east–west by approximately 5 km north–south, and comprises 80 mineral titles, covering an area of 3,294.57 ha, of which five are mining leases (bail minier or BM), and 75 are map-designated cells (cellule désignée sur carte or CDC).

The Fayolle property consists of 42 mineral titles covering an area of 1,382.62 ha in Aiguebelle and Cléricy townships, of which one is a mining lease and the remaining 41 titles are map-designated cells.

Mining leases in Québec are initially valid for 20 years and may be extended for up to three additional periods of 10 years. However, it is possible to extend the mining lease for additional periods of five years after the third renewal. Except for the first period of validity which is of three years, the mineral claims are valid for periods of two years, to the extent that the holder meets the conditions provided for under the Mining Act. All claims are in good standing as at the Report effective date. IAMGOLD will renew claims as needed using the standard renewal process in Quebec.

IAMGOLD holds all of the relevant surface rights to support the LOM plan envisaged in this Report.

IAMGOLD holds all of the relevant water rights to support the LOM plan envisaged in this Report. IAMGOLD is actively evaluating water recycling and re-use options to reduce the operational reliance on surface waters.

The Doyon-Westwood property is not subject to any royalties or any other encumbrances. Globex Mining Enterprises Inc. (Globex) holds a 2% net smelter return (NSR) royalty on the mineral claims within the Fayolle property. IAMGOLD is in discussions relating to potential royalty payments to First Nations.

1.6 History

Prior to IAMGOLD's Project interest, numerous companies had conducted exploration in the Doyon-Westwood property area in the period 1910–2006, and in the Fayolle property area from 1946–2019. Work completed included prospecting, geological mapping, geochemical sampling, geophysical surveys, metallurgical testwork, surface and underground core drilling, mineral resource and mineral reserve estimates, engineering studies, and mining operations.

IAMGOLD obtained its interest in the Doyon-Westwood property in 2006 and in the Fayolle property in 2020. Work completed by IAMGOLD included metallurgical testwork, surface and underground core drilling, Mineral Resource and Mineral Reserve estimates, engineering studies, and mining operations. The Westwood mine has been in operation since 2014, when commercial production was declared, and Grand Duc since 2019. Operations at Fayolle ran from early 2023–mid-2024; the Fayolle deposit is mined out.

1.7 Geology and Mineralization

The deposits in the Project area are examples of greenstone-hosted orogenic gold deposits. The Westwood and Grand Duc deposits also include characteristics of gold-rich volcanic massive sulphide (VMS) deposits.

The Project is situated within the Southern Volcanic Zone of the Abitibi sub-province, part of the Archean Superior Province. The Abitibi Subprovince is divided into the Southern and Northern Volcanic Zones, which are separated by the Porcupine-Destor-Manneville Fault Zone. A second major fault system, the Cadillac-Larder Lake Fault Zone, separates the Southern Volcanic Zone from the sedimentary rocks of the Pontiac Terrane accretionary prism to the south.

Gold mineralization in the Southern Volcanic Zone forms major mineralized deposit clusters within mining districts. Such mining districts include the Doyon-Bousquet-LaRonde mining camp that hosts the Westwood and Grand Duc deposits.

The Southern Volcanic Zone consists of an Archean volcano-sedimentary assemblage divided into three volcanic groups and two sedimentary groups. Rocks have typically been metamorphosed to greenschist to sub-greenschist facies, with amphibolite facies in the vicinity of the intrusive plutons.

The Westwood deposit is approximately 1.9 km long by 500 m wide, generally trending east–west and dipping steeply south. Mineralization has an average thickness of 1.7 m. The deposit has been drill tested to an approximate 2.5 km depth. It remains open at depth and to the west. Mineralization in the Westwood area forms three easterly-trending, strongly deformed (D2 flattening and stretching), steeply south-dipping corridors that are stacked from north to south: the Zone 2 Extension, North, and Westwood Corridors. Mineralization styles include gold-bearing VMS-type lenses, quartz veins, and disseminated sulphide zones.

The Grand Duc deposit is about 620 m long in the east–west direction, by 300 m wide. Mineralization has an average thickness of 30 m. The deposit has been drill tested to 250 m depth. It remains open to the west and east. Mineralization at Grand Duc is associated with a miarolitic facies within trondhjemite. Gold mineralization occurs in veins, fracture fills, as disseminations, and in foliation-parallel pyrite bands.

1.8 Drilling and Sampling

As at 1 October, 2024, the total combined surface and underground core drilling in the Doyon, Grand Duc, Mouska, Westwood and Fayolle mining areas and surrounding tenures totals 29,400 drill holes for 3,959,041 m of drilling from surface and underground. Much of this total includes drill holes from former operations, where the mineralization is mined-out. Drill holes were completed for exploration, infill, Mineral Resource and Mineral Reserve estimation, geotechnical, hydrological, condemnation and metallurgical purposes.

Core sizes include NQ (47.6 mm core diameter), BQ (36.4 mm), and ATW (30.1 mm). The NQ-size is used at the beginning of a drill hole or for the entire drill hole to help control deviation. NQ-size is also used to increase the recovery if strongly sheared or fractured rock is expected. BQ is typically used for valuation and for some definition drilling work, while the ATW size is used only for shallow definition drilling (<50 m).

Core was typically washed and photographed prior to logging and sampling. Logging included recording lithology, alteration, sulphur content, texture, core recovery, structure, and veining. Geotechnical data, including core recovery, rock quality designation (RQD) and breakability, hardness, alteration, and schistosity intensities were recorded. A visual scale was used to describe the degree of alteration and foliation of the core.

After logging was completed, the core shack technicians (samplers) sawed the exploration core for sampling and sent half of the core for assaying. The whole core for definition and valuation samples was sent to the laboratory.

Surface collar coordinates are obtained in 3D using total station Leica TCRP1205, Leica MS60 or Leica TS15 instruments. Underground collar coordinates are obtained in 3D from total station Leica MS60, Leica TS15 or Leica TS16 instruments. Where known, down hole surveys were performed at nominal 50 m downhole intervals with Reflex or Flexit tools depending on the availability of the instrument. In some cases, readings were taken with a Pajari tool, or while other surveying instruments were away for maintenance. Some drill holes were surveyed with the Geophysic–INFINITEM method.

Prior to IAMGOLD's Project interest, and where known, samples from a mineralized zone were about 1 m in length, although some zones could be sampled on 0.5 m lengths to locate possible high grades along the vein being sampled. Outside of visually-mineralized areas, sample lengths typically ranged from 1–1.5 m. IAMGOLD samples varied in length, but were typically 1 m long in mineralization and 1–1.5 m long outside known mineralized zones.

Density measurements taken for the Westwood and Grand Duc deposits were performed by the immersion method. Densities range from 2.97 t/m³ in the Northern Corridor to 3.54 t/m³ for the sulphide lenses at Westwood. Densities at Grand Duc range from 2.68–2.7 t/m³.

Primary laboratories used included the Doyon mine laboratory, Accurassay Laboratories in Rouyn-Noranda, Québec, ALS Chemex in Val-d'Or, Québec, and Laboratoire Expert Inc. in Rouyn-Noranda. All laboratories other than the Doyon mine laboratory were independent. Laboratoire Expert was not accredited. The remaining laboratories held either ISO 9001, ISO14001, or ISO17025 accreditations. Check laboratories included ALS Chemex, Actlabs in Val-d'Or, and Techni-Lab S.G.B. Abitibi Inc located in Sainte-Germaine-Boulé, Québec. The laboratories were independent, and held ISO17025 accreditations. Production samples were analyzed at Laboratoire Expert and later MSALABS in Val d'Or, Québec. MSALABS is independent and holds ISO17025 accreditation.

Sample preparation varied over time and by laboratory. Crushing criteria included crushing to 70% passing 2 mm (10 mesh), 75% passing 10 mesh, 85% passing 10 mesh, and 90% passing 2 mm (10 mesh). Pulverization criteria included pulverizing to 85% passing 200 mesh, 85% passing 74 µm, and 95% passing 200 mesh. Analytical methods varied by laboratory. Fire assay was used for known, well-mineralized zones; all other samples were analysed using atomic absorption (AA). Typically, if the gold grade was >10 g/t Au, the sample was reassayed using a gravimetric method. On request, a multi-element analysis using inductively coupled plasma atomic emission spectroscopy or optical emission spectroscopy could be performed, providing a multi-element analytical suite.

Quality assurance and quality control (QA/QC) was used in all drill programs supporting estimation. This included submission of standard reference materials, blanks, and duplicate samples, and a program of

check assays. Review of the QA/QC data indicated no significant analytical biases and that assays were suitably precise.

Sample security measures typically included moving core samples from the drill site to the sample yards at the end of each drill shift and tracking sample shipments using industry-standard procedures.

1.9 Data Verification

Site visits were completed. The QPs individually reviewed the information in their areas of expertise, and concluded that the information supported Mineral Resource and Mineral Reserve estimation, and could be used in mine planning and in the economic analysis that supports the Mineral Reserve estimates.

1.10 Metallurgical Testwork

The process plant has been treating ore since the 1980s, and specifically treating ore from Westwood since 2013; as such the metallurgy is well understood.

Metallurgical testwork has been conducted by a number of independent laboratories and third-party consultants over the Project life. These include the laboratories SGS-Lakefield in Ontario, Laboratoire du CEGEP de l'Abitibi-Témiscaminque, COREM and the Unité de recherche et de service en technologie minérale in Quebec, and the Doyon mine laboratory and process plant. There is no international standard of accreditation provided for metallurgical testing laboratories or metallurgical testing techniques.

Work completed included chemical analysis (inductively-coupled plasma (ICP) optical emission spectroscopy, ICP mass spectrometry, whole rock analysis), mineralogy (QEMSCAN), comminution (Bond ball mill work index (BWi), Bond abrasion index (BAi), Miller number abrasivity tests), gravity recoverable gold tests, cyanide index tests, carbon-in-leach (CIL) tests, bulk sample testwork, cyanide destruction testwork, and acid base accounting (ABA) and net acid generation (NAG) testing.

The results of the metallurgical test programs indicate that the ore types tested from Westwood and Grand Duc are amenable to CIL methods. The process plant has reasonably consistently achieved gold recoveries of > 92%. In 2021, when lower head-grade material was treated, the recovery averaged 91.5%. The current life of mine (LOM) plan assumes an average gold recovery of 95% for Westwood, and 90% for Grand Duc.

There are no known deleterious elements in the LOM plan that would be expected to affect metallurgical recoverability or product saleability.

1.11 Mineral Resource Estimation

1.11.1 Westwood

The Mineral Resource estimate is based on 6,270 core drill holes (1,328,575.38 m) drilled from surface and underground between 1938–2024. This selection contains 476,368 sampled intervals taken from 600,323.71 m of drilled core. One block model was constructed for the entire Westwood deposit. The 3D wireframes of the mineralization lenses, the buffers, and the completed underground excavations (as at 30 April, 2024) act as sub-block triggers for their coding. The block model uses a parent block size of 4 x 1 x 4 m, sub-blocked to 1 x 0.5 x 1 m.

The mineralization model consists of 128 mineralized lenses grouped into three corridors designed without a minimum thickness (i.e., using the true thickness of the mineralized lenses) and are, therefore, not diluted. The mineralized lenses were modelled over the extent of the logged geological control(s) that are characteristic to each zone and snapped to assays, without a geological cut-off grade, in favour of geological continuity. For drill holes without descriptions, modelling was guided by the gold grades using a 2.0 g/t Au cut-off grade. These lenses were used as interpolation domains. A 10 m buffer was generated in Leapfrog around the mineralized lenses in each corridor, and these buffer zones were used as domains to interpolate dilution. The modelled Bousquet Fault truncates the mineralized lenses and buffers. IAMGOLD prepared and provided wireframes of underground excavations (as at 30 April, 2024). These were used to code the block models for the mined-out portions of mineralized lenses. Mined-out voids from May and September 2024 were mathematically removed from the Mineral Resource statement.

High-grade capping was performed on each group of veins separately, with caps applied to the raw assay data. The capped gold assays were composited to 1.0 m lengths. Compositing was applied to both capped and uncapped assays, as the multiple-indicator kriged (MIK) interpolation was carried out on uncapped composites and ordinary kriging (OK) interpolation used capped composites.

Density measurements were grouped according to the mineralized zones. The assumption that the mineralized material in each group shares similar characteristics, including density, is reasonable and consistent with the grade and tonnage estimation.

A variographic analysis of capped composites was performed for each corridor (CN, Westwood, and Zone 2 Ext) and the buffer zone to optimize the data for OK interpolation. The same variographic parameters were applied to all groups of mineralized lenses in a given corridor.

Historically, since the beginning of the underground operation at Westwood, the mine-to-mill reconciliation shows a regular negative 27% discrepancy on ounces of gold (overall 73%) between the estimated Mineral Resource and the mill, meaning the mill is steadily returning 27% more ounces than planned. It has been demonstrated that this discrepancy was caused by a sampling bias in the drill hole database. To mitigate this discrepancy, the geological interpretation was tightened to mineralized intervals only instead of a minimum mining width strategy, and MIK interpolation was preferred where reconciliation data were available.

The interpolation method was set to MIK in domains with a sufficient number of composites. Only lenses with sufficient data and historical mine-to-mill reconciliation were selected for the MIK modelling. None of the lenses in the North Corridor were considered, as no mine-to-mill reconciliation data were available for this corridor. Ten to 12 thresholds were determined for each vein to create indicator variables and generate a probability distribution for each estimation node. The expected value from this probability distribution was used as the MIK result.

Each domain (mineralized lens or buffer) was estimated independently as a hard boundary using the capped composite gold grades for OK interpolation and the uncapped composites for MIK interpolation. MIK interpolation was completed for each threshold determined within a specific grade distribution. For all unique blocks within a mineralized lens domain, OK interpolation was applied to all the independent threshold subset data using the results of each individual variography study. A grade was then estimated for each threshold using composites spatially associated with the block. The final estimated grade for each unique block is a summation of individual threshold OK results weighted by the frequency of occurrence of these thresholds in the cumulative frequency plot of the mineralized lens dataset. The advantage of this interpolation technique was that the metal factor associated with each threshold can be adjusted to correct for mine-to-mill discrepancies to address the sampling bias. This was achieved by adjusting the upper tail distribution of the higher grades.

The OK variography study provided the parameters for interpolating the grade model using point datasets corresponding to the mid-points of composited intervals. A three-pass strategy was used. The remaining high gold values, constrained by the dilution buffers, used a restricted search to reduce the smearing of high values (>1 g/t Au) over large distances.

Visual and statistical validation was performed on the estimates. No material biases were identified from the validation checks.

Confidence classifications were assigned based on a consideration of geological and grade continuity, drill hole spacing and interpolation pass. The Measured category was assigned to blocks estimated with a minimum of two drill holes in areas where the distance from a drill hole was <15 m and within 10 m of

an underground opening in a mineralized zone. The Indicated category was assigned to blocks estimated with a minimum of two drill holes in areas where the distance from a drill hole was <15 m. The Inferred category was assigned to blocks estimated in areas where the distance from a drill hole was <75 m.

Constraining volumes were produced using Deswik Stope Optimizer (DSO) software with a minimum mining shape of 13 m along the strike of the deposit, a height of 25 m and a minimal width of 2.4 m. The DSO results were used to constrain the Mineral Resource estimate.

The Mineral Resource estimate is reported at a cut-off grade of 5.7 g/t Au for both the MIK and the OK methods.

1.11.2 Grand Duc

Mineral Resource estimation is based on 650 core holes (104,799 m drilled) and 64,491 assays. Whole block cells have dimensions of 5 m long (X-axis) x 5 m wide (Y-axis) x 10 m vertical (Z-axis). No sub-cells were applied to the model.

Three models were constructed, an economic model, a lithological model, and a structural model. The economic model was used for interpolation, and consists of north–south-trending high-grade veins, low-grade envelopes, high-grade zones, and a dilution solid. A minimum thickness of 1 m was used to model the north–south veins, and a buffer of 5 m was applied to the wireframes for grade interpolation purposes.

Caps were applied to raw assay values prior to compositing. A three-step capping process was used on composites during estimation to limit unreasonable estimation of very high-grade composites. The first interpolation pass used composites where the highest capping value was applied, and subsequent passes used lower capping limits on composites with limited volume influence.

All drill hole intervals were composited to 1.5 m intervals inside the mineralized zones.

Fixed density values were applied in the block model, and were based on the lithological model.

Three-dimensional directional variography was performed on the 1.5 m capped composites for all of the estimation domains. The ellipsoids used in estimation were based on the variogram results.

Ordinary kriging was used for estimating the grade in each domain. Validation models using inverse distance weighting to the third power (ID3) and nearest-neighbour methods were completed. The grade interpolation was a three-pass process, increasing search ranges between passes, and varying the minimum number of composites.

No Measured Mineral Resources were classified other than in stockpiles. Indicated Mineral Resource classification required at least three drill holes within a 30 m radius. Inferred Mineral Resource classification required at least three drill holes within a 50 m radius.

Model validation included swath plots, comparison with previous models, and comparison with reconciliation data. No material biases were identified.

Mineral Resource were constrained within a pit shell to meet reasonable prospects of eventual economic extraction criteria.

The stockpile tonnage estimate is based on Wenco truck counts that are reconciled on a monthly basis with drone surveys of the stockpiles. Grade is assigned to the stockpiles from the grades of the material mined from the short-term grade model.

1.12 Mineral Resource Statement

Mineral Resources are reported with an effective date of 30 September, 2024, using the Mineral Resource definitions set out in the 2014 CIM Definition Standards, and are reported in situ, inclusive of those Mineral Resources converted to Mineral Reserves. Mineral Resources that are not Mineral Reserves do not have demonstrated economic viability.

Measured, Indicated and Inferred Mineral Resources estimated for the Westwood deposit, are provided in Table 1-1. The Qualified Person for the estimate, excepting stockpiles, is Mr. Martin Perron, P.Eng., of Norda Stelo Inc. Measured Mineral Resources in stockpiles are provided in Table 1-1. The Qualified Person for the stockpile estimate for Westwood is Mr. Louis Nkoy Manda Mbomba, P.Eng., an IAMGOLD employee. A section showing the location of the Mineral Resources at Westwood is provided in Figure 1-1.

The decrease in Measured and Indicated Mineral Resources estimated for the Westwood Mine from the last technical report is primarily due to tighter confidence criteria applied to the mine planning process. To reduce variations in mine planning, Indicated Mineral Resources were classified based on the completed definition drill pattern requirements. The changes to the Indicated Mineral Resources classification requirements were primarily responsible for the increase in Inferred Mineral Resources; the other key factor contributing to increases in Inferred Mineral Resources was identification of additional mineralization through exploration drilling.

Table 1-1: Mineral Resource Statement, Westwood

Class	Tonnes	Gold Grade (g/t Au)	Contained Ounces
Measured	777,000	13.09	327,000
Measured (Stockpiles)	4,000	8.64	1,200
Indicated	3,190,000	12.74	1,306,700
Measured + Indicated	3,971,000	12.80	1,634,900
Inferred	4,289,000	13.03	1,797,400

Notes to accompany Westwood Mineral Resource Table

1. The effective date of the Mineral Resource estimate is 30 September, 2024.
2. The Qualified Person for the estimate excepting stockpiles is Martin Perron, P.Eng., from Norda Stelo Inc. The Qualified Person for the stockpile estimate is Mr. Louis Nkoy Manda Mbomba, P.Eng., an IAMGOLD employee.
3. Mineral Resources are reported inclusive of Mineral Reserves. Mineral Resources that are not converted to Mineral Reserves do not have demonstrated economic viability.
4. The estimate encompasses 128 mineralized lenses in three zones (Corridor North, Westwood, and Zone 2 Extension) using the grade of the adjacent material when assayed or a value of zero when not assayed. Three dilution buffer zones encompassing all mineralized zones (one for each zone) were created to better reflect the internal dilution within the constraining shapes.
5. High-grade capping supported by statistical analysis was done on raw assay data before compositing. It was established on a zone-by-zone basis, varying from 75–500 g/t Au for mineralized zones and 10–20 g/t Au for the dilution buffer zones. Composites (1.0 m) were calculated within the zones using the grade of the adjacent material when assayed or a value of zero when not assayed.
6. The estimate was completed using a sub-block model in Isatis.neo 2024.04. The parent block size was 4 x 1 x 4 m (subblocks of 1 x 0.5 x 1 m).
7. Grade interpolation was obtained by multiple-indicator kriging for 13 lenses and ordinary kriging for all remaining lenses and buffers using hard boundaries.
8. Density values were assigned by lens group. Densities of 2.9, 3.7, 3.1, 3.0, 3.0 and 3.1 g/cm³ were assigned to groups A, B, C, E, F and G, respectively. A value of 2.8 g/cm³ was assigned to the Corridor North buffer, 2.9 g/cm³ to the Westwood buffer and 2.9 g/cm³ to the Zone 2 Extension buffer.
9. The mineral resource estimate is classified as Measured, Indicated, and Inferred. The Inferred Mineral Resource category is defined with a minimum of two drill holes in areas where the drill spacing is <75 m, and reasonable geological and grade continuity have been demonstrated. The Indicated Mineral Resource category is defined with a minimum of two drill holes in areas where the drill spacing is <15 m, and reasonable geological and grade continuity have been demonstrated. Measured Mineral Resources were classified when Indicated Mineral Resources are present

within 10 m of an underground opening within a mineralized zone. The initial resource classification was edited with a mix of automated and manual methods to eliminate isolated blocks of one confidence category, considering the spatial continuity of drill holes, and was run in each mineralized solid to upgrade inferred blocks, or downgrade indicated blocks locally, as needed. The measured resources from the original classification were checked and confirmed with the mining development data. The Measured Mineral Resources from the original classification were not smoothed to prevent downgrading the classification.

10. The Mineral Resource estimate is locally constrained within Deswik Stope Optimizer shapes using a minimal mining width of 2.4 m for long hole stoping. It is reported at a cut-off grade of 5.7 g/t Au. The following parameters were used: mining cost = \$200.16/t; processing cost = \$24.65/t; G&A = \$41.11/t; sustaining capital cost = \$80.22/t; refining costs = \$4.56/oz; gold price = US\$1,800.00/oz; US\$/C\$ exchange rate = 1.25; and process recovery = 95.0%. The cut-off grades should be re-evaluated in light of future prevailing market conditions (metal prices, exchange rates, mining costs etc.).
11. The number of metric tonnes was rounded to the nearest thousand, as required by Form 43-101F1, and any discrepancies in the totals are due to rounding effects. The metal contents are presented in troy ounces (tonnes x grade / 31.10348) rounded to the nearest hundred. Numbers may not add up due to rounding.
12. The Qualified Person is not aware of any known environmental, permitting, legal, political, title-related, taxation, socio-political, or marketing issues that could materially affect the Mineral Resource estimate.

Figure 1-1: Westwood Mineral Resources Classification

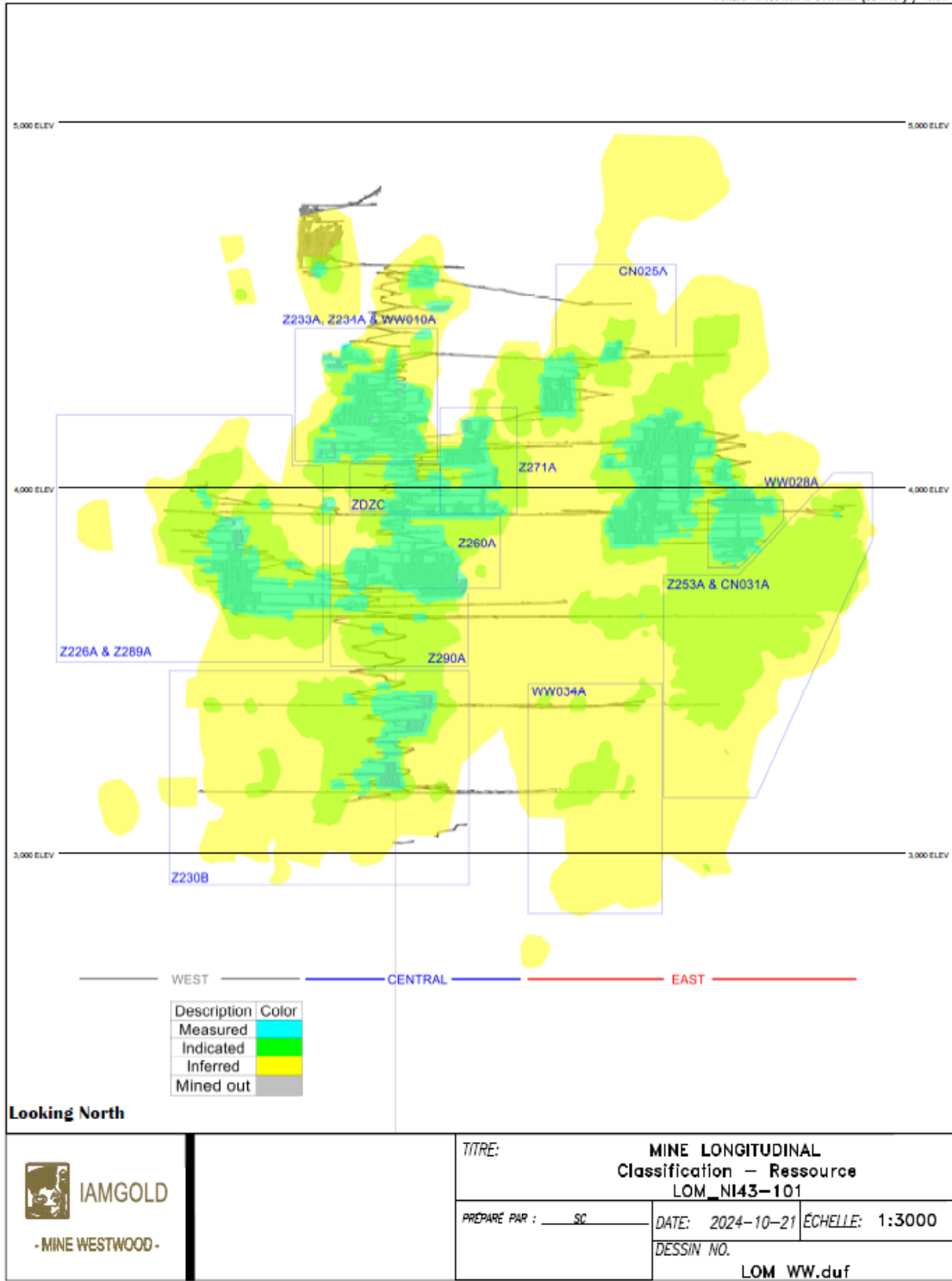

Measured, Indicated and Inferred Mineral Resources estimated for the Grand Duc deposit, are provided in Table 1-2. The Qualified Person for the estimate is Mr. Abderrazak Ladidi, P.Geo., an IAMGOLD employee.

The combined Measured, Indicated and Inferred Mineral Resources estimated for Westwood and Grand Duc are included in Table 1-3. This table is not additive to Table 1-1 and Table 1-2.

Areas of uncertainty that may materially impact the Mineral Resource estimates include: changes to long-term gold price assumptions; changes in local interpretations of mineralisation geometry and continuity of mineralised zones; changes to geological shape and continuity assumptions; changes to metallurgical recovery assumptions; changes to the operating cut-off assumptions for assumed long hole mining operations at Westwood; changes to the inputs to the constraining pit shell used for Grand Duc; changes to the input assumptions used to derive the conceptual underground outlines used to constrain the Westwood estimate; changes to the cut-off grades used to constrain the Westwood estimate; changes to the cut-off grade used to report the Grand Duc estimate; variations in geotechnical, hydrogeological, and mining assumptions; changes to environmental, permitting and social license assumptions; and changes to legal, political, title-related, taxation, socio-political, or marketing assumptions.

Table 1-2: Mineral Resource Statement, Grand Duc

Class	Tonnes	Gold Grade (g/t Au)	Contained Ounces
Measured (stockpiles)	268,000	0.64	5,500
Indicated	2,740,000	1.31	115,600
<i>Measured + Indicated</i>	<i>3,008,000</i>	<i>1.25</i>	<i>121,000</i>
Inferred	80,000	1.28	3,300

Notes to accompany Grand Duc Mineral Resource Table:

1. Mineral Resources are reported at an effective date of 30 September, 2024. The Qualified Person for the estimate is Mr. Abderrazak Ladidi, P.Ge. an IAMGOLD employee.
2. Measured Mineral Resources are reported in place as stockpiles. Indicated and Inferred Mineral Resources are insitu.
3. Mineral Resources are reported inclusive of Mineral Reserves. Mineral Resources that are not converted to Mineral Reserves do not have demonstrated economic viability
4. Mineral Resources are reported using the 2014 CIM Definition Standards.
5. Mineral Resources are reported assuming a gold price of US\$1,800 and a US\$:C\$ exchange rate of 1.25. Mineral Resources are constrained within an optimized open pit shell, which use input assumptions including: mining costs of \$12.71/t mineralization and variable waste costs ranging from \$4.07–\$5.71, process costs of \$19.29/t and metallurgical recoveries that average 92%. Mineral Resources that are not in stockpiles are reported at a cut-off of 0.54 g/t Au. Mineral Resources in stockpiles have variable cut-offs, depending on the stockpile, which range from 0.54–0.9 g/t Au.
6. The number of metric tonnes was rounded to the nearest thousand and any discrepancies in the totals are due to rounding effects. The metal contents are presented in troy ounces (tonnes x grade / 31.10348) rounded to the nearest hundred. Numbers may not add up due to rounding.

Table 1-3: Mineral Resource Statement, Westwood and Grand Duc

Class	Tonnes	Gold Grade (g/t Au)	Contained Ounces
Measured (Stockpiles)	272,000	0.76	6,700
Measured	777,000	13.09	327,000
Indicated	5,930,000	7.46	1,422,300
<i>Measured + Indicated</i>	<i>6,979,000</i>	<i>7.83</i>	<i>1,756,000</i>
Inferred	4,369,000	12.82	1,800,700

Notes to accompany Westwood and Grand Duc Mineral Resource Table:

1. Mineral Resources are reported at an effective date of 30 September, 2024.
2. The Qualified Person for the Westwood estimate excepting stockpiles is Martin Perron, P.Eng., from Norda Stelo Inc. The Qualified Person for the Westwood stockpile estimate is Mr. Louis Nkoy Manda Mbomba, P.Eng., an IAMGOLD employee. The Qualified Person for the Grand Duc estimate is Mr. Abderrazak Ladidi, P.Geo. an IAMGOLD employee.
3. Other than stockpiles, Measured and Indicated and Inferred Mineral Resources are insitu.
4. Mineral Resources are reported inclusive of Mineral Reserves. Mineral Resources that are not converted to Mineral Reserves do not have demonstrated economic viability
5. Mineral Resources are reported using the 2014 CIM Definition Standards.
6. Footnotes detailing the key parameters and assumptions for the Mineral Resource estimate for Westwood accompanying Table 1-1 and footnotes detailing the key parameters and assumptions for the Mineral Resource estimate for Grand Duc accompanying Table 1-2 are also applicable to this table.
7. The number of metric tonnes was rounded to the nearest thousand and any discrepancies in the totals are due to rounding effects. The metal contents are presented in troy ounces (tonnes x grade / 31.10348) rounded to the nearest hundred. Numbers may not add up due to rounding.
8. This table is not additive to Table 1-1 and Table 1-2.

1.13 Mineral Reserve Estimation

Proven and Probable Mineral Reserves are reported for the Westwood and Grand Duc deposits and have been converted from Indicated and Measured Mineral Resources, respectively.

Mine designs supporting the Mineral Reserves were based on the operating life-of-mine plans assuming underground (Westwood) and open pit (Grand Duc) mining methods.

Inferred Mineral Resources within the mine designs (DSO) were treated as internal dilution and assigned a grade of 0.5 g/t Au, and the LOM plan is only based on Measured and Indicated Mineral Resources.

1.13.1 Westwood

The throughput rate assumption of 960 t/d is based on a detailed LOM plan that includes consideration of current and planned mining methods, geotechnical constraints and risks, materials handling system, mining equipment fleet, labour, infrastructure such as power supply, dewatering, backfilling, and ventilation. The mine plan assumes long-hole stoping methods with paste fill.

The operations use a break-even cut-off grade for Mineral Reserve reporting, based on the formula:

- Break-even cut-off grade = costs/revenue = (mining cost + processing cost + general & administrative cost + sustaining cost)/(metal price – transport and refining cost – royalties) x process recovery.

The break-even cut-off grade is 7.58 g/t Au, reducing to 6.82 g/t Au when the mine call factor is applied.

Reconciliation has shown that the average grade reported to the mill is higher than the stope grade estimate. A mine call factor is added to the cut-off grade to adjust the grade in the stopes to better align with the mill grade. This results in a reduction of 10% (approximately 1.03 g/t Au) in the cut-off grade for the Mineral Reserve estimates.

The historic external mining dilution is estimated at 63% for Mineral Reserves, with an associated grade of 0.5 g/t Au. This factor is applied to the stope shapes only.

1.13.2 Grand Duc

Open pit mining operations commenced in 2019 at Grand Duc, providing historical data on the geological setting, mining method, mining conditions, mining recoveries and dilution, production capacity, and mining costs. These historical data are used in the Mineral Reserve estimation process.

Input costs into pit optimization are based on historical costs and current open pit mining contractor costs. Costs include allowances for general and administrative (G&A), primary crusher, processing, and environmental costs.

The operations use a break-even cut-off grade for Mineral Reserve reporting, based on the formula:

- Break-even cut-off grade = costs/revenue = (mining cost + processing cost + general & administrative cost + sustaining cost)/ (metal price – transport and refining cost – royalties) x process recovery.

The break-even cut-off grade is 0.54 g/t Au; however, production uses different cut-off grades to segregate material and prioritize materials to haul to the mill.

The dilution assumption is 10% in the pit design and Mineral Reserve estimate, based on historical data. No mining recovery is applied.

1.14 Mineral Reserve Statement

Mineral Reserves are reported with an effective date of 30 September 2024 using the Mineral Reserve definitions set out in the 2014 CIM Definition Standards, and are reported at the point of delivery to the process plant. The Qualified Person for the estimates is Mr. Louis Nkoy Manda Mbomba, P.Eng., an IAMGOLD employee.

Mineral Reserves estimated for Westwood are provided in Table 1-4. A section showing the location of the Mineral Reserves is included as Figure 1-2. Mineral Reserves estimated for Grand Duc are provided in Table 1-5. The combined Mineral Reserves for Westwood and Grand Duc are summarized in Table 1-6. This table is not additive to Table 1-4 and Table 1-5.

There are a number of factors that may affect the Mineral Reserve estimate. The gold price influences Mineral Reserves, and its increase or decrease significantly impacts the cut-off grade and forecast cashflow outcomes. Geotechnical constraints must be rigorously respected in mining sequences. At the same time, the implementation of the Westwood algorithm allows all zones to be opened, which increases Mineral Reserves. Seismicity always represents a risk, but geotechnical strategies and tactics reduce this risk and allow for safe mining. Mining recovery and dilution are factors that directly influence the Mineral Reserves estimates. Even small changes in dilution can affect mining recoveries, and hence the ounces in the material delivered to the process plant. The mining cost factor influences the cut-off grade and the Mineral Reserve estimates. Process recovery is an element that impacts Mineral Reserves estimate, and maintaining LOM process recoveries at around 95% will represent a challenge. This challenge is being mitigated by the proposed capital investment plan.

Table 1-4: Mineral Reserves Statement, Westwood

Confidence Category	Tonnage	Gold Grade (g/t Au)	Contained Ounces
Proven	721,000	12.60	292,000
Probable	1,870,000	11.02	662,200
Stockpiles (Proven)	4,000	8.64	1,200
Total Proven + Probable	2,595,000	11.45	955,400

Notes to Accompany Westwood Mineral Reserves Table:

1. Mineral Reserves are reported at the point of delivery to the process plant with an effective date of 30 September, 2024. The Qualified Person for the estimate is Mr. Louis Nkoy Manda Mbomba, P.Eng., an IAMGOLD employee.
2. Mineral Reserves are reported using the 2014 CIM Definition Standards.
3. Mineral Reserves are reported using a gold price of US\$1,500/oz Au and assume a C\$:US\$ exchange rate of 1.25. Mineral Reserves are constrained within mineable shapes, that use input assumptions including long-hole open stope mining methods, mining costs of \$200.16/t, process costs of \$24.65/t, general and administrative costs of \$41.11/t, Sustaining capital cost of \$80.22/t, gold treatment and refining costs of \$4.56/t, minimum mining width of 2.4 m, dilution assumption of 63% at 0.5 g/t Au, mining recovery of 85%, and metallurgical recoveries averaging 95%. Mineral Reserves are reported at a 6.82 g/t Au cut-off, which is inclusive of a 10% mine call factor.
4. Table numbers have been rounded. Totals may not sum due to rounding.

Figure 1-2: Westwood Mineral Reserve Classification, Including Indicated Mineral Resources Not Converted to Mineral Reserves

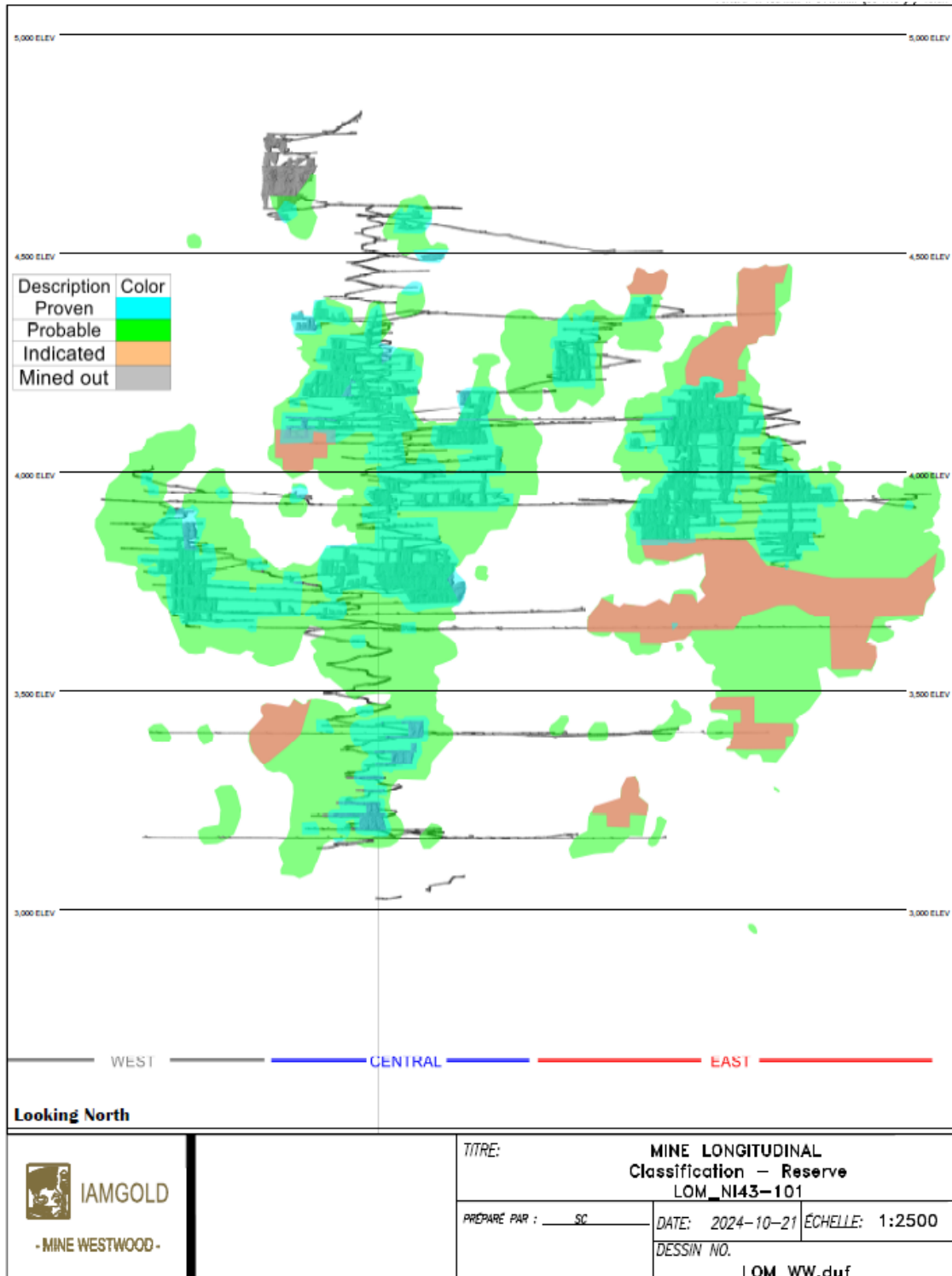

Table 1-5: Mineral Reserves Statement, Grand Duc

Confidence Category	Tonnage	Gold Grade (g/t Au)	Contained Ounces
Proven	—	—	—
Probable	1,445,000	1.09	50,900
Stockpiles (Proven)	268,000	0.64	5,500
Total Proven + Probable	1,713,000	1.02	56,300

Notes to Accompany Grand Duc Mineral Reserves Table:

1. Mineral Reserves are reported at the point of delivery to the process plant with an effective date of 30 September, 2024. The Qualified Person for the estimate is Mr. Louis Nkoy Manda Mbomba, P.Eng., an IAMGOLD employee.
2. Mineral Reserves are reported using the 2014 CIM Definition Standards.
3. Mineral Reserves are reported using a gold price of US\$1,800/oz Au and assume a US\$:C\$ exchange rate of 1.25. Mineral Reserves are constrained within an optimized open pit shell, which use input assumptions including: mining costs of \$12.71/t of ore and variable waste costs ranging from \$4.07–5.71/t, process costs of \$19.29/t, 10% dilution, bench face angles that range from 70° (north)–75°(south), and metallurgical recoveries that average 92%. Mineral Reserves are reported at a cut-off of 0.54 g/t Au.
4. Table numbers have been rounded. Totals may not sum due to rounding.

Table 1-6: Mineral Reserves Statement, Westwood and Grand Duc

Confidence Category	Tonnage	Gold Grade (g/t Au)	Contained Ounces
Proven	721,000	12.60	292,000
Probable	3,315,000	6.69	713,000
Stockpiles (Proven)	272,000	0.76	6,700
Total Proven + Probable	4,308,000	7.30	1,011,700

Notes to Accompany Westwood and Grand Duc Mineral Reserves Table:

1. Mineral Reserves are reported at the point of delivery to the process plant with an effective date of 30 September, 2024. The Qualified Person for the estimate is Louis Nkoy Manda Mbomba, P.Eng., an IAMGOLD employee.
2. Mineral Reserves are reported using the 2014 CIM Definition Standards.
3. Footnotes detailing the key parameters and assumptions for the Mineral Reserve estimate for Westwood accompanying Table 1-4 and footnotes detailing the key parameters and assumptions for the Mineral Reserve estimate for Grand Duc accompanying Table 1-5 are also applicable to this table.
4. Table numbers have been rounded. Totals may not sum due to rounding.
5. This table is not additive to Table 1-4 and Table 1-5.

1.15 Mining Methods

1.15.1 Westwood

The mine plan assumes long-hole open stoping methods and conventional underground equipment. The mine is Owner-operated.

Seismicity, as well as more variability in the rock mass and less continuity in strike of ore lenses than predicted, have all resulted in changes to the mining plan over the duration of operations. An extensive seismic risk analysis was performed in 2021 following significant seismic events in October 2020.

In-depth geotechnical analyses were performed by mine staff and external consultants to identify risks associated with mining sequence, infrastructure location, and support requirements. These included evaluations of stress state and rock mass classifications as well as a review of the seismic history.

Significant anisotropy also complicates the mine design, as certain rock type may be stable when perpendicular to the regional schistosity and unstable or prone to convergence when parallel to the schistosity. Even in the same rock type, different support patterns may be required.

These factors significantly increase the complexity of mine design, require additional resources, and increase risk.

Following the application of the different mitigation plans, however, the mine has experienced important drop of the seismic events shown in Figure 1-3.

Key items to note from that figure include:

- The seismic activity rate appears to have been reduced by half, which represents a significant decrease;
- This reduction is mainly attributed to changes in mining practices including:
 - Mining sequencing;
 - The extraction rate;
 - Mine planning based on the seismic potential of different areas (implementation of the geo-seismic strategy).

Figure 1-3: Westwood Seismic Events History

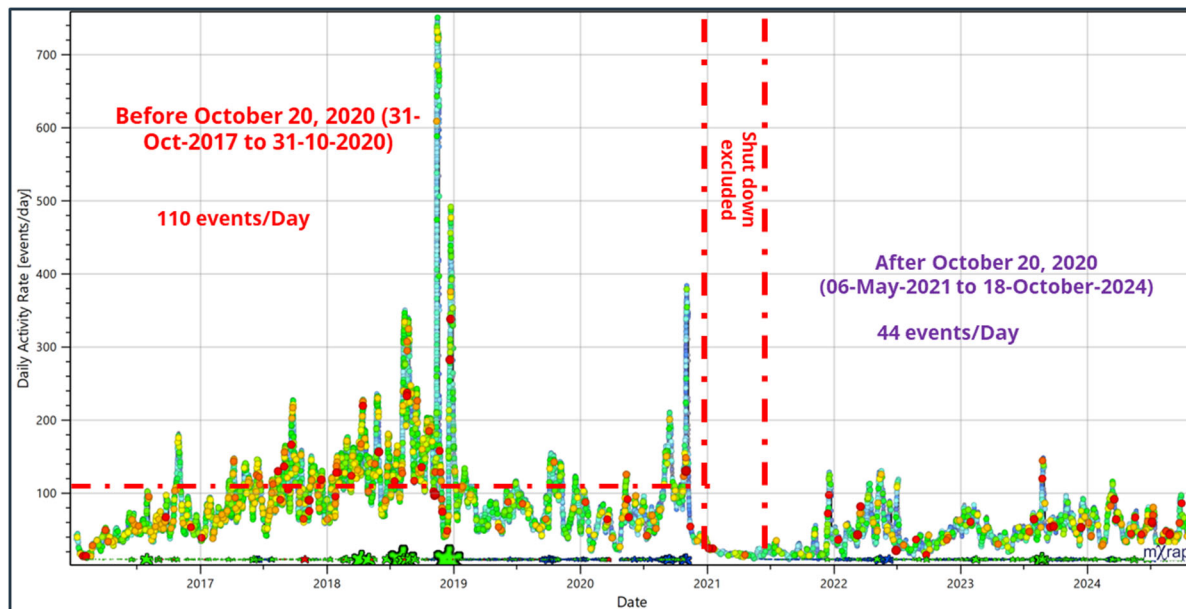

Note: Figure prepared by IAMGOLD, 2024

The general ground control approach is based on an array of mitigating measures that address a range of topics. Individual control measures all have uncertainty and limitations, and it is therefore preferable to meld numerous procedures together to build a robust management of risk, such that the approach is multi-faceted and does not rely on a single method or tool. Importantly, this multi-pronged approach is also a dynamic process: the inputs can evolve (by adding, eliminating, and/or combining criteria), the criteria and weighting associated with each can be adjusted as more data are collected and back-analyses are completed.

Stope dimensions are limited by expected dilution while development configurations are limited by the induced stress state and other components of seismic hazard. Mining methods will continue to be refined as mining experience is obtained. Ground support patterns as well as dilution and recovery rates are included in the mining plan according to current and expected performance, and will be updated as required.

Geotechnical considerations will continue to have a significant impact on the production plan of the Westwood Mine. The identified geotechnical risks at Westwood mine are as follows:

- Large seismic events causing rock ejection, and ground falls associated with seismic vibrations;
- Small seismic strain bursts, causing rock ejections.

The above risks could result in injuries, loss of infrastructure, equipment damage, or complete closure of mining openings if the seismic algorithm is not applied properly.

Water ingress is managed using a combination of sumps, pumps and drain holes to drain water to the main pumping system, which then pumps the water to the surface for water treatment.

The majority of the stopes will be mined in a bottom-up pillarless manner for better stress management; in areas already developed or above Level 1040, the mining method will remain a bottom-up pillarless or primary-secondary long-hole open stoping mining method. The transition from the primary-secondary method to a pillarless method is the result of a geotechnical study conducted after the major seismic event on October 30th, 2020, which recommended using a pillarless approach with a sequence designed, generally, to move stresses away from the mining front unidirectionally. The mining strategy is to mine the East, Central and Western sections of the mine simultaneously with as many as six mining areas mined concurrently to minimize production risk should one section be impacted by seismicity for a prolonged period of time. Consideration has been applied in the LOM to mitigate colliding mining fronts, as they create diminishing pillars that are detrimental to mine stability.

The mine is accessed via the Westwood shaft or the Warrenmac ramp. Main levels (shaft access) are spaced approximately 240 m apart; the majority of underground infrastructure, including maintenance facilities, warehouses and stockrooms, and electrical stations, are located on these levels. Sub-levels used for mining are spaced at about 25–30 m. A series of ore and waste passes are placed throughout the mine. The material handling plan varies by corridor. All underground material mined (ore + waste) must be hoisted to the surface, and the overall hoisting capacity depends on the loading pockets used. The LOM plan assumes a hoisting rate of 3,000 t/d. Once on surface, the ore is transported 2.5 km with 30 t haul trucks to the Doyon process plant.

Ventilation is a push–pull system. The permanent ventilation system provides fresh air via the production shaft and an intake raise connected to the surface. Exhaust air exits through a raise network leading to the surface and the main ramp portal.

A backfill plant is located next to the Westwood Shaft. Two backfill lines are connected to the underground backfill network. The primary backfill material is cemented backfill, generated from a mixture of tailings slurries and cement. Uncemented rockfill is occasionally used for filling the last stopes in a mining sequence.

The mine life based on Mineral Reserves for the Westwood Complex is forecast from 2025–2032.

The LOM plan provides for an overall production from Westwood, Grand Duc, and stockpiles of 4.0 Mt grading 7.51 g/t Au for 0.98 Moz Au.

1.15.2 Grand Duc

Mining is carried out using a conventional drill, blast, load, and haul surface mining method with a contractor-operated fleet. Equipment is conventional for open pit operations.

Pit slope parameters were designed by IAMGOLD staff and a third-party contractor, Entech Pty Ltd. A variety of monitoring techniques are implemented to monitor and manage slope stability and monitor the performance of the design.

The open pit is designed to reach a total depth of 110 m, and will be about 309 m long. Benches are designed on 10 m heights in overburden and 20 m heights in fresh rock. Berm widths are 20 m in overburden and 10 m in fresh rock. Ramps and roadways are typically 20 m wide, reducing to single-lane, 12 m, widths at the base of the pit.

Overburden material is disposed near the Grand Duc open pit. Waste is disposed in the Doyon North waste rock storage facility (WRSF).

The Grand Duc operations share a portion of the infrastructure required for the mining operations with Westwood, including the Doyon process plant, waste rock storage facility, and tailings storage.

The remaining mine life is to 2025, with processing continuing into 2027.

1.16 Recovery Methods

The metallurgical testing completed supports the process design criteria and the Doyon mill flowsheet.

The process plant was originally constructed in the 1970s and last refurbished in 2013 to increase throughput to 1.0 Mt/a. Upgrades were made to the grinding, cyanidation, strip, and tailings cyanide destruction circuits. A new paste backfill plant was also built to meet the Westwood Complex operational needs.

The plant has been operated both continuously, and in batch mode, since 2013, depending on ore availability. Currently, operations are 24 hours a day, seven days a week, 52 weeks a year. However, there will be portions of the current mine plan which will see reduced ore availability, and the plan is to have the plant operate in batch mode. Depending on the period, this may result in selected weeks in a month operations, or 3–4 days in a week operation.

There have also been instances over the plant history where the process plant toll-treated custom material from other mining operations. This remains an option since the process flowsheet is flexible and can accommodate third-party custom materials outside the LOM plan.

The Doyon plant treats ore via a conventional cyanidation process. Run-of-mine (ROM) ore is processed using a conventional single stage primary crusher followed by a two-stage semi-autogenous grinding (SAG) mill and ball mill grinding circuit, gravity circuit, pre-leach, carbon in leach (CIL) and carbon in pulp (CIP) circuits, in addition to associated gold recovery and carbon handling circuits to produce gold/silver doré.

The process flow sheet consists of the following:

- Crushing;
- Grinding;
- Gravity concentration and intensive cyanidation;
- Cyanide leaching of gravity tailings;
- CIL, CIP;
- Cyanide destruction;
- Tailings disposal;
- Acid wash and elution;
- Electrowinning and gold room;
- Carbon regeneration;
- Reagents make-up and distribution;
- Air services and plant water service.

Process consumables consist of reagents and grinding media.

Power is provided through the electrical network on site and supplied by Hydro-Québec. Annual power consumption for the process plant averages about 35–36 kWh/t (including operation of the paste backfill plant).

The plant requires about 1.1 Mm³ of process water annually. While process water can be drawn from the Bousquet River when necessary, most water is reclaimed from the TSF and/or the Doyon reclamation water management system so as to minimize water pumping from the river.

1.17 Project Infrastructure

Infrastructure required to support operations is in place. The main onsite infrastructure at Westwood and Grand Duc includes:

- Westwood underground mine: production shaft, Warrenmac ramp portal, hoist room, headframe; compressors water management systems;
- Grand Duc open pit mine;
- Doyon process plant;
- Mine services building: includes provision for general management, health, and safety, mine rescue, human resources, training, IT, technical services, environmental, mine operations personnel, dry facilities;
- Ventilation shaft and primary fans;
- Backfill plant;
- Waste stockpiles;
- Doyon in-pit tailings storage;
- Fuel bays and fuel storage;
- Main access road;
- Power supply (120 kV power line from Hydro-Québec);
- Natural gas line with gas supply by Énergir;
- Water systems (potable and domestic water supply, fire protection system, sewage disposal system);
- Tailings ponds;
- Effluent water treatment system.

The mine sites are drive-in, drive-out, with employees living in surrounding communities.

Process water for the Westwood Complex and the Doyon process plant is supplied by reclaim water and water from the Bousquet River. All water collected in the Westwood and Grand Duc areas is pumped to the water management system and treated in a high density sludge plant prior to discharge to the Bousquet River.

Electricity is supplied to the Westwood and Grand Duc mines via a 120 kV power line (Hydro-Québec), and is stepped down to 25 kV by two transformers. Each transformer has a nominal capacity of 20 MVA. The power supply is sufficient for LOM operations.

1.18 Environmental, Permitting and Social Considerations

1.18.1 Environmental Considerations

The Westwood environmental management systems are integrated with the Doyon site infrastructure. A number of ongoing monitoring programs and previous environmental studies have identified environmental impacts and have allowed IAMGOLD to determine the most effective mitigation and restoration strategies for the Project on completion of mining activities.

The water management plan includes pit dewatering, waste rock runoff capture, diversion systems, and storage ponds. Wastewater is collected at the Westwood mine water pond. Wells have been installed around the mine water pond to monitor the groundwater quality. All water collected in the Doyon, Grand Duc, and Westwood areas is pumped to the water management system for treatment, as required, treated via a high density sludge plant, and then discharged to the Bousquet River.

1.18.2 Closure and Reclamation Planning

Closure plans must be submitted to the relevant regulator before commencement of activities. Closure plans must be revised every five years, however, in certain cases, the regulator can require more frequent revisions. A financial guarantee is required to cover reclamation and closure costs. The closure costs presented in the following paragraphs were set in Canadian dollars, and have been converted to US dollars using a US\$:C\$ exchange rate of 1.35.

The most recent closure plan update was submitted for Westwood and Doyon in 2021, with separate closure plans for each of Doyon and Westwood. The combined closure costs for Westwood, Doyon/Grand Duc and Fayolle, including contingency and ongoing Doyon care and maintenance costs, are estimated to be approximately \$223.7 million. The 2021 Westwood closure plan was approved by the ministry in June 2024 and IAMGOLD has provided financial guarantees of \$54.2 million to date in accordance with the government's payment schedule, which will increase to \$57.24 million by 2026. The Doyon/Grand Duc closure plan was approved by the ministry in July 2024 and IAMGOLD provided financial guarantees of \$97.0 million to date in accordance with the government's payment schedule, which will increase to \$122.13 million by 2026. The Fayolle closure plan was approved by the ministry in 2022 and IAMGOLD provided financial guarantees of \$2.3 million in accordance with the government's

payment schedule, which will increase to \$3.01 million by December 19, 2024. The final Fayolle closure plan is required no later than 19 December, 2027.

1.18.3 Permitting Considerations

Prior to the start of operations at the Westwood and Grand Duc Mines, the Doyon operations held all of the environmental permits required to operate the Doyon underground mine, Doyon open pit, process plant, water treatment plant and tailings/waste rock pile. The closure plan was approved by the Ministry of Natural Resources. Mining leases were granted. Explosives permits were received from the Sûreté du Québec.

Permit applications and renewals are undertaken as required. As at the Report effective date, all material permits were in compliance or were in the analysis or renewal process.

A review indicated that some permits were missing from the Doyon closure process. IAMGOLD is undertaking new requests or plans to lodge modification of existing permits requests to address this issue.

In 2019, IAMGOLD initiated the permitting process for the progressive reclamation of the old Doyon tailing storage facility # 1 and obtained the permits in mid-2022. In 2023, IAMGOLD initiated the reclamation works and the ongoing reclamation works are expected to be completed after 2026.

1.18.4 Social Considerations

The Westwood and Grand Duc operations are in the territory identified in the agreement on consultation and accommodation between the government and the Council of the Abitibiwinni First Nation. IAMGOLD initiated discussions with the First Nations and is at the stage of concluding an agreement in principle with one First Nations community. The discussions remain ongoing until the signing of the final agreement.

No significant social challenges or opposition is expected as the majority of the infrastructure is located on or near the Doyon Mining Lease, which has been the subject of operations since 1980. As such, community and social impacts are regarded to be positive or unchanged. No new surface rights acquisitions were required during the development of the Westwood and Grand Duc mines as the location of the surface infrastructures was already held by IAMGOLD. IAMGOLD conducts annual site visits and meetings with its local stakeholders. This outreach allows stakeholders to raise concerns about the impact of the current mining plan.

1.19 Markets and Contracts

No market studies are currently relevant as Westwood and Grand Duc are operating mines producing a readily-saleable commodity in the form of doré. The terms contained within the existing sales contracts are typical and consistent with standard industry practice, and are similar to contracts for the supply of doré elsewhere in the world.

Commodity prices used in Mineral Resource and Mineral Reserve estimates are set by IAMGOLD corporately. For the purposes of this Report, the forecasts were:

- Mineral Resources:
 - US\$1,800/oz Au;
- Mineral Reserves:
 - US\$1,500/oz Au (Westwood);
 - US\$1,800/oz Au (Grand Duc).

The higher metal prices used for Mineral Reserves at Grand Duc reflect the short mine life for that deposit.

The Westwood mine has been in operation for several years and has several contracts in place to support operations. These contracts cover a large range of activities such as underground work, diamond drilling, laboratory testing services, maintenance and equipment repairs, security as well as bulk commodities and consumables. The terms of the contracts are within the mining industry norms.

All open pit mining at Grand Duc is performed by a contractor, and the terms of the mining contracts are within mining industry norms.

1.20 Capital Cost Estimates

The LOM plan assumes Owner-operated mining for the underground operations at Westwood, with mining and processing extending through to 2032. The Grand Duc open pit operations are conducted by contractors, with mining planned to end in 2025.

The LOM capital costs for Westwood are summarized in Table 1-7. Mine closure costs are not included in the table.

1.21 Operating Cost Estimates

As Westwood and Grand Duc are currently operating, the costs are primarily based on actual operating costs.

Life-of-mine operating costs are also summarized in Table 1-7.

1.22 Economic Analysis

IAMGOLD is using the provision for producing issuers, whereby producing issuers may exclude the information required under Item 22 for technical reports on properties currently in production and where no material production expansion is planned.

Mineral Reserve declaration is supported by a positive cashflow.

1.23 Risks and Opportunities

1.23.1 Risks

Factors that may affect the Mineral Resource estimates are outlined in Section 1.12. Factors that may affect the Mineral Reserve estimates are summarized in Section 1.14.

IAMGOLD has spent considerable time, effort, and capital to address the seismic issues that resulted in the temporary mine closure in 2021. IAMGOLD intends to continue the rigorous application of its ground control algorithm to minimize seismic risks.

Table 1-7: Westwood Complex - Mine Plan Summary

	Units	LOM Total or Average	2025	2026	2027	2028	2029	2030	2031	2032
Mining Operations										
<i>Westwood Underground</i>										
Ore mined	000 t	2,496	351	346	370	373	374	359	275	48
Grade mined	g/t Au	11.55	11.04	13.25	11.86	10.60	11.29	10.20	12.68	13.62
<i>Grand Duc Open Pit</i>										
Ore mined	000 t	1,129	1,129	—	—	—	—	—	—	—
Grade mined	g/t Au	1.10	1.10	—	—	—	—	—	—	—
Waste mined	000 t	1,059	1,059	—	—	—	—	—	—	—
Total mined	000 t	2,189	2,189	—	—	—	—	—	—	—
Processing										
Ore milled, underground	000 t	2,496	351	346	370	373	374	359	275	48
Ore milled, open pit	000 t	1,544	724	742	79	—	—	—	—	—
Ore milled	000 t	4,040	1,075	1,088	449	373	374	359	275	48
Head grade, underground	g/t Au	11.55	11.04	13.25	11.86	10.60	11.29	10.20	12.68	13.62
Head grade, open pit	g/t Au	0.98	1.35	0.66	0.66	—	—	—	—	—
Head grade	g/t Au	7.51	4.52	4.66	9.90	10.60	11.29	10.20	12.68	13.62
Recovery	%	95	94	95	95	95	95	95	95	95
<i>Gold production</i>	<i>000 oz</i>	<i>925</i>	<i>147</i>	<i>154</i>	<i>136</i>	<i>121</i>	<i>129</i>	<i>112</i>	<i>107</i>	<i>20</i>
Operating Cost										
Mining cost, underground	\$M	631.0	95.8	85.1	92.3	93.0	93.3	90.3	69.2	12.0

	Units	LOM Total or Average	2025	2026	2027	2028	2029	2030	2031	2032
Mining cost, open pit	\$M	15.4	14.3	0.9	0.1	—	—	—	—	—
Mining cost	\$M	646.4	110.1	86.0	92.4	93.0	93.3	90.3	69.2	12.0
Process cost	\$M	155.0	28.0	29.0	21.8	19.8	19.9	19.2	14.7	2.5
General and administrative cost	\$M	167.8	20.5	20.7	21.0	21.0	21.0	21.2	21.2	21.2
Total	\$M	969.2	158.7	135.7	135.2	133.8	134.2	130.7	105.2	35.7
Unit Costs										
Mining cost, underground	\$/t mined	252.78	272.95	245.70	249.48	249.48	249.48	251.41	251.41	251.41
Mining cost, open pit	\$/t mined	6.55	6.55	—	—	—	—	—	—	—
Mining cost	\$/t processed	160.00	102.49	79.07	206.01	249.48	249.48	251.41	251.41	251.41
Process (incl. environmental) cost	\$/t processed	38.37	26.09	26.68	48.56	53.12	53.12	53.53	53.53	53.53
General and administrative cost	\$/t processed	41.54	19.10	19.03	46.85	56.40	56.18	58.97	76.91	445.54
Capital Expenditures										
Sustaining capital expenditures	\$M	260.7	74.3	51.6	52.6	32.9	28.3	20.8	0.0	0.0
Non-sustaining capital expenditures	\$M	0.0	0.0	0.0	0.0	0.0	0.0	0.0	0.0	0.0
Total capital expenditures	\$M	260.7	74.3	51.6	52.6	32.9	28.3	20.8	0.0	0.0

Note: numbers have been rounded.

The main risk to the Project as presented in this Report is considered to be cost management. To achieve the costs used in the economic model that supports the Mineral Reserves, operations will have to monitor:

- Expenditure required to maintain aging fixed infrastructure and mobile equipment;
- Underground development, stope access, and ore delivery to the process plant occurring as scheduled;
- Labour availability given the Westwood Complex is in an area where a number of mines are competing for trained personnel.

1.23.2 Opportunities

The Westwood deposit remains open at depth, westward and locally to the east along the untested mineralized Westwood, North and Zone-2 corridors.

The Grand Duc deposit remains open westward and locally to the east.

Exploration potential remains around the former Doyon mine.

There is upside opportunity if the Indicated Mineral Resources that were not converted to Mineral Reserves can be converted with higher gold prices.

There is additional upside opportunity if Inferred Mineral Resources can be upgraded to higher confidence categories with more drilling and supporting studies.

There is also upside opportunity if prospects in proximity to the mining operations or more regional prospects can support Mineral Resource estimation, with additional technical data collection and related studies.

1.24 Interpretation and Conclusions

An economic analysis was performed in support of estimation of the Mineral Reserves; this indicated a positive cash flow using the assumptions detailed in this Report.

1.25 Recommendations

As the Westwood Complex is an operating mine, and risks identified to the Mineral Resources and Mineral Reserves will be managed as part of normal operations, the QPs have no meaningful recommendations to make.

2 INTRODUCTION

2.1 Introduction

Mr. Bernard Haley, P.Eng., Mr. Abderrazak Ladidi, P.Geo., Mr. Martin Perron, P.Eng., Mr. Louis Nkoy Manda Mbomba, P.Eng., Dr. Ali Jalbout, P.Eng. and Mr. Steve Pelletier, P.Eng., have prepared this technical report (the Report) on the Westwood Complex (or the Project) in Quebec, Canada for IAMGOLD Corporation (IAMGOLD). The Project location is shown in Figure 2-1.

IAMGOLD holds a 100% interest in the Project.

The Project consists of two property areas, Doyon-Westwood and Fayolle:

- The Doyon-Westwood property includes the Westwood underground mine (Westwood), and Grand Duc open pit (Grand Duc), collectively the Westwood Complex. The Westwood mine has been in operation since 2014, when commercial production was declared, and Grand Duc since October, 2019. The property area includes two former mining operations, Doyon and Mouska;
- The Fayolle property. Open pit operations at the Fayolle deposit commenced in February 2023 and the deposit was mined out in June 2024. The open pit and associated infrastructure were being reclaimed at the Report effective date.

2.2 Terms of Reference

The Report was prepared to support disclosure of an updated Mineral Resource and Mineral Reserve estimate and mine plan as announced on 5 December, 2024 in IAMGOLD's news release titled "IAMGOLD Provides Westwood Updated Mine Plan and Mineral Resource & Mineral Reserve Estimates".

Updated Mineral Resource and Mineral Reserve estimates and an updated life-of-mine plan are provided for Westwood and Grand Duc in this Report.

Units used in the report are metric units unless otherwise noted. Monetary units are in United States dollars (US\$) unless otherwise stated. The Report uses Canadian English.

Figure 2-1: Project Location Map

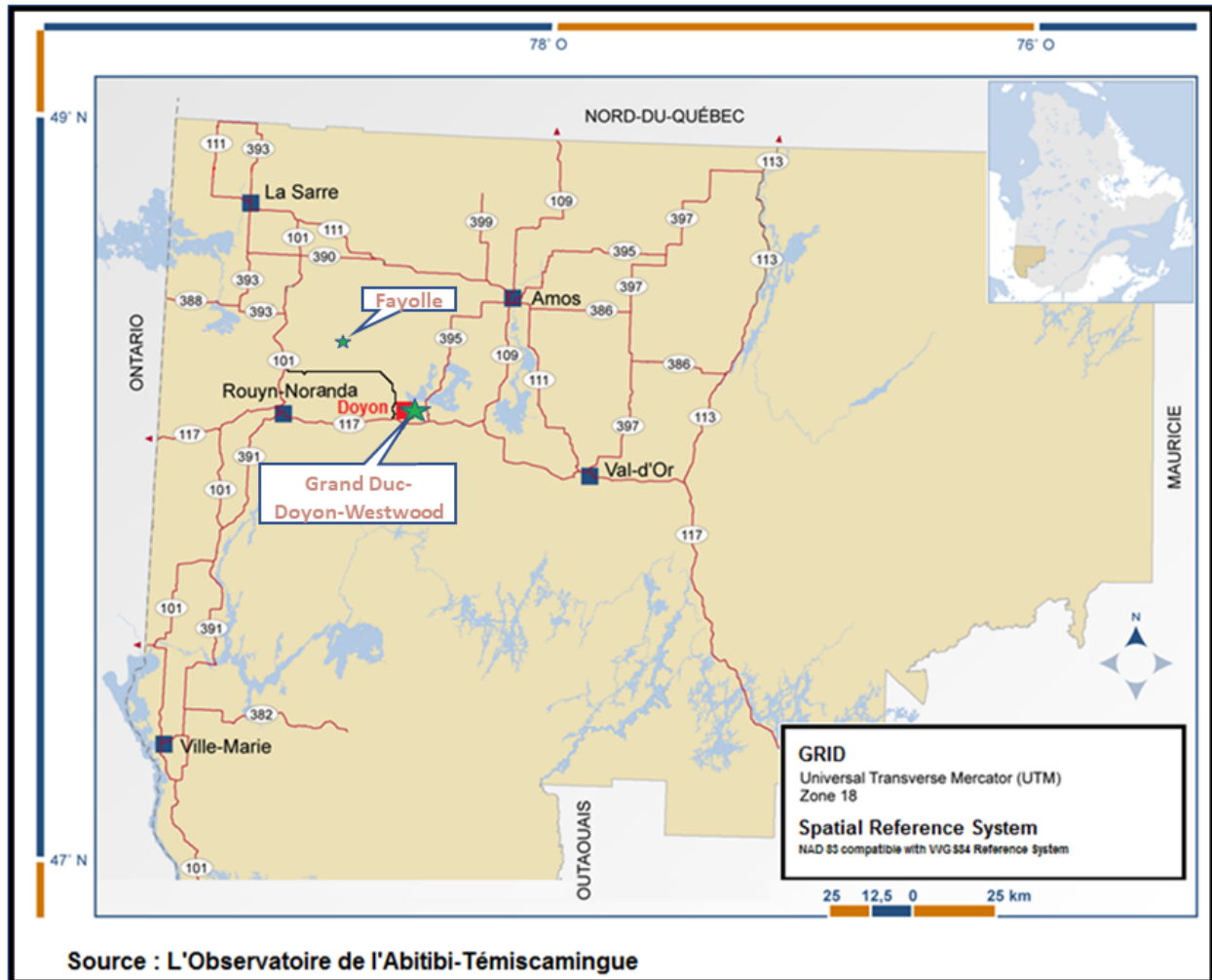

Note: Figure prepared by IAMGOLD, 2021.

Mineral Resources and Mineral Reserves are reported in accordance with the Canadian Institute of Mining, Metallurgy and Petroleum (CIM) Definition Standards for Mineral Resources and Mineral Reserves (May 2014; the 2014 CIM Definition Standards) and were prepared with reference to the CIM Estimation of Mineral Resources & Mineral Reserves Best Practice Guidelines (November, 2019; the 2019 CIM Estimation Guidelines).

2.3 Qualified Persons

The following serve as the qualified persons (QPs) for this Report as defined in National Instrument 43-101, Standards of Disclosure for Mineral Projects, and in compliance with Form 43-101F1:

- Mr. Bernard Haley, P.Eng., Mining Manager, IAMGOLD;
- Mr. Abderrazak Ladidi, P.Geo., Principal Resource Geologist, IAMGOLD;
- Mr. Martin Perron, P.Eng., Director, Centre of Excellence, Geology, Norda Stelo Inc. (Norda Stelo);
- Mr. Louis Nkoy Manda Mbomba, P.Eng., Superintendent Mine Engineering, IAMGOLD;
- Dr. Ali Jalbout; P.Eng., Principal - Geotechnical Specialist, ASA Geotech Inc.;
- Mr. Steve Pelletier, P.Eng., Principal Director, Environment, IAMGOLD.

2.4 Site Visits and Scope of Personal Inspection

2.4.1 Mr. Bernard Haley

Mr. Bernard Haley works at the Westwood Operations and has done since 2021. While on site, he has inspected the underground and open pit mines, viewed the mining-related infrastructure including the process plant, tailings storage facility, stockpiles, waste rock storage facilities, haul roads, and workshop facilities, visited major site infrastructure including the process plant, tailings storage facility, the ore stockpiles, and the waste rock storage facility. Mr. Haley has reviewed long-term mine and process plans, discussed aspects of environmental, social, and permitting for operations with relevant staff, reviewed capital and operating cost estimates, and reviewed the economic analysis and its inputs that support Mineral Reserves.

2.4.2 Mr. Abderrazak Ladidi

Mr. Abderrazak Ladidi works at the Westwood Operations. He has been an IAMGOLD employee since June 2020. While on site, he has reviewed geological interpretations with staff, supervised and reviewed modeling efforts, supervised mineral resource estimates, verified, and reviewed on-site data including modeling programs and sampling results, visited underground workings, followed up on quality assurance and quality control (QA/QC) measures with operations staff and viewed the location of infrastructure at the Westwood Complex.

2.4.3 Mr. Louis Nkoy Manda Mbomba

Mr. Louis Nkoy Manda Mbomba has been working at the Westwood Operations since March 2020. During his time on-site, he has inspected both the underground and open pit mines, as well as the mining-related infrastructure, including the tailings storage facility, stockpiles, waste rock storage facilities, haul

roads, and workshop facilities. He has visited key site infrastructure such as the tailings storage facility, ore stockpiles, and waste rock storage facility. He has also held regular discussions with the geology department. Additionally, he supervised the preparation of the long-term mine plan and reviewed all aspects of the plan, including Mineral Reserve estimation practices, mine designs, equipment requirements, personnel, costs, and operational performance.

2.4.4 Dr. Ali Jalbout

Dr. Jalbout has been working at the Westwood Operations since March 2020. His most recent site visit was on 2 October, 2024. He has visited underground working areas to ensure QA/QC measures with operations staff, and viewed the location of infrastructure at the Westwood Operations.

2.4.5 Mr. Steve Pelletier

Mr. Pelletier worked directly at the Westwood Operations from February 2020 to May 2023, as the Sustainable Development Manager. He continues to support the operations in his subsequent as IAMGOLD's corporate Environment Director. His most recent site visits include 16–19 October 2023, 26–29 February 2024, 22–24 May 2024, and 26–29 August 2024. He has reviewed all of the environmental procedures and closure plans for the operations since February 2020. During his site visits, Mr. Pelletier visited surface and underground working areas, to ensure the environmental and health and safety practices of operations staff were in compliance with the permits and regulations. He viewed the location of infrastructure at the Westwood Operations and the former Fayolle open pit.

2.5 Effective Dates

The Report has a number of effective dates including:

- Date of last drilling information included in the Report: 1 October, 2024;
- Date of latest information on environmental, permitting, and social considerations: 31 August, 2024;
- Date of closure of Westwood database used for resource estimation: 14 November, 2023;
- Date of closure of Grand Duc database used for resource estimation: 15 November, 2023;
- Date of Mineral Resource estimate for Westwood: 30 September 2024;
- Date of Mineral Resource estimate for Grand Duc: 30 September 2024;
- Date of Mineral Reserve estimates: 30 September, 2024.

The overall effective date of the Report is the date of the Mineral Reserve estimate, which is 30 September, 2024.

2.6 Information Sources and References

The reports and documents listed in Section 2.7 and Section 27 of this Report were used to support the preparation of the Report.

Additional information was sought from IAMGOLD personnel where required.

2.7 Previous Technical Reports

IAMGOLD has previously filed the following technical reports on the Doyon-Westwood portion of the Project area:

- Sirios, R., Vallières, D., and Pelletier, P., 2009: National Instrument 43-101 Technical Report for Westwood Project, Québec, Canada: report prepared for IAMGOLD Corporation, effective date 18 February, 2009;
- Savoie, A., Morel, R., and Ferland, F., 2013: Westwood Project, Quebec, Canada, NI 43-101 Technical Report Mineral Resource and Reserve Estimate as at December 31, 2012: report prepared for IAMGOLD Corporation, effective date 16 October, 2013;
- Leber, R.G., Williams, E., Girard, J., and Vallières, D., 2016: Westwood Mine, NI 43-101 Technical Report as of December 31, 2016: report prepared for IAMGOLD Corporation, effective date 31 December, 2016;
- Gauthier, M., Trudel, D., Charles, C., Landry, N., Deshaies, M., Ferland, P., Pelletier, S., and Chabot, P., 2020: Technical Report For The Westwood Mine, Quebec, Canada: report prepared for IAMGOLD Corporation, effective date 30 April, 2020.

Prior to IAMGOLD's property interest, the following companies had filed technical reports on the Fayolle property:

- Carrier, A., 2007: Évaluation des Ressources Minérales Du Gîte Aurifère Fayolle et Rapport Technique Conforme Au Règlement 43-101: report prepared by InnovExplo Inc. for Typhoon Exploration Inc., effective date 21 February, 2007;

- Carrier, A. Richard, P-L. Turcotte, B., and Gomwe, T., 2012. Technical Report on the Fayolle Property (according to Regulation 43-101 and Form 43-101F1): report prepared by InnovExplo Inc. for Typhoon Exploration Inc., effective date 9 October, 2012;
- Poirier, S., Carrier, A., Tremblay, A. and Isabel, D., 2013: Technical Report and Preliminary Economic Assessment for the Fayolle Property (compliant with Regulation 43-101 and Form 43-101F1): report prepared by InnovExplo Inc. for Typhoon Exploration Inc, effective date 28 March 28, 2013;
- Gaudreault, D., and Beauregard, A. J., 2015: Technical Report (including a synthesis of 3D compilation of exploration work), Aiguebelle, Cléricy, Destor Townships, Abitibi, Quebec, NTS 32 D/07: report prepared by Geologica Groupe-Conseil Inc for Typhoon Exploration., effective date 7 July, 2015;
- Carrier, A., and Beausoleil, C., 2019: NI 43-101 Technical Report and Mineral Resource Estimate for the Fayolle Gold Project, Québec, Canada: report prepared by InnovExplo Inc. for Monarch Gold Corporation, effective date 30 August, 2019.

3 RELIANCE ON OTHER EXPERTS

This section is not relevant to this Report.

4 PROPERTY DESCRIPTION AND LOCATION

4.1 Location

The Project is located in the province of Québec, Canada at a latitude of 48°15' N and a longitude of 78°30' W.

The Westwood and Grand Duc deposits are located in the municipality of Preissac, Bousquet Township, approximately 40 km east of the town of Rouyn-Noranda and 80 km west of the town of Val d'Or. The Westwood shaft is located at 48°15'20.6"N 78°30'07.9"W and the Grand Duc pit is located at 48°15'30.8"N 78°32'27.6"W.

The Fayolle property is located in Aiguebelle and Cléricy townships, approximately 35 km northeast of Rouyn-Noranda, Québec, and approximately 40 km northwest of the Westwood mine. The approximate centre of the Fayolle property area is at a latitude of 48°26' N and a longitude of 78°48' W (NAD 83, Zone 17). The Fayolle property is <1 km from the provincial "Parc national d'Aiguebelle" (Aiguebelle National Park).

There are previously operating mines in the Project area, the most significant of which are Doyon and Mouska situated 1.7 km and 4.8 km west of the from the Westwood mine respectively (refer to Figure 4-1).

4.2 Ownership

The Doyon-Westwood property is wholly-owned by IAMGOLD.

IAMGOLD acquired the Fayolle property from Monarch Gold Corp. (Monarch) in 2020.

4.3 Mineral Tenure

4.3.1 Doyon-Westwood Property

The Doyon-Westwood property extends over about 8 km east–west by approximately 5 km north–south (Figure 4-2).

Figure 4-1: Mining Operation Location Map

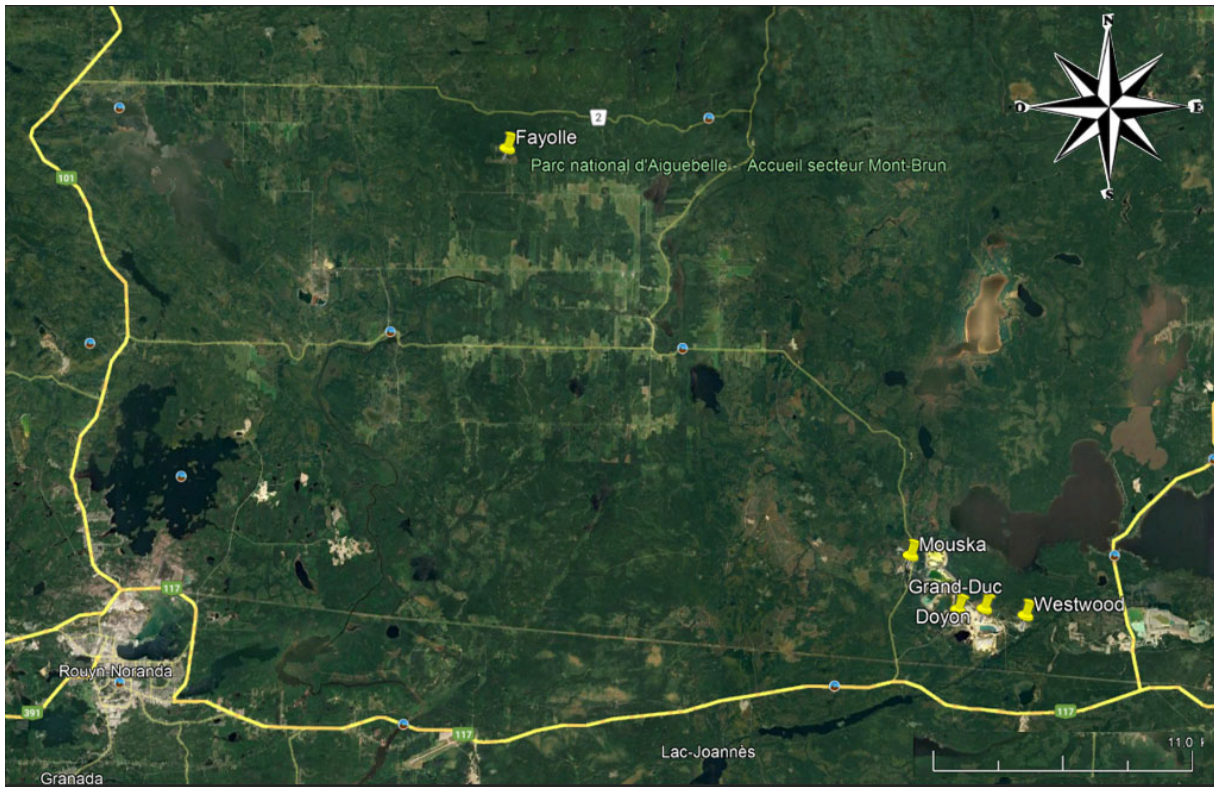

Note: Figure prepared by IAMGOLD, 2024, using Google Earth backdrop. Pushpins denote IAMGOLD mining operations. Westwood and Grand Duc are current operations. Mouska, Doyon and Fayolle are former operations.

Figure 4-2: Doyon-Westwood Property

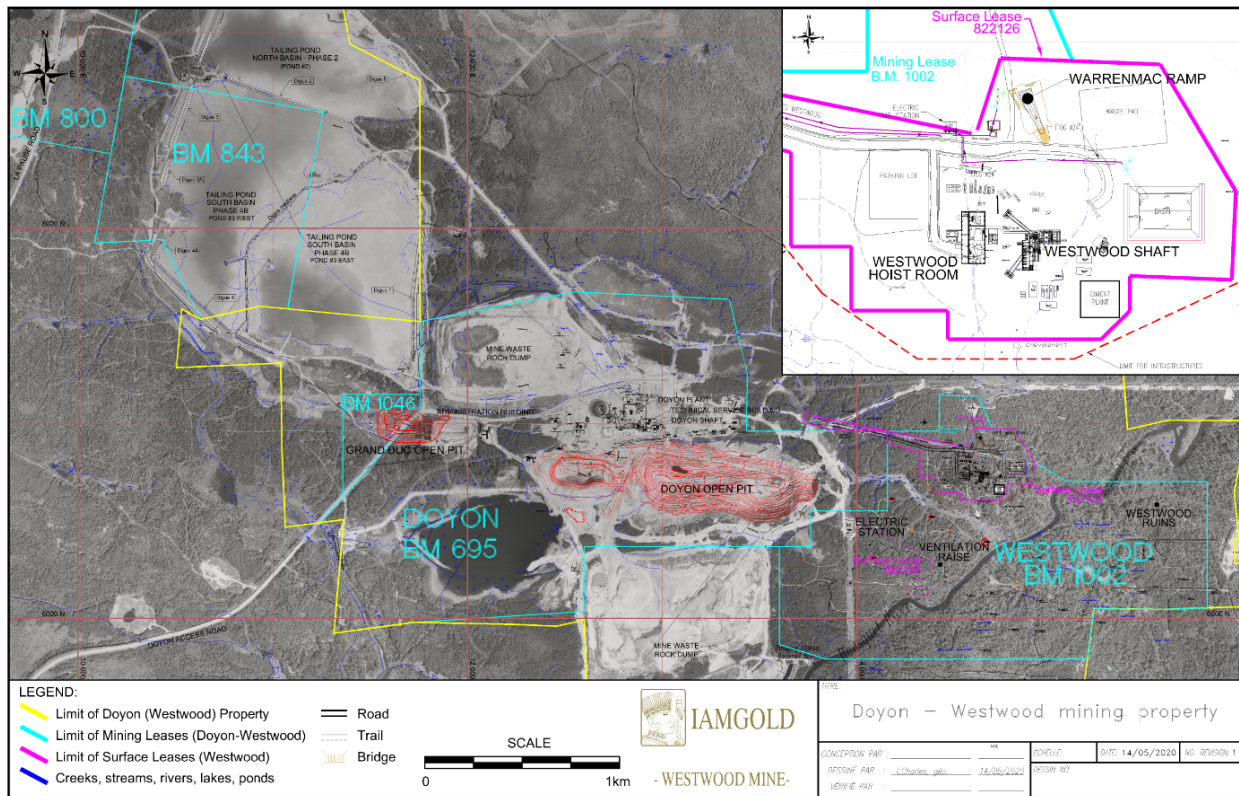

Note: Figure prepared by IAMGOLD, 2024.

In 2008, a surface lease (No. 822126) was surveyed to define areas for the Westwood exploration shaft site, the Warrenmac ramp, and access roads. A portion of surface lease No. 822126, which covers a part of the access road between the Doyon Mine and the Westwood Mine is still outside the Westwood Mining Lease, B.M. 1002, and has been maintained.

On 16 April, 2010, an application was filed with the Ministère de l'Énergie et des Ressources Naturelles (MERN) to request a mining lease for Westwood site development. The Westwood Mining Lease (B.M. 1002) was granted on 23 April, 2012, for a total of 196.23 ha, and covers lots 4301148, 4399767, 4606905, 4606906, 4606907, and 4606971 of the Québec Cadastre, as well as non-registered land in the river bed of the Bousquet River, in the township of Bousquet, Registration Division of Rouyn-Noranda.

In 2014, MERN completed a conversion process to replace all ground-staked mineral claims forming the Doyon-Westwood property with map-designated cells to simplify the land tenure system. In addition, three tailings surface leases (P.R. 999780, P.R. 999794, and P.R. 999803) are superimposed over parts of the Doyon-Westwood property. The titleholder of all claims and leases forming the property is IAMGOLD (100%) and all Doyon-Westwood property claims and leases are located in Bousquet Township.

The Doyon-Westwood property consists of 80 mineral titles, covering an area of 3,294.57 ha, of which five are mining leases (bail minier or BM), and 75 are map-designated cells (cellule désignée sur carte or CDC). The mineral titles are listed in Table 4-1 and shown on Figure 4-3.

Mining leases in Québec are initially valid for 20 years and may be extended for up to three additional periods of 10 years. However, it is possible to extend the mining lease for additional periods of five years after the third renewal. Except for the first period of validity which is of three years, the mineral claims are valid for periods of two years, to the extent that the holder meets the conditions provided for under the Mining Act. All claims are in good standing as at the Report effective date. IAMGOLD will renew claims as needed using the standard renewal process in Quebec.

Fees for mining leases and tailing surface leases are due to MERN annually by their anniversary dates, which, in the case of the Doyon-Westwood property, range from January to July.

In Québec, the rent of each mineral claim primarily depends on its holding time and location. The rent per full-size cell mineral claim is \$57.04 per two-year period while mineral claims formed from a small fraction of the cell have a rent of \$29.26 per two-year period. Work requirements per mineral claim generally vary from \$800 to \$2,000 per two-year period depending on the claim size. Any excess of work credits may be applied for subsequent renewals.

To accumulate credits on mineral claims, a technical report detailing exploration activities (type, time, location, costs, results, responsible persons, and utilized contractor(s)) must be filed with MERN as statutory work. These reports must be filed within two years of the expenditures that have been incurred.

4.3.2 Fayolle Property

The Fayolle property consists of 42 mineral titles covering an area of 1,382.62 ha in Aiguebelle and Cléricy townships, of which one is a mining lease and the remaining 41 titles are map-designated cells. The mineral titles are listed in Table 4-2 and shown on Figure 4-4.

All claims are in good standing as at the Report effective date. IAMGOLD will renew claims as needed using the standard renewal process in Quebec.

Table 4-1: Doyon-Westwood Property Mineral Claims and Mining Leases

Title/Claim Number		N.T.S. Sheet	Township	Row	Column	Status	Registration Date	Expiration Date	Surface Area (ha)
BM	695	SNRC 32D02, D07	Bousquet	000E	0	Active	1980-07-03	2030-07-02	312.51
BM	800	SNRC 32D07	Bousquet	37	0	Active	1991-08-07	2031-08-06	133.65
BM	843	SNRC 32D07	Bousquet	46	0	Active	1998-04-06	2028-04-05	99.76
BM	1002	SNRC 32D01, D02, D07, D08	Bousquet	L460	6906	Active	2012-04-23	2032-04-22	196.23
BM	1046	SNRC 32D07	Bousquet	L570	4151	Active	2017-01-19	2037-01-18	11.89
CDC	2412474	SNRC 32D02	Bousquet	30	58	Active	2014-10-28	2026-07-04	57.35
CDC	2412475	SNRC 32D07	Bousquet	1	58	Active	2014-10-28	2026-07-04	15.75
CDC	2412476	SNRC 32D02	Bousquet	30	60	Active	2014-10-28	2026-07-04	32.33
CDC	2412477	SNRC 32D02	Bousquet	29	58	Active	2014-10-28	2026-07-04	1.16
CDC	2412478	SNRC 32D02	Bousquet	29	60	Active	2014-10-28	2026-07-04	0.64
CDC	2412479	SNRC 32D07	Bousquet	1	59	Active	2014-10-28	2026-07-04	0.85
CDC	2412480	SNRC 32D07	Bousquet	1	57	Active	2014-10-28	2026-07-04	8.91
CDC	2412481	SNRC 32D01	Bousquet	30	1	Active	2014-10-28	2026-07-04	19.24
CDC	2412482	SNRC 32D01	Bousquet	30	2	Active	2014-10-28	2026-07-04	2.60
CDC	2412483	SNRC 32D02	Bousquet	29	59	Active	2014-10-28	2026-07-04	1.02
CDC	2412484	SNRC 32D02	Bousquet	29	57	Active	2014-10-28	2026-07-04	0.66
CDC	2412485	SNRC 32D02	Bousquet	30	56	Active	2014-10-28	2026-07-04	1.80
CDC	2412486	SNRC 32D02	Bousquet	30	59	Active	2014-10-28	2026-07-04	39.40
CDC	2412487	SNRC 32D02	Bousquet	30	57	Active	2014-10-28	2026-07-04	32.22
CDC	2412874	SNRC 32D07	Bousquet	2	52	Active	2014-11-12	2026-12-19	57.33

Title/Claim Number		N.T.S. Sheet	Township	Row	Column	Status	Registration Date	Expiration Date	Surface Area (ha)
CDC	2412875	SNRC 32D07	Bousquet	3	58	Active	2014-11-12	2026-12-19	57.32
CDC	2412876	SNRC 32D07	Bousquet	3	59	Active	2014-11-12	2026-12-19	57.32
CDC	2412877	SNRC 32D07	Bousquet	3	60	Active	2014-11-12	2026-12-19	57.33
CDC	2412878	SNRC 32D07	Bousquet	4	56	Active	2014-11-12	2026-12-19	57.31
CDC	2412879	SNRC 32D07	Bousquet	4	58	Active	2014-11-12	2026-12-19	57.32
CDC	2412880	SNRC 32D07	Bousquet	4	60	Active	2014-11-12	2026-12-19	57.32
CDC	2412881	SNRC 32D07	Bousquet	4	57	Active	2014-11-12	2026-12-19	57.32
CDC	2412882	SNRC 32D07	Bousquet	4	55	Active	2014-11-12	2026-12-19	57.31
CDC	2412883	SNRC 32D07	Bousquet	3	56	Active	2014-11-12	2026-12-19	57.32
CDC	2412884	SNRC 32D07	Bousquet	3	57	Active	2014-11-12	2026-12-19	57.32
CDC	2412885	SNRC 32D07	Bousquet	2	59	Active	2014-11-12	2026-12-19	57.33
CDC	2412886	SNRC 32D07	Bousquet	4	59	Active	2014-11-12	2026-12-19	57.32
CDC	2412887	SNRC 32D08	Bousquet	4	1	Active	2014-11-12	2026-12-19	57.32
CDC	2412888	SNRC 32D07	Bousquet	2	60	Active	2014-11-12	2026-12-19	55.11
CDC	2412889	SNRC 32D07	Bousquet	5	58	Active	2014-11-12	2026-12-19	57.31
CDC	2412890	SNRC 32D07	Bousquet	5	57	Active	2014-11-12	2026-12-19	57.31
CDC	2412891	SNRC 32D07	Bousquet	5	59	Active	2014-11-12	2026-12-19	57.31
CDC	2412892	SNRC 32D07	Bousquet	4	51	Active	2014-11-12	2026-12-19	7.83
CDC	2412893	SNRC 32D07	Bousquet	5	60	Active	2014-11-12	2026-12-19	57.31
CDC	2412894	SNRC 32D08	Bousquet	3	1	Active	2014-11-12	2026-12-19	57.33
CDC	2412895	SNRC 32D07	Bousquet	2	53	Active	2014-11-12	2026-12-19	55.95

Title/Claim Number		N.T.S. Sheet	Township	Row	Column	Status	Registration Date	Expiration Date	Surface Area (ha)
CDC	2412896	SNRC 32D07	Bousquet	4	54	Active	2014-11-12	2026-12-19	57.31
CDC	2412897	SNRC 32D07	Bousquet	4	52	Active	2014-11-12	2026-12-19	1.58
CDC	2412898	SNRC 32D07	Bousquet	1	60	Active	2014-11-12	2026-12-19	1.90
CDC	2412899	SNRC 32D01	Bousquet	30	2	Active	2014-11-12	2026-12-19	1.15
CDC	2412900	SNRC 32D08	Bousquet	2	1	Active	2014-11-12	2026-12-19	44.44
CDC	2412902	SNRC 32D07	Bousquet	3	55	Active	2014-11-12	2026-12-19	49.97
CDC	2412904	SNRC 32D07	Bousquet	2	57	Active	2014-11-12	2026-12-19	18.84
CDC	2412905	SNRC 32D02	Bousquet	30	52	Active	2014-11-12	2026-12-19	4.84
CDC	2412907	SNRC 32D07	Bousquet	1	59	Active	2014-11-12	2026-12-19	4.90
CDC	2412908	SNRC 32D07	Bousquet	2	51	Active	2014-11-12	2026-12-19	49.26
CDC	2412909	SNRC 32D07	Bousquet	2	58	Active	2014-11-12	2026-12-19	29.51
CDC	2412910	SNRC 32D07	Bousquet	5	54	Active	2014-11-12	2026-12-19	57.30
CDC	2412911	SNRC 32D07	Bousquet	1	60	Active	2014-11-12	2026-12-19	0.85
CDC	2412912	SNRC 32D07	Bousquet	3	53	Active	2014-11-12	2026-12-19	12.47
CDC	2412913	SNRC 32D07	Bousquet	5	56	Active	2014-11-12	2026-12-19	57.31
CDC	2412914	SNRC 32D08	Bousquet	1	2	Active	2014-11-12	2026-12-19	26.51
CDC	2412915	SNRC 32D07	Bousquet	5	53	Active	2014-11-12	2026-12-19	56.84
CDC	2412916	SNRC 32D07	Bousquet	3	50	Active	2014-11-12	2026-12-19	15.14
CDC	2412917	SNRC 32D07	Bousquet	2	55	Active	2014-11-12	2025-12-12	52.57
CDC	2412918	SNRC 32D08	Bousquet	1	1	Active	2014-11-12	2026-12-19	17.95
CDC	2412919	SNRC 32D07	Bousquet	4	53	Active	2014-11-12	2026-12-19	31.17

Title/Claim Number		N.T.S. Sheet	Township	Row	Column	Status	Registration Date	Expiration Date	Surface Area (ha)
CDC	2412920	SNRC 32D07	Bousquet	1	52	Active	2014-11-12	2026-12-19	49.68
CDC	2412921	SNRC 32D08	Bousquet	3	2	Active	2014-11-12	2026-12-19	52.56
CDC	2412922	SNRC 32D07	Bousquet	3	54	Active	2014-11-12	2026-12-19	13.17
CDC	2412923	SNRC 32D07	Bousquet	1	53	Active	2014-11-12	2026-12-19	52.01
CDC	2412924	SNRC 32D07	Bousquet	3	53	Active	2014-11-12	2026-12-19	3.10
CDC	2412925	SNRC 32D07	Bousquet	3	52	Active	2014-11-12	2026-12-19	35.86
CDC	2412926	SNRC 32D07	Bousquet	4	50	Active	2014-11-12	2026-12-19	5.97
CDC	2412927	SNRC 32D07	Bousquet	1	58	Active	2014-11-12	2026-12-19	1.04
CDC	2412928	SNRC 32D07	Bousquet	5	52	Active	2014-11-12	2026-12-19	51.41
CDC	2412929	SNRC 32D07	Bousquet	2	54	Active	2014-11-12	2026-12-19	35.29
CDC	2412930	SNRC 32D07	Bousquet	5	55	Active	2014-11-12	2026-12-19	57.31
CDC	2412931	SNRC 32D02	Bousquet	30	53	Active	2014-11-12	2026-12-19	7.16
CDC	2412932	SNRC 32D07	Bousquet	1	55	Active	2014-11-12	2025-12-12	14.35
CDC	2412933	SNRC 32D07	Bousquet	3	51	Active	2014-11-12	2026-12-19	52.97
CDC	2412934	SNRC 32D07	Bousquet	1	51	Active	2014-11-12	2026-12-19	27.86
CDC	2412935	SNRC 32D07	Bousquet	1	54	Active	2014-11-12	2026-12-19	32.63
CDC	2412936	SNRC 32D07	Bousquet	2	56	Active	2014-11-12	2025-12-12	25.89
CDC	2412937	SNRC 32D08	Bousquet	2	2	Active	2014-11-12	2026-12-19	8.59

Note: BM = bail minier or mining lease; CDC = cellule désignée sur carte or map designated cell.

Figure 4-3: Doyon-Westwood Mineral Title Location Map

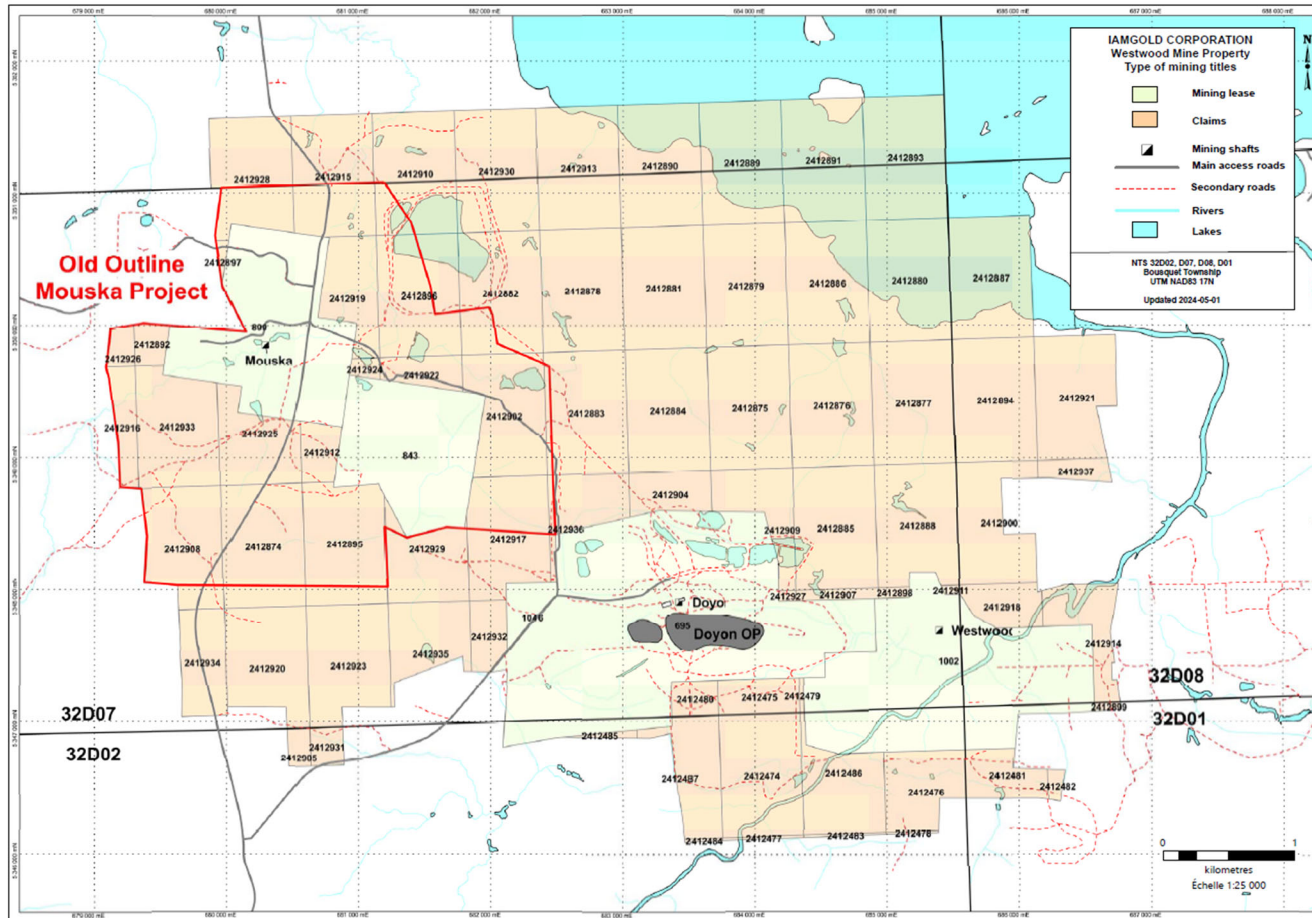

Note: Figure prepared by IAMGOLD, 2024. Note: BM = bail minier or mining lease; CDC = cellule désignée sur carte or map designated cell.

Table 4-2: Fayolle Project Mineral Claims and Mining Leases

Title/Claim Number		N.T.S. Sheet	Canton	Row	Column	Status	Registration Date (YYYY-MM-DD)	Expiration Date (YYYY-MM-DD)	Surface Area (ha)
BM	1060	SNRC 32D07	CLERICY	23	24	Active	2023-02-20	2043-02-19	39.00
CL	3815201	SNRC 32D07	CLERICY	10	24	Active	1979-10-05	2026-09-16	31.00
CL	3815202	SNRC 32D07	CLERICY	10	25	Active	1979-10-05	2026-09-16	31.00
CL	3815211	SNRC 32D07	CLERICY	10	26	Active	1979-10-05	2026-09-16	31.00
CL	3815212	SNRC 32D07	AIGUEBELLE	1	24	Active	1979-10-05	2026-09-16	40.00
CL	3815221	SNRC 32D07	CLERICY	10	16	Active	1979-10-05	2026-09-18	31.00
CL	3815222	SNRC 32D07	CLERICY	10	17	Active	1979-10-05	2026-09-18	31.00
CL	3844562	SNRC 32D07	AIGUEBELLE	1	25	Active	1979-10-05	2026-09-13	40.00
CL	3844571	SNRC 32D07	AIGUEBELLE	1	20	Active	1979-10-05	2026-09-15	40.00
CL	3844572	SNRC 32D07	AIGUEBELLE	1	21	Active	1979-10-05	2026-09-15	40.00
CL	3844721	SNRC 32D07	AIGUEBELLE	1	16	Active	1979-10-05	2025-01-24	37.71
CL	384472A	SNRC 32D07	AIGUEBELLE	1	17	Active	1979-10-05	2025-01-24	18.54
CL	384472B	SNRC 32D07	AIGUEBELLE	1	17	Active	1979-10-05	2025-01-24	10.91
CL	3844731	SNRC 32D07	CLERICY	10	18	Active	1979-10-05	2026-09-17	31.00
CL	3844732	SNRC 32D07	CLERICY	10	19	Active	1979-10-05	2026-09-17	31.00
CL	384476A	SNRC 32D07	AIGUEBELLE	1	18	Active	1979-10-05	2025-01-24	18.54
CL	384476B	SNRC 32D07	AIGUEBELLE	1	18	Active	1979-10-05	2025-01-24	10.88
CL	3844762	SNRC 32D07	AIGUEBELLE	1	19	Active	1979-10-05	2025-01-24	34.04
CL	3844771	SNRC 32D07	CLERICY	10	20	Active	1979-10-05	2026-09-17	31.00

Title/Claim Number		N.T.S. Sheet	Canton	Row	Column	Status	Registration Date (YYYY-MM-DD)	Expiration Date (YYYY-MM-DD)	Surface Area (ha)
CL	3844772	SNRC 32D07	CLERICY	10	21	Active	1979-10-05	2026-09-17	31.00
CL	3849551	SNRC 32D07	AIGUEBELLE	1	22	Active	1979-10-05	2026-09-18	40.00
CL	3849552	SNRC 32D07	AIGUEBELLE	1	23	Active	1979-10-05	2026-09-18	40.00
CL	3849561	SNRC 32D07	CLERICY	10	14	Active	1979-10-05	2026-09-18	31.00
CL	3849562	SNRC 32D07	CLERICY	10	15	Active	1979-10-05	2026-09-18	31.00
CL	3849571	SNRC 32D07	CLERICY	10	22	Active	1979-10-05	2026-09-18	31.00
CL	3849572	SNRC 32D07	CLERICY	10	23	Active	1979-10-05	2026-09-18	31.00
CL	3880131	SNRC 32D07	CLERICY	9	21	Active	1980-03-18	2026-03-01	40.00
CL	3880132	SNRC 32D07	CLERICY	9	22	Active	1980-03-18	2026-03-01	40.00
CL	3880141	SNRC 32D07	CLERICY	9	23	Active	1980-03-18	2026-03-01	40.00
CL	3880172	SNRC 32D07	CLERICY	9	20	Active	1980-03-18	2026-03-01	40.00
CL	4264871	SNRC 32D07	CLERICY	10	7	Active	1985-07-15	2026-06-13	31.00
CL	4264872	SNRC 32D07	CLERICY	10	8	Active	1985-07-15	2026-06-13	31.00
CL	4264881	SNRC 32D07	CLERICY	10	9	Active	1985-07-15	2026-06-13	31.00
CL	4264882	SNRC 32D07	CLERICY	10	10	Active	1985-07-15	2026-06-13	31.00
CL	4264891	SNRC 32D07	CLERICY	10	11	Active	1985-07-15	2026-06-13	31.00
CL	4264892	SNRC 32D07	CLERICY	10	12	Active	1985-07-15	2026-06-13	31.00
CL	4264901	SNRC 32D07	CLERICY	10	13	Active	1985-07-15	2026-06-13	31.00
CL	4510641	SNRC 32D07	CLERICY	8	48	Active	1986-11-06	2026-10-04	42.00
CL	4569612	SNRC 32D07	CLERICY	10	31	Active	1987-11-26	2026-10-07	31.00

Title/Claim Number		N.T.S. Sheet	Canton	Row	Column	Status	Registration Date (YYYY-MM-DD)	Expiration Date (YYYY-MM-DD)	Surface Area (ha)
CL	4572573	SNRC 32D07	AIGUEBELLE	1	28	Active	1987-08-11	2026-08-10	40.00
CL	4573753	SNRC 32D07	AIGUEBELLE	1	26	Active	1987-08-11	2026-08-10	40.00
CL	4573775	SNRC 32D07	AIGUEBELLE	1	27	Active	1987-08-11	2026-08-10	40.00

Note: BM = bail minier or mining lease; CL = mining claim.

Figure 4-4: Fayolle Mineral Title Location Map

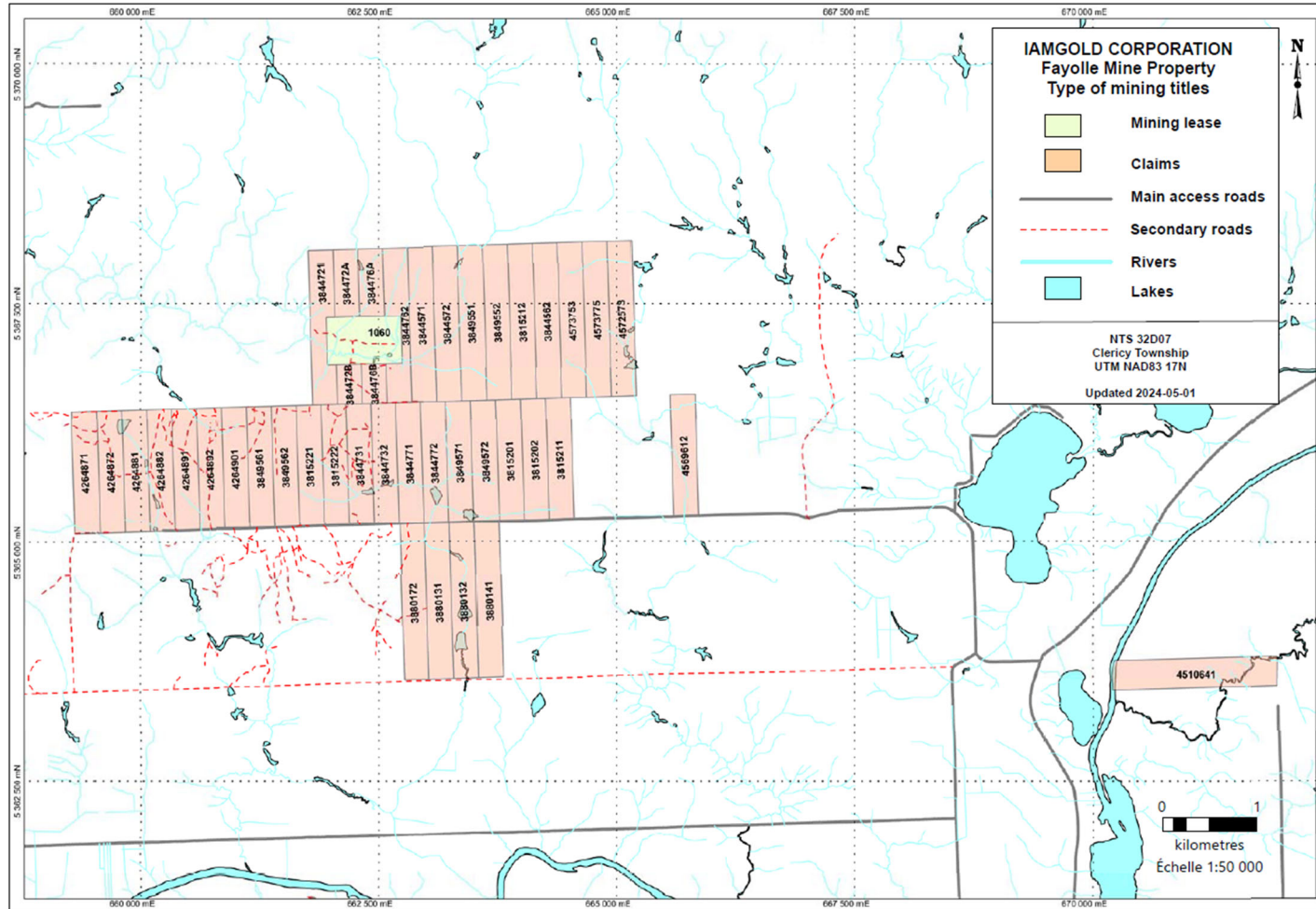

Note: Figure prepared by IAMGOLD, 2024. BM = bail minier or mining lease.

4.3.3 Legal Surveys

The southeastern part of the Doyon-Westwood Property boundary was surveyed by J.-P. Deslauriers, A.G., in April 1978. This survey covers the boundary starting from the western border of the Doyon Mining Lease (B.M. 0695) (refer to Figure 4-3) to the eastern limit of the claims.

The legal survey for the Westwood Mining Lease (B.M. 1002) was conducted by J. L. Corriveau, A.G, in 2010.

Other surveys were conducted over different blocks within and adjacent to the Property including, 1979 (J.-P. Deslauriers, A.G.; Mouska area), 1982/83 (J.-L. Corriveau, A.G.; around B.M. 0695), 1990 (J.-L. Corriveau, A.G.; Mouska and West areas) and 1992 (J.-L. Corriveau, A.G.; tailing ponds areas). All the surveys were used to support the MERN conversion of ground-staked mineral claims into map designated cells.

4.4 Surface Rights

IAMGOLD holds all of the relevant surface rights to support the LOM plan envisaged in this Report.

4.5 Water Rights

IAMGOLD holds all of the relevant water rights to support the LOM plan envisaged in this Report. IAMGOLD is actively evaluating water recycling and re-use options to reduce the operational reliance on surface waters.

4.6 Royalties and Encumbrances

The Doyon-Westwood property is not subject to any royalties or any other encumbrances.

Globex Mining Enterprises Inc. (Globex) holds a 2% net smelter return (NSR) royalty on the mineral claims within the Fayolle property.

IAMGOLD is in discussions relating to potential royalty payments to First Nations.

4.7 Permitting Considerations

Permitting considerations for the Westwood Complex are discussed in Section 20.

4.8 Environmental Considerations

Environmental considerations for the Westwood Complex are discussed in Section 20.

Current liabilities with respect to the environment primarily consist of the existing open pits, mine roads, exploration roads, former mine sites, process plant, waste rock storage facilities and the tailings storage facilities.

Liabilities and closure considerations associated with the Westwood Complex are provided in Section 20.

4.9 Social Considerations

Social considerations for the Westwood Complex are discussed in Section 20.

4.10 QP Comment on Item 4 “Property Description and Location”

To the extent known to the QP, there are no other significant factors or risks that may affect access, title, or the right or ability to perform work on the Project that are not discussed in this Report.

5 ACCESSIBILITY, CLIMATE, LOCAL RESOURCES, INFRASTRUCTURE AND PHYSIOGRAPHY

5.1 Accessibility

The Westwood Complex is located on Arthur Doyon Road, 4 km east of the intersection of the Saint-Norbert-de-Mont-Brun Road and Arthur Doyon Road. There are presently two routes leading to this intersection:

- From the south, the intersection is accessible via the paved Provincial No. 117 road which connects Rouyn-Noranda and Val-d'Or, then proceeding for 1 km towards the north via the secondary paved road leading to Saint-Norbert-de-Mont-Brun and the Aiguebelle National Park. This access route is used by light vehicles, is an emergency route, and is controlled by a barrier, when required;
- From the north, the intersection is accessible via the Saint-Norbert-de-Mont-Brun Road, which connects to the paved Provincial No. 117 road and the paved Regional No. 101 road through the municipalities of Saint-Norbert-de-Mont-Brun, Cléricky and D'Alembert. This access is the primary route used for transport and supplies.

The Grand Duc open pit is accessed by the original Arthur Doyon Access road on site which connects the Saint-Norbert-de-Mont-Brun road, to the Doyon office buildings. The Westwood shaft is accessed by a service/haulage road that was built between the headframe and Doyon office building.

The nearest railway line to the Westwood Complex is located about 10 km to the south of the operations. The nearest active airport is the Rouyn-Noranda airport located approximately 25 km east of the Westwood Complex.

The Fayolle property area is accessible via Chemin de la Montagne from Saint-Norbert-de-Mont-Brun. From highway 117, drive 17 km north on Route de Saint-Norbert-de-Mont-Brun up to Saint-Norbert-de-Mont-Brun, then drive 1 km on Route d'Aiguebelle, then drive 12 km north on Rang Abijévis up to the road accessing Fayolle.

There are no major access restrictions for exploration purposes. Typically, access is possible across all of the Project area using pick-up trucks or off road four-wheel drive vehicles.

5.2 Climate

The regional climate varies from dry hot (up to 35°C) in summer (end of June to September) to cold with snowfalls (down to -40°C) in winter (end of December to March).

Mining operations at Westwood and Grand Duc are conducted year-round. Heating is required in winter for the Westwood mine, and to keep ventilation infrastructures and ore bins free of ice.

Exploration activities can be conducted year-round. During the summer months muddy trail conditions can slow surface exploration activities, as the environmental permits require that IAMGOLD avoid releasing suspended materials into water courses.

5.3 Local Resources and Infrastructure

The Abitibi region is an important mining area in Canada and has a number of active mining operations. The largest communities are Rouyn-Noranda and Val d'Or, which are approximately 40 km and 80 km, respectively, from the Westwood Complex. As of the 2021 census, Rouyn-Noranda and Val d'Or have populations of 42,313 and 32,752 inhabitants, respectively. There are many equipment and service suppliers in the general area.

Skilled and experienced workers (miners and technical staff) are readily available. The current workforce primarily comes from Rouyn-Noranda and Val d'Or as well as from the smaller surrounding municipalities.

Additional information on the Project infrastructure is provided in Section 18.

5.4 Physiography

The Westwood Complex is located in glaciated terrain. The topography is relatively flat (<35 m differential elevation) and is approximately 340 m above sea level. Overburden varies from 0–35 m in thickness. There are multiple permanent and intermittent creeks in the Doyon-Westwood property area; however, the clayey soils can remain waterlogged during the summer season. The Westwood Complex area hosts mature forests, including spruce, pine, fir, larch, poplar, birch, and cedars. The Bousquet River cross-cuts the southern border of the Doyon-Westwood property.

Elevations within the Fayolle property range from 290–350 m above sea level. The northern property area has more topographic relief and consequently more outcrop. Two lakes, Matissard and Caste, are present in the eastern property area. A small creek, Ruisseau Paré, occurs in the vicinity of the mined-out

Fayolle open pit. Vegetation consists of a mixture of deciduous and coniferous trees, including ash, birch, spruce, poplar, aspen, pine, and fir.

5.5 Sufficiency of Surface Rights

There is sufficient surface area within the Project boundaries for the open pits, waste rock storage facilities, plant, tailings storage facility, associated infrastructure, and other operational requirements for the life-of-mine (LOM) plan discussed in this Report.

6 HISTORY

6.1 Ownership, Exploration, and Development History

A history of the area is summarized in Table 6-1. This table does not include activities associated with the former Doyon and Mouska mines.

The former Doyon mine, located approximately 2 km west of the current Westwood mine, operated from 1980–2009. Work completed in support of the mining operations included surface and underground drilling, mineral resource and mineral reserve estimates, engineering studies, and mining operations.

The former Mouska mine, situated about 4 km north of the Doyon mine, operated from 1991–2014. Work completed in support of the mining operations included underground drilling, mineral resource and mineral reserve estimates, engineering studies, and mining operations.

A table showing the history for the Fayolle property area is provided in Table 6-2.

6.2 Production History

Production from the Doyon mine from 1980–2009 totalled about 5.3 Moz. Production from the Mouska mine in the period 1991–2014 totalled about 1 Moz. Production from the Fayolle open pit totalled about 13,890 milled ounces.

Table 6-3 summarizes production at the Westwood and Grand Duc mines since commercial production began under IAMGOLD ownership on 1 July, 2014 to 31 December, 2024.

Table 6-1: Doyon-Westwood Property History

Year	Operator	Comment
1910–1950s	Various	Exploration and mine development activities. Major areas included Mooshla-A, Mooshla-B, Westwood, Mic Mac. Excavation of small shaft at Westwood in 1938.
1960–2009	Various, including Silverstack Mines Company Ltd (Silverstack), SOQUEM Inc. (SOQUEM), Long Lac Mineral Exploration Ltd (Long Lac), Cambior Inc. (Cambior), Barrick Gold Corp. (Barrick)	Prospecting, surface and underground core drilling, mineral resource and mineral reserve estimates, engineering studies, and mining operations
		A Cambior surface drilling program in 2004 led to the discovery of the Westwood deposit, located 2 km east of the Doyon mine.
2006–Report effective date	IAMGOLD	<p>IAMGOLD acquired Cambior in 2006.</p> <p>Westwood mine construction commenced in 2008.</p> <p>Refurbishing of the original Doyon mill from 2011–2013.</p> <p>Official production declared in 2014. A seismic event in 2020 temporarily resulted in the mine being placed on care and maintenance. IAMGOLD undertook a comprehensive review of the technical and economic viability of Westwood that included preferred mining methods, mineral processing, and operational practices, with the overall objective of improving economic returns and safe mining practices. Mining operations at Westwood restarted in mid-2021.</p> <p>Open pit mining operations commenced at Grand Duc, where the mineralization being mined is an extension of the historic Doyon mine in October, 2019.</p>

Table 6-2: Fayolle Property History

Year	Operator	Comment
1946–2003	Various, including Destorbelle Mines Ltd, Aiguebelle Goldfields Ltd (Aiguebelle), Hard Rock Gold Mines Ltd, Aldu Mines, Tobruc Cléricy Mines Ltd/Leric Mines Ltd, Victoria Zinc Copper Mines, Alba Exploration Ltd, Rio Canadian Exploration Ltd, Maralgo Mines Ltd, Claims Fayolle, Exploration Noranda, SOQUEM, Copconda Mines, Fontaine International, East Bay Gold Mines, Kerr-Addison Mines, Exploration Aiguebelle, Assayers Limited, Utah Mines Ltd, Ressources Eldor; Exploration Essor, Exploration Fairfield, Orco Resources Inc., Ressources Témisca, Santa Fe Canadian Mining, Ressources Cristobal Inc., Barrick, Ressources Minorca, McWatters Mining	Geological mapping, structural study, outcrop stripping, lithogeochemical sampling, ground geophysical surveys (resistivity, induced polarization (IP), electromagnetic (EM), magnetic), aerial geophysical survey, core drilling, mineral resource estimation. Discovered numerous surface showings and prospects, including Destorbelle, Hard Rock, Fayolle, and Vang.
2003–2019	Typhoon Exploration Inc. (Typhoon; now Goldflare Exploration Inc.)	Acquired property interest. Entered joint venture with Aurizon Mines Ltd (Aurizon) in 2010. Hecla Mining Company (Hecla) acquired Aurizon in 2013; property interest subsequently held by Hecla subsidiary Hecla Quebec Inc (Hecla Quebec). Line cutting, reconnaissance exploration, rock chip, soil, and channel sampling; mobile metal ion geochemical sampling; in-hole IP geophysical surveys; airborne and downhole magnetic geophysical surveys; IP and magnetic geophysical surveys; lithostructural and thin section studies; lithostratigraphic and satellite photo studies; high-resolution topographic survey; metallurgical testwork; Mineral Resource estimation; preliminary mining studies
2019	Monarch Gold Corporation (Monarch)	Acquired property interest from Typhoon and Hecla Quebec. Mineral Resource estimate.
2020–Report effective date	IAMGOLD	Acquired property interest from Monarch. Data reviews, data verification, drilling, metallurgical testwork, Mineral Resource estimate, preliminary mining studies. Mining operations commenced February 2023 and milling operations were completed in June 2024.

Table 6-3: Production History

Parameter	Units	2014	2015	2016	2017	2018
Gold production	000 oz Au	80	60	65	125	129
Tonnes milled	000 t	328	375	347	624	693
Mill grade	g/t Au	7.98	5.26	6.14	6.61	6.11

Parameter	Units	2019 *	2020	2021	2022	2023 #	2024
Gold production	000 oz Au	91	79	35	66	94	134
Tonnes milled	000 t	625	932	965	1,118	1,034	1,107
Mill grade	g/t Au	4.82	2.83	1.24	1.99	3.03	4.04

Note: * Grand Duc production included from November 2019 onward. Production from 2014–2018 is from Westwood. # 2023 production includes production from Fayolle from April 2023 onwards. 2024 production to 31 December 2024.

7 GEOLOGICAL SETTING AND MINERALIZATION

7.1 Regional Geology

7.1.1 Overview

The Project is situated within the Southern Volcanic Zone of the Abitibi sub-province, part of the Archean Superior Province that forms the core of the North American continent. The Abitibi Subprovince is divided into the Southern and Northern Volcanic Zones, which are separated by the Porcupine-Destor-Manneville Fault Zone. A second major fault system, the Cadillac- Larder Lake Fault Zone, separates the Southern Volcanic Zone from the sedimentary rocks of the Pontiac Terrane accretionary prism to the south (Figure 7-1).

The Northern Volcanic Zone consists of basaltic to andesitic and dacitic volcanic rocks, co-magmatic sills, mafic-anorthositic plutonic intrusive rocks, and felsic pyroclastic rocks co-magmatic with tonalitic intrusive plutons. The Southern Volcanic Zone is interpreted to have formed in a series of rift basins that dissected the Northern Volcanic Zone. The Southern Volcanic Zone includes komatiitic to tholeiitic volcanic rocks and large, bimodal, mafic-felsic volcanic centres that have been intruded by granitoid bodies and layered complexes.

The Abitibi sub-province has a prominent east–west structural trend due to regional easterly-trending folds with an axial-planar schistosity. The schistosity displays local variations in strike and dip, which are attributed to either oblique faults cross-cutting the regional trend, or deformation aureoles around resistant plutonic suites. Gold mineralization forms major mineralized deposit clusters within mining districts. Such mining districts include the Doyon-Bousquet-LaRonde mining camp that hosts the Westwood and Grand Duc deposits.

Mineralization styles within the mining districts have been sub-divided into six types:

- Type 1: quartz + carbonate veins found in deformation zones with strong iron carbonate, sericite, and pyrite alteration, characteristic of orogenic deposits;
- Type 2: disseminated sulphides associated with a porphyritic intrusion (subtype 2a = calc-alkaline intrusion; subtype 2b = alkaline intrusion);
- Type 3: epithermal veins with open-space crystallization textures and anomalous concentrations of Zn, Pb and Hg typical of neutral epithermal mineralization;

Figure 7-1: Regional Geology Map

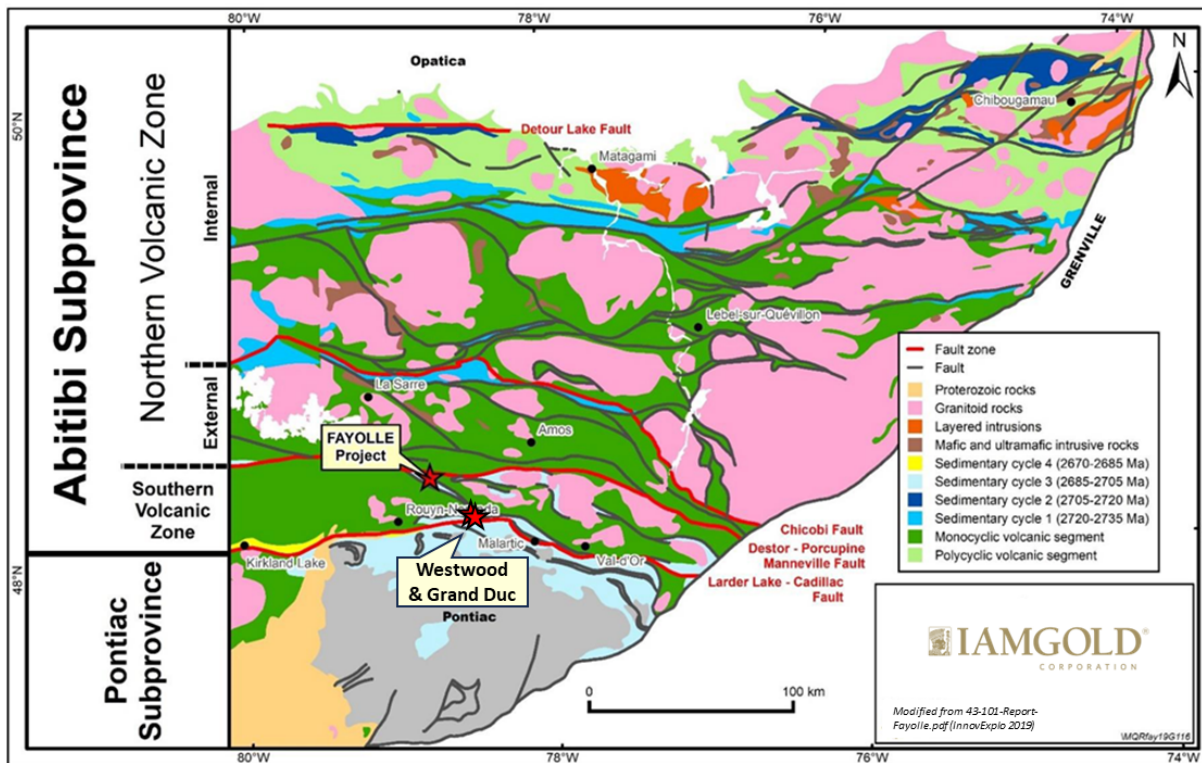

Note: Figure modified by IAMGOLD, 2023, from Modified from Chown et al. (1992) and Daigneault et al. (2002, 2004).

- Type 4: argentiferous quartz-filled extension veins rich in Cu, Sb, Zn and Hg, analogous to Ag-Pb-Zn veins enclosed in clastic metasedimentary rocks;
- Type 5: disseminated sulphides associated with leaching represented by a massive quartz + pyrite (5-10%) residue reminiscent of acidic epithermal deposits;
- Type 6: volcanogenic massive sulphide (VMS) showings associated with quartz + pyrite + chalcopyrite replacement in basaltic flow breccia.

7.1.2 Southern Volcanic Zone

The Southern Volcanic Zone consists of an Archean volcano-sedimentary assemblage divided into three volcanic groups and two sedimentary groups (Table 7-1, Table 7-2). Figure 7-2 shows the zone in the areas of the Doyon-Westwood and Fayolle properties. Figure 7-3 is a legend key to accompany Figure 7-2. Figure 7-4 shows the metallogenic and geological evolution of the assemblage.

Table 7-1: Stratigraphic Table, Doyon-Westwood Property

Doyon–Westwood Property			Intrusive Units	
Group	Unit	Note	Unit	Note
Cadillac Group	Cadillac Group (2687 Ma)	Turbiditic wacke, minor iron formation, and polymictic conglomerate		
Blake River Group	Bousquet Formation (2698 Ma)		Mooshla intrusive complex (co-eval with Bousquet Formation)	Doyon stage = diorites, tonalities, and trondhjemites Mouska stage = gabbros and diorites
	Hébécourt Formation (2701-2706 Ma)	Ferriferous and magnesian tholeiites		
Malartic Group	(2714 Ma)	Ultramafic rocks, andesites and lapilli tuffs		
Kinojevis Group	Lanaudière Formation (2718 Ma)	Basalts, andesites, rhyolites and komatiites		
	Deguisier Formation (2718-2722 Ma)	Ferriferous and magnesian tholeiites		

Table 7-2: Stratigraphic Table, Fayolle Property

Fayolle Property						Intrusive Units
Group	Unit	Note	Unit	Note	Unit	Note
Timiskaming Group	Duparquet Formation (2685–2710 Ma)	Poorly sorted sedimentary rocks deposited in alluvial and fluvial environments.				
Kewagama Group	Mont-Brun Formation (2682–2687 Ma)	Turbiditic sediments			Quartz-feldspar porphyries (c. 2689 Ma)	Andesitic to rhyodacitic composition
	Caste Formation (2691 Ma)	Turbiditic sediments				
Blake River Group	Reneault-Dufresnoy Formation (2702–2696 Ma)	Andesites intercalated with intermediate pyroclastics	Duprat–Montbray Formation (2702 Ma)	Mafic to intermediate volcanics and felsic volcanoclastics		
	Hébécourt Formation (2701–2706 Ma)	Ferriferous and magnesian tholeiites				
Malartic Group	(2714 Ma)	Ultramafic rocks, andesites and lapilli tuffs				
Kinojevis Group	Lanaudière Formation (2718 Ma)	Basalts, andesites, rhyolites and komatiites				
	Deguisier Formation (2718–2722 Ma)	Ferriferous and magnesian tholeiites				

Figure 7-2: Project Area Geology Map

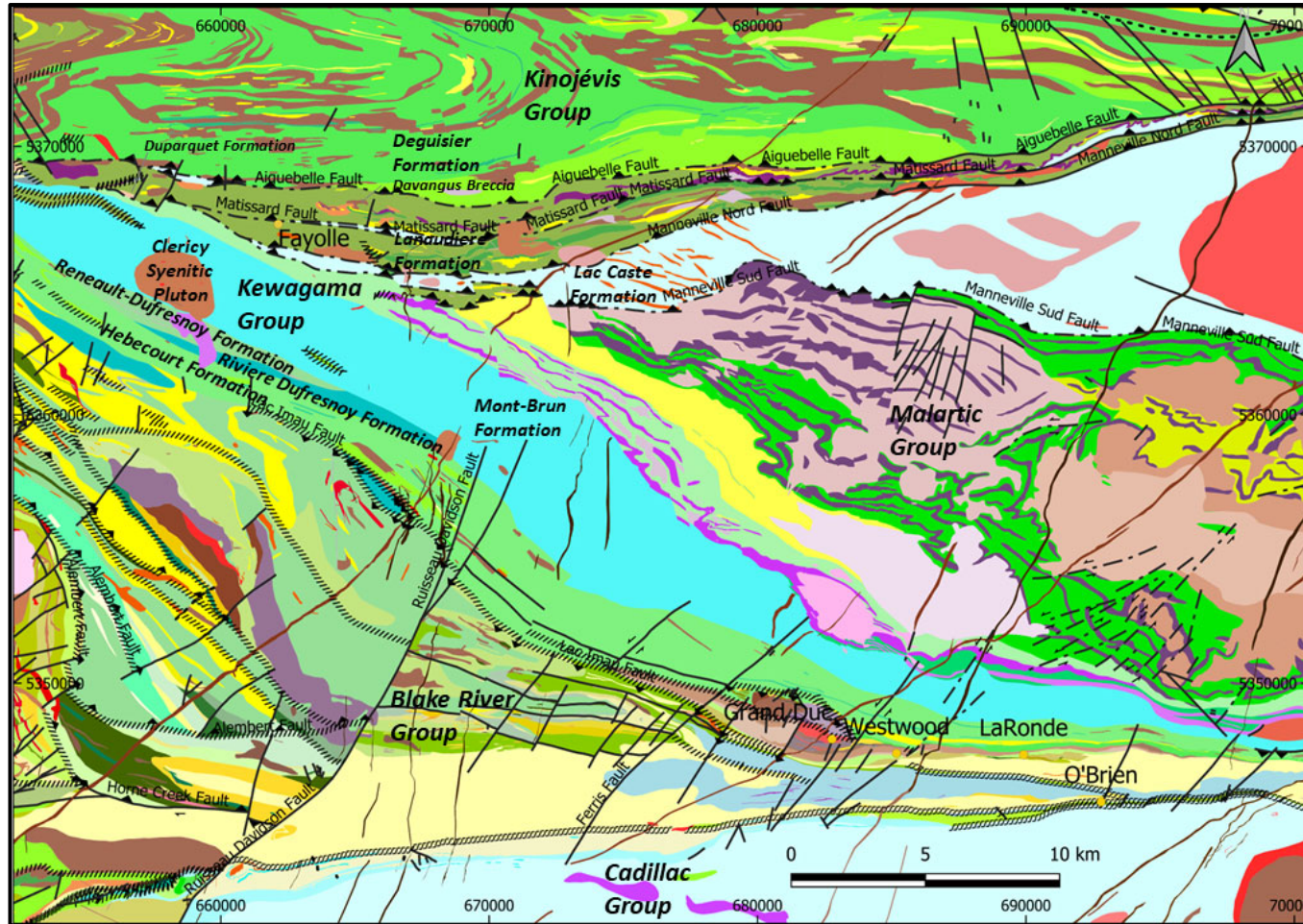



Note: Figure modified by IAMGOLD, 2023, from SIGEOM (UTM17 NAD83)



Figure 7-3: Legend Key to Accompany Figure 7-2

Regional Geology Legend



Proterozoic Diabase Dykes

-  Abitibi Dykes
-  Matachewan Proterozoic Dykes



Intrusive Rocks

-  Clericy Syenitic Pluton
-  Undifferentiated



Mooshla Intrusive Complex

-  Doyon stage: tonalites-trondhjemites (transitional to calc-alkaline)
-  Mouska stage: gabbros-diorites-tonalites (tholeiitic to transitional)



Timiskaming Group

-  Duparquet Formation
-  Davangus Breccia



Kewagama Group

-  Lac Caste Formation
-  Mont-Brun Formation
-  Riviere Dufresnoy Formation

Blake River Group

-  Hebecourt Formation
-  Reneault-Dufresnoy Formation



Bousquet Formation

-  Upper member: intermediate to felsic (transitional to calc-alkaline)
-  Lower member: mafic to felsic (tholeiitic to transitional)
-  Bousquet: felsic sills (tholeiitic to lower member)

Malartic Group

-  Undifferentiated

Kinojévis Group

-  Lanaudiere Formation
-  Deguisier Formation

Note: Figure prepared by IAMGOLD, 2023, modified from Yergeau et al. (2015), Mercier-Langevin et al. (2012), and Carrier and Beausoleil (2019).

Figure 7-4: Geological and Metallogenic Evolution

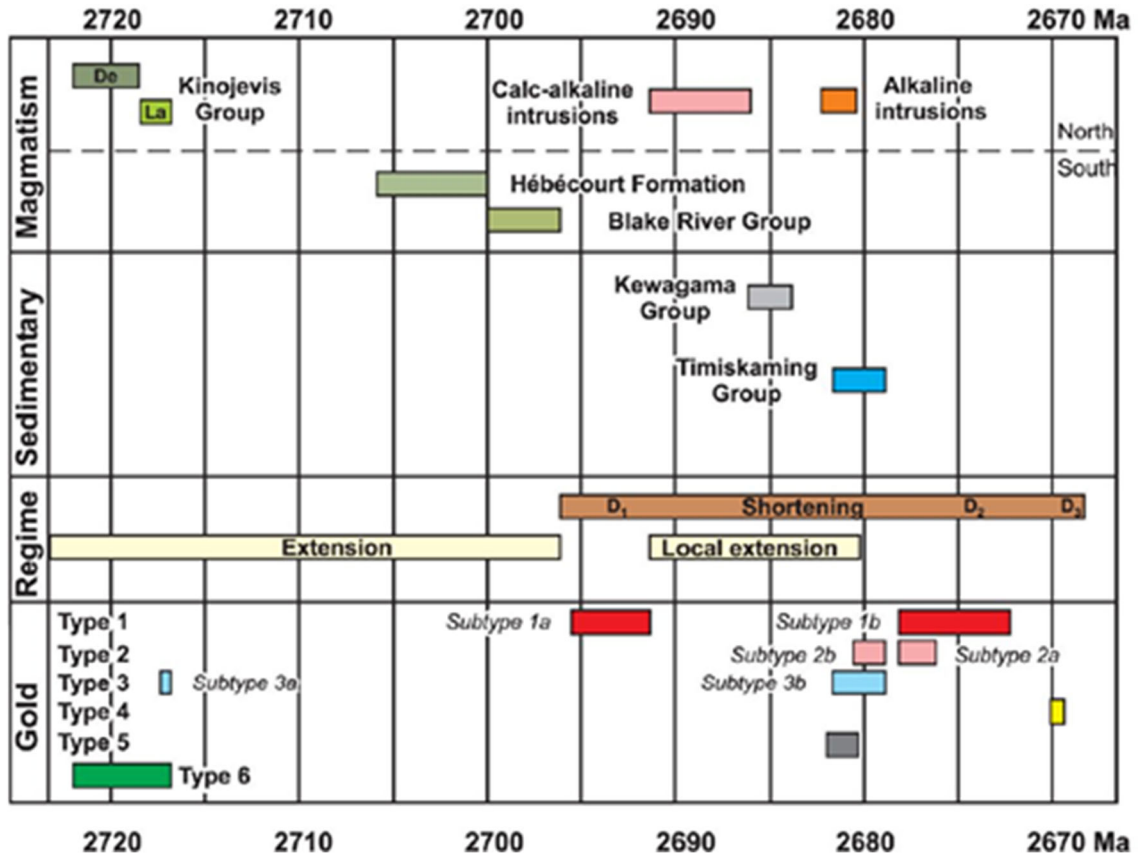

Note: Figure from Legault et al. (2006). De = Deguisier Formation; La = Lanaudière Formation; D1, D2 and D3 = deformation episodes. Gold types summarized in Section 7.1.1.

Rocks have typically been metamorphosed to greenschist to sub-greenschist facies, with amphibolite facies in the vicinity of the intrusive plutons.

Gold mineralization within the Southern Volcanic Zone is hosted in three main deposit types:

- Gold-rich volcanogenic massive sulphide deposits;
- Synvolcanic sulphide veins, stockworks and disseminations;
- Intrusion-hosted sulphide-rich quartz veins and orogenic sulphide-rich gold–copper veins.

7.2 Local Geology

7.2.1 Doyon-Westwood Property

7.2.1.1 Lithologies

The Doyon-Westwood property is underlain by massive to pillowed, mafic and tholeiitic volcanic rocks of the Hebecourt Formation (Lower Blake River assemblage), see Figure 7-5. This is overlain by the Bousquet Formation that is subdivided into two geochemically distinct lower and upper assemblages. The lower assemblage includes a basal basaltic to andesitic scoriaceous tuff, overlain by massive to fragmental felsic, tholeiitic-affinity volcanic rocks, followed by a succession of massive to pillowed mafic, intermediate, and tholeiitic to transitional flows.

The upper assemblage consists of transitional to felsic volcanic and shallow intrusive rocks that form flows, lobes, flow-breccia, and sill complexes. Gold mineralization in the Westwood deposit area is typically hosted in the upper assemblage of the Bousquet Formation.

To the north of the volcanic units are sedimentary rocks of the Kewagama Group, and to the south, Cadillac Group sedimentary rocks.

The Mooshla Intrusive Complex, a polyphase syn-volcanic pluton, is comagmatic with the Bousquet Formation and intrudes the volcanic rocks in the western part of the property. The latest stage of the Mooshla Intrusive Complex, consisting of plagioclases-amphibole porphyry dykes and sills, plagioclase-quartz porphyry, and aphyric and phenocrystalline quartz trondhjemite, hosts the mineralization at the Grand Duc deposit. The trondhjemite is typically massive, homogeneous, and competent, but can contain up to 15% miarolitic cavities filled with chlorite, amphibole, epidote, quartz, and/or pyrite.

Figure 7-5: Geology Map, Doyon-Westwood Property

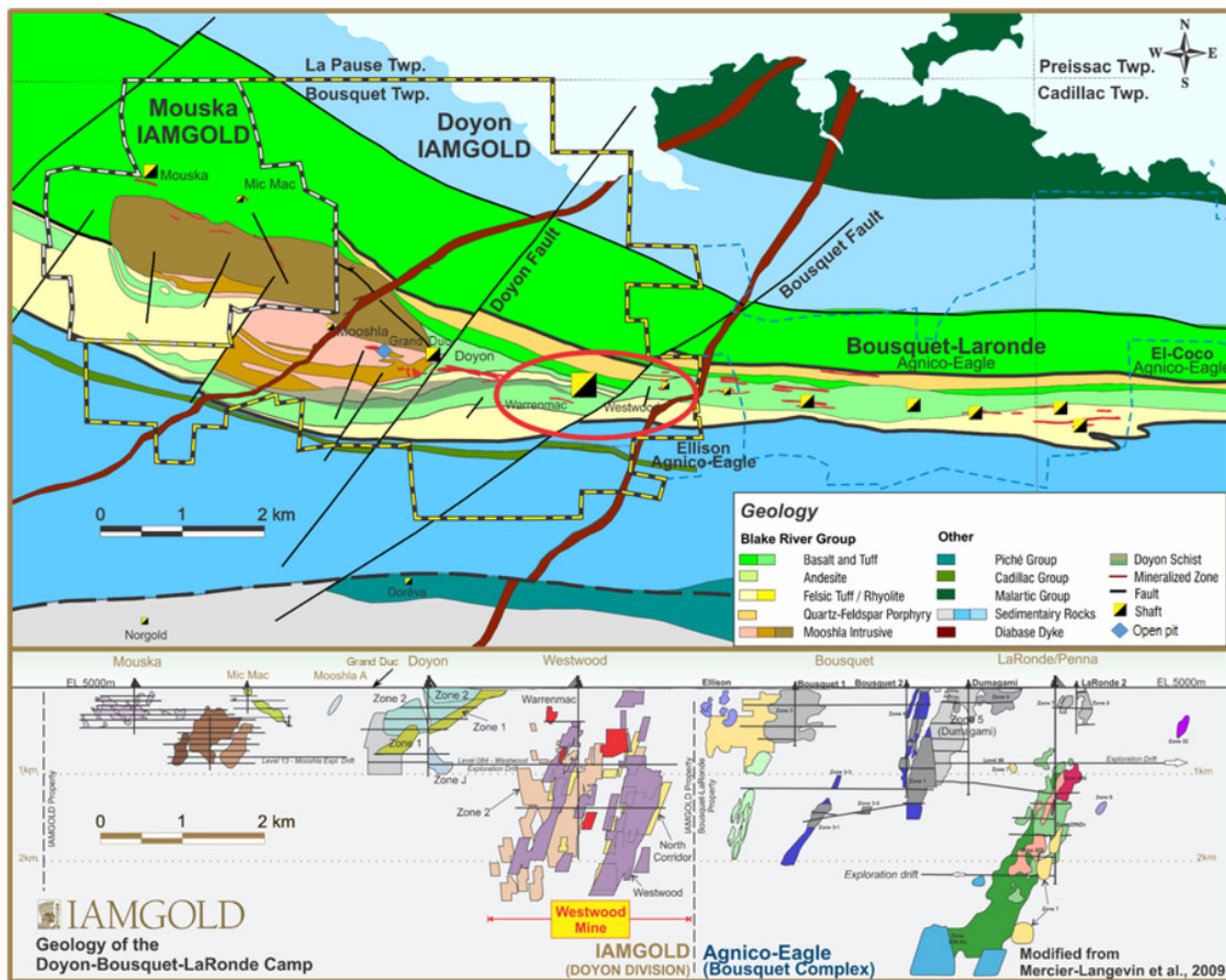

Note: Figure prepared by IAMGOLD, 2022, modified from Mercier-Langevin et al., 2009.

7.2.1.2 Structure

All of the lithologies within the Doyon-Bousquet-LaRonde mining camp have been influenced by a north-south compression event, which resulted in a subvertical to steeply south dipping east-west (F2) penetrative schistosity. High-strain anastomosing east-west corridors are observed throughout the property, mainly at the geological contacts and within highly altered zones. These east-west structures have a significant influence on infrastructure stability at the Westwood Mine, including seismicity and drive closures.

Late sub-vertical conjugated brittle faults (northeast to southwest and northwest to southeast) and joints occur throughout the property area. Globally, these structures contribute to seismicity at depth in the Westwood mining operations.

The trondhjemite intrusive unit is little deformed by the main foliation that systematically affects the volcanic rocks of the Doyon-Bousquet-LaRonde mining camp.

7.2.1.3 Metamorphism

Lithologies within the property area are typically metamorphosed to the upper greenschist/lower amphibolite facies.

The regional metamorphism grade is transitional from upper greenschist in the upper part of the Westwood deposit to lower amphibolite facies in the lower part of the deposit (> 1,500 m depth).

7.2.1.4 Mineralization

Mineralization in the Westwood area forms three easterly-trending, strongly deformed (D2 flattening and stretching), steeply south-dipping corridors that are stacked from north to south: the Zone 2 Extension, North, and Westwood Corridors. Mineralization styles include gold-bearing VMS-type lenses, quartz veins, and disseminated sulphide zones.

Mineralization at Grand Duc is associated with a miarolitic facies within the trondhjemite.

7.2.1.5 Alteration

The alteration types within the three easterly-trending mineralization corridors are subdivided into distal and proximal alteration. Distal alteration typically consists of an assemblage of chlorite, biotite, carbonate, amphibole ± garnet and sericite. Proximal alteration typically consists of quartz, sericite, and pyrite, with, depending on the corridor, lesser albite, gypsum, garnet, chlorite, biotite, and calcite.

An aluminous alteration assemblage composed of zinc-rich staurolite, magnetite, kyanite, and andalusite with quartz, sericite, and pyrite can be replacing these typical alteration assemblages at depth (> 1,500 m) to the east of the Bousquet Fault within the Westwood and North Corridors.

7.2.2 Fayolle Property

7.2.2.1 Lithologies

The northern part of the Fayolle property is underlain primarily by the Lanaudière Formation (Figure 7-6), the uppermost unit of the Kinojevis Group, consisting of basalt layers intercalated with felsic and ultramafic rocks. A wedge of the Lac Caste Formation of the Kewagama Group is in faulted contact with the Lanaudière Formation along the north and south sides of the Manneville North Fault. The Lac Caste Formation comprises bands of turbiditic sedimentary rocks, consisting of beds of sandstone and mudrock with black siliceous argillic horizons. The polygenic Davangus Breccia, part of the Duparquet Formation of the Timiskaming Group, forms an unconformity with the surrounding older volcanic rocks of the Lanaudière Formation.

The central portion of the Fayolle property is underlain, from north to south, by the Lac Caste Formation and ultramafic flows, andesite and intrusions of the Malartic Group. The Manneville South Fault separates these units from the Lanaudière Formation to the north.

The southernmost and westernmost ends of the Fayolle property are underlain by the Mont-Brun Formation, which represents a central band of turbiditic sediments within the Kewagama Group. The southeast-trending La Pause Fault forms the contact between the Mont-Brun Formation and the volcanic units of the Malartic Group.

Intrusive felsic dykes are located in a zone of imbrication between the Aiguebelle Fault to the north of the Fayolle Property and the La Pause Fault at its southern end.

Gold mineralization is hosted in porphyritic dykes of intermediate composition and in volcanic rocks.

7.2.2.2 Structure

The Fayolle property covers a structural imbrication zone involving the Manneville North, Manneville South and La Pause faults along a strike length of more than 3 km. This zone of imbrication is generally considered to be part of the Porcupine-Destor-Manneville Fault Zone, where it splits into several secondary faults. However, there is an alternate interpretation whereby the faults in this sector are superimposed and converge in the west to form the Porcupine-Destor Fault (Goutier, 1997), and are not subsidiary to that fault.

In either interpretation, the faults are associated with either the D1 event (refer to Figure 7-6) or with the opening of the Duparquet Basin.

Figure 7-6: Fayolle Property Geology Map

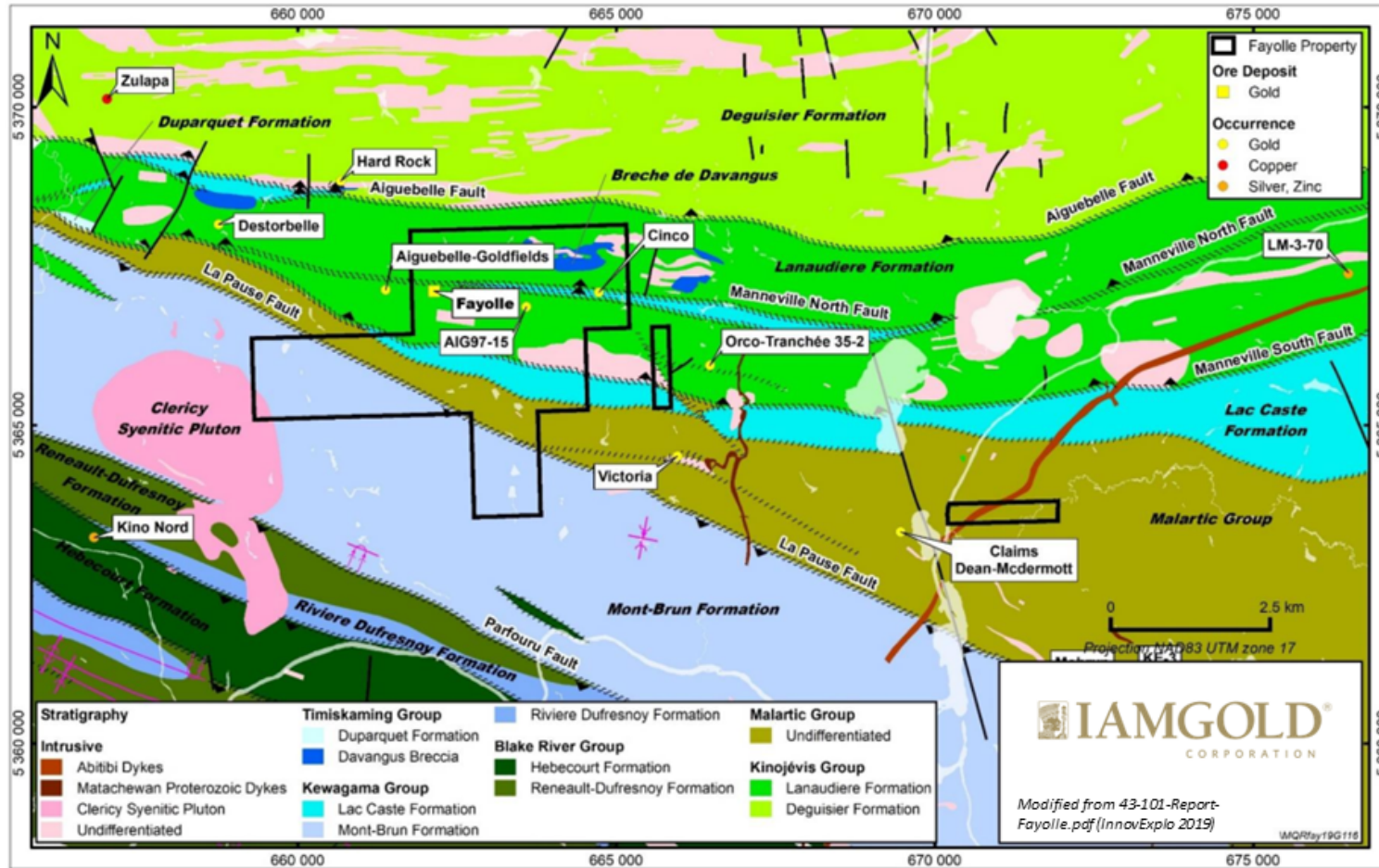

Note: Figure prepared by IAMGOLD, 2023, modified from Carrier and Beausoleil (2019).

7.2.2.3 Metamorphism

Lithologies within the property area are typically metamorphosed to the upper greenschist/lower amphibolite facies.

The regional metamorphism grade is transitional from upper greenschist in the upper part of the Westwood deposit to lower amphibolite facies in the lower part of the deposit (>1,500 m depth).

7.2.2.4 Mineralization

Mineralization is characterized by 1–5% disseminated pyrite that is spatially associated with, or contained within, veinlets of quartz and/or carbonate minerals.

7.2.2.5 Alteration

Major alteration styles include carbonatization, with calcite as the distal phase and ankerite in the core of the gold mineralization, fuchsite, silicification, and albitization.

Magnetism decreases upon approaching the mineralized zone, likely caused by leaching of magnetite in the volcanic rocks. The volcanics and intermediate dykes are weakly to moderately hematized.

7.3 Deposits

7.3.1 Westwood

7.3.1.1 Dimensions

The Westwood deposit is approximately 1.9 km long by 500 m wide, generally trending east–west and dipping steeply south. Mineralization has an average thickness of 1.7 m. The deposit has been drill tested to an approximate 2.5 km depth. It remains open at depth and to the west.

7.3.1.2 Lithologies

The main lithologies in the Westwood Mine area are summarized in Table 7-3. Figure 7-7 is a cross-section through the mineralized corridors showing a simplified geological interpretation. Figure 7-8 shows more geological detail in a cross-section through the Zone 2 Extension area.

Table 7-3: Westwood Mine Lithologies

Unit	Sub-units	Mine Subdivision	Description	Note
Tholeiitic sills and dykes		5.1.3, 5.4.0	Andesitic to basaltic tholeiitic sills and dykes	Mostly located in the immediate hanging wall and footwall of the Westwood and North Corridors' ore zones. Acted as cap rocks as well as reactive sinks for base metals and gold.
Felsic dykes		5.3.1, 5.3.2	Felsic to mafic sills, dykes, and cryptodomes. Subunit #5.3a represents a series of metric rhyolitic quartz- and feldspar-phyric dykes and sills that intrude the felsic volcanic rocks. Subunit #5.3a-(b) is a thick feldspar-phyric calc-alkaline rhyolitic cryptodome found in the upper and eastern parts of the Westwood Mine.	These dykes and sills are mainly recognized in the vicinity of the Westwood Corridor, and they locally act as impermeable cap rocks that help focus the auriferous hydrothermal fluids (Yergeau et al., in prep.). Subunit #5.3a-(b) lies in the hanging wall of the Westwood Corridor and is thus poorly altered and not related to any ore zone.
Bousquet Formation	Upper assemblage	5.5.1, 5.5.2 and 5.5.3	calc-alkaline rhyodacitic to rhyolitic dome-breccia complexes that are poorly altered, generally feldspar-phyric, and rich in biotite porphyroblasts.	It is in contact with the metasediments of the Cadillac Group to the south, with a level of semi-massive to massive barren pyrrhotite overlain by black shale, which generally lies at the contact.
		5.2.1	Calc-alkaline to transitional rhyodacitic unit that is located in the immediate hanging wall of the Westwood Corridor ore zones and is composed mainly of volcanic breccias and feldspar-phyric massive lobes and domes	
		5.1.4, 5.4.5	Dacitic lapilli to blocky tuffs with feldspar phenocrysts, when poorly altered. This subunit has a transitional to calc-alkaline affinity. Represents the footwall of the Westwood Corridor	

Unit	Sub-units	Mine Subdivision	Description	Note
	Lower assemblage	5.1.1, 5.1.2	Basaltic to andesitic massive lavas and associated volcanoclastic rocks of transitional affinity. Those rocks contain centimetric amygdules filled with quartz and carbonate.	Host the North Corridor ore zones
		4.4.0, 4.1.1.	Mafic to intermediate tuffs, volcanic breccias and lavas	Host parts of the Westwood Zone 2 Extension
		4.3.0	Transitional in affinity and dacitic to rhyolitic in composition Affected by an intense sericite alteration (i.e., sericite schist) zone, which pinches at depth and eastward from the Doyon Mine area	Hosts most of the Westwood Zone 2 Extension ore zones
		4.2.0	Tholeiitic to transitional affinity and felsic to intermediate composition	
		3.3.0, 3.3.1	Tholeiitic to transitional and mafic to intermediate volcanic rocks displaying tuffaceous, breccia, and flow textures that are interpreted as submarine high-density flow deposits.	Hosts minor parts of Westwood Zone 2 Extension.
		2	Tholeiitic quartz- and feldspar-phyric felsic rocks of intrusive origin (but initially interpreted as tuffs).	
Hebecourt Formation		1	Tholeiitic basalt with pillowed, brecciated, and massive flow textures with local glomeroporphyritic horizons. Numerous gabbroic sills and rare narrow fine tuff beds.	

Figure 7-7: Geological Map – Plan View of Level 132-00

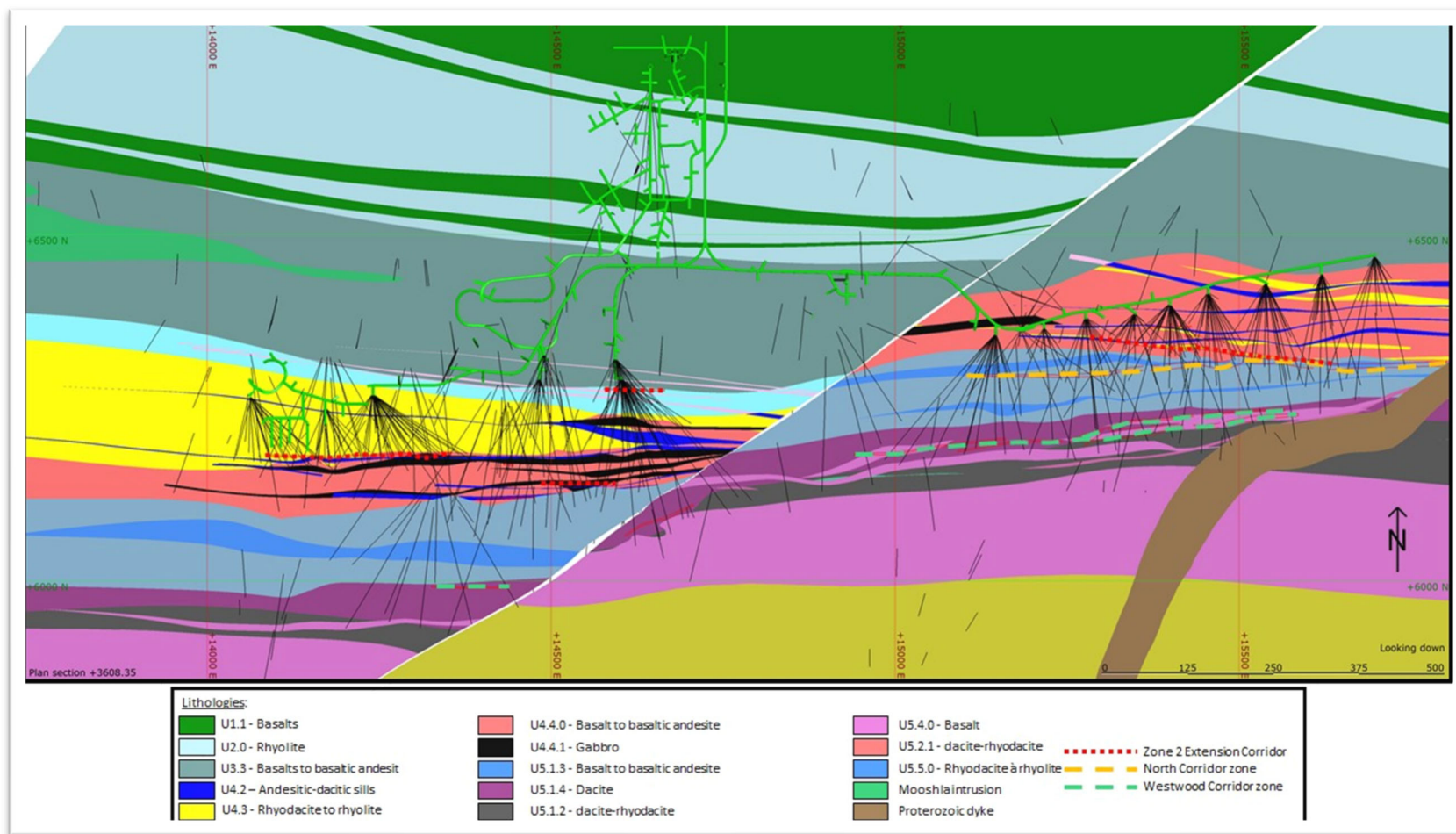

Note: Figure prepared by IAMGOLD, 2023.

Figure 7-8: Westwood Deposit Central Cross-Section

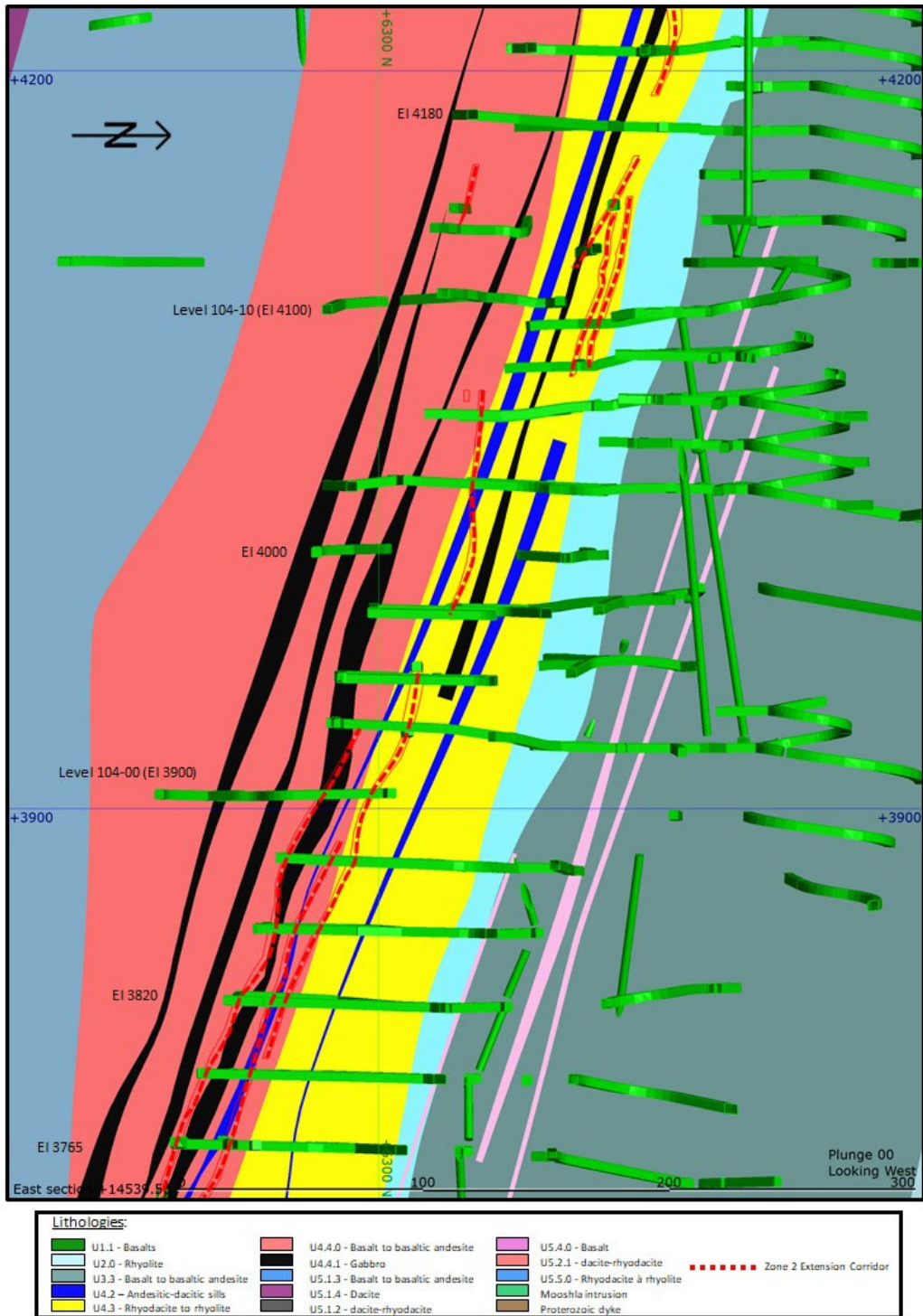

Note: Figure prepared by IAMGOLD, 2023. Section 14,540 m E, looking west. Section is within the Bousquet Formation Lower Member.

The North and Westwood corridors are spatially and genetically associated with the calcalkaline, intermediate to felsic volcanic rocks of the upper Bousquet Formation. The formation of the disseminated to semi-massive ore zones is interpreted as strongly controlled by the replacement of porous volcanoclastic rocks at the contact with more impermeable massive cap rocks that helped confine the upflow of mineralizing fluids. The massive sulfide lenses are spatially associated with dacitic to rhyolitic domes and are interpreted as being formed, at least in part, on the paleo-seafloor.

The epizonal, sulfide-quartz vein-type ore zones of the Zone 2 Extension are associated with the injection of subvolcanic, calc-alkaline felsic sills and dikes within the lower Bousquet Formation. These subvolcanic intrusive rocks are cogenetic and coeval with the intermediate to felsic lava flows and domes of the upper Bousquet Formation.

7.3.1.3 Structure

Figure 7-9 shows the major faults and shears that are currently modelled.

7.3.1.4 Mineralization

The mineralization styles within each corridor are summarized in Table 7-4.

Drill sections through each of the Zone 2 Extension, North and Westwood Corridor deposit areas are provided in Figure 7-10, Figure 7-11, and Figure 7-12, respectively.

7.3.1.5 Alteration

The alteration styles within each corridor were included in Table 7-4. Alteration types are frequently spatially associated with the major faults.

Figure 7-9: Key Structural Features, Westwood

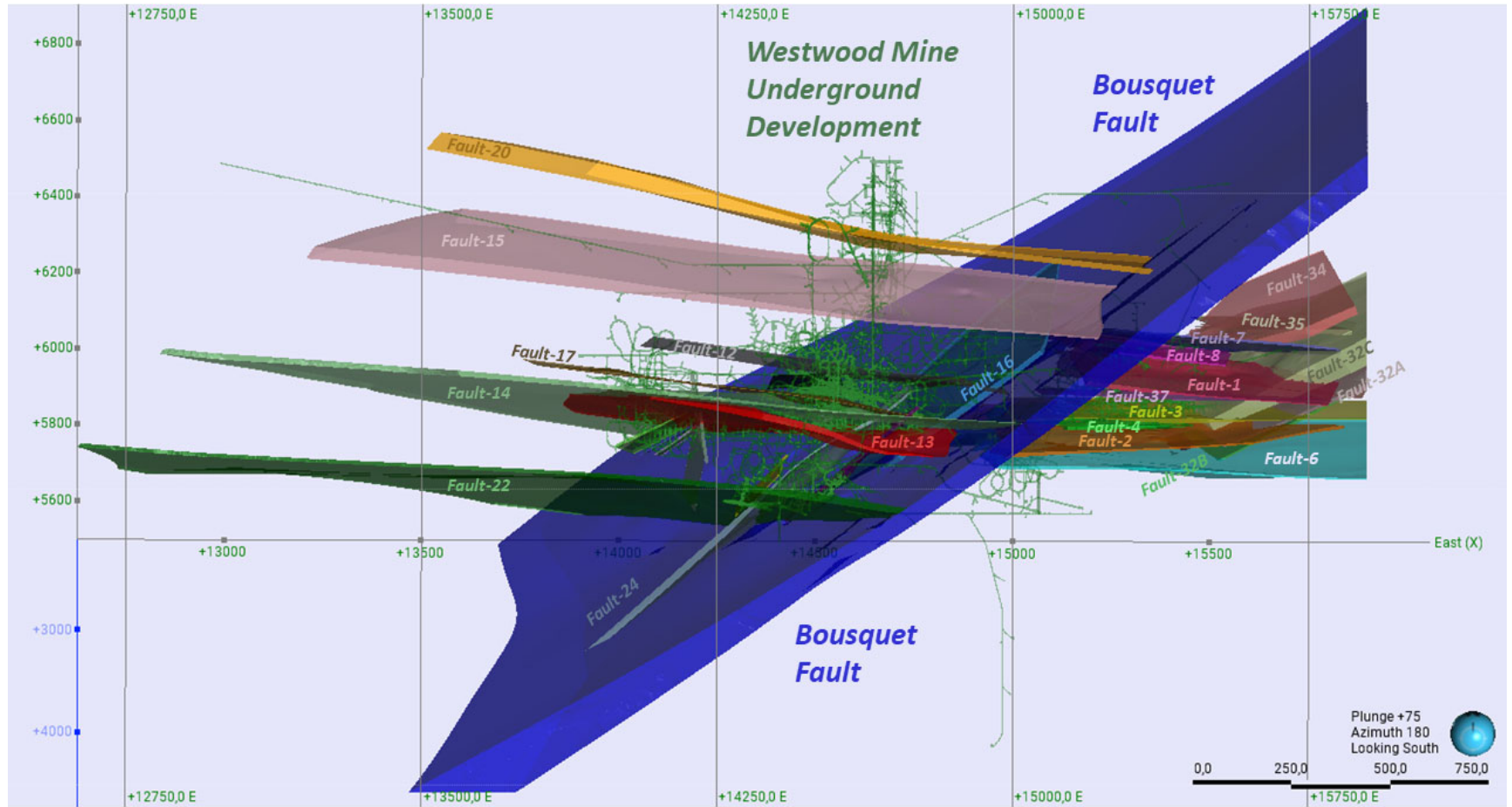

Note: Figure prepared by IAMGOLD, 2023. Isometric 3D view looking down, dipping steeply southward.

Table 7-4: Mineralized Corridors

Corridor	Host Lithologies	Alteration	Mineralization Style	Notes
Zone 2 Extension	Felsic and mafic volcanics	Distal: chlorite–biotite–carbonate–amphibole ± garnet–sericite Footwall and hanging wall proximal: quartz–pyrite–sericite–albite ± gypsum	<15 cm thick quartz-pyrite veins and veinlets with variable but usually minor amounts of chalcopyrite and rare sphalerite. Remobilized free gold is frequently observed in the host rocks	The vein system is roughly oriented N85° to 105° with a dip varying between 60° to 70°S, and is slightly discordant to the regional foliation and S0 planes (direction and dip). The majority of ore shoots are parallel to the stretching lineation that plunges at ± 80° south-west on the main foliation plane but a minority of them are perpendicular to the stretching lineation.
North	Mafic to intermediate volcanic rocks	Distal: chlorite–biotite–carbonate–amphibole ± garnet–sericite Proximal: quartz–sericite–pyrite ± garnet–chlorite–biotite–calcite	Centimetre to decimetre quartz-pyrite veins and concentrations with locally abundant sphalerite–chalcopyrite ± pyrrhotite–galena.	Generally parallel to the Zone 2 Extension with a dip ranging from 70° to 80°S and is weakly discordant to the regional foliation
Westwood	Intermediate to felsic volcanic rocks	Distal: chlorite–biotite–carbonate–amphibole ± garnet–sericite	Pyrite-sphalerite-chalcopyrite-pyrrhotite ± galena veins, stringers, and massive sulphides associated with variable amounts of quartz and rare visible gold. These mineralized zones are a few centimetres to more than 50 cm thick in a disseminated pyrite halo and in some places reach thicknesses of up to 10 m. Local massive to semi-	The corridor is generally parallel to the Zone 2 Extension and North Corridor with dips ranging from 70° to 80°S. Likely to be associated with a gold-rich VMS-type hydrothermal system.

Corridor	Host Lithologies	Alteration	Mineralization Style	Notes
		Proximal: quartz-sericite- pyrite	massive sulphide lenses ranging from 1 m to 14 m are also present within the corridor. Gold remobilization into syn-deformation, spatially related to the mineralized zones, black quartz veins with chalcopyrite traces is common, but not systematically found along both sides of the massive sulphide lens.	

Figure 7-10: Cross-Section Showing Mineralization, Zone 2 Extension

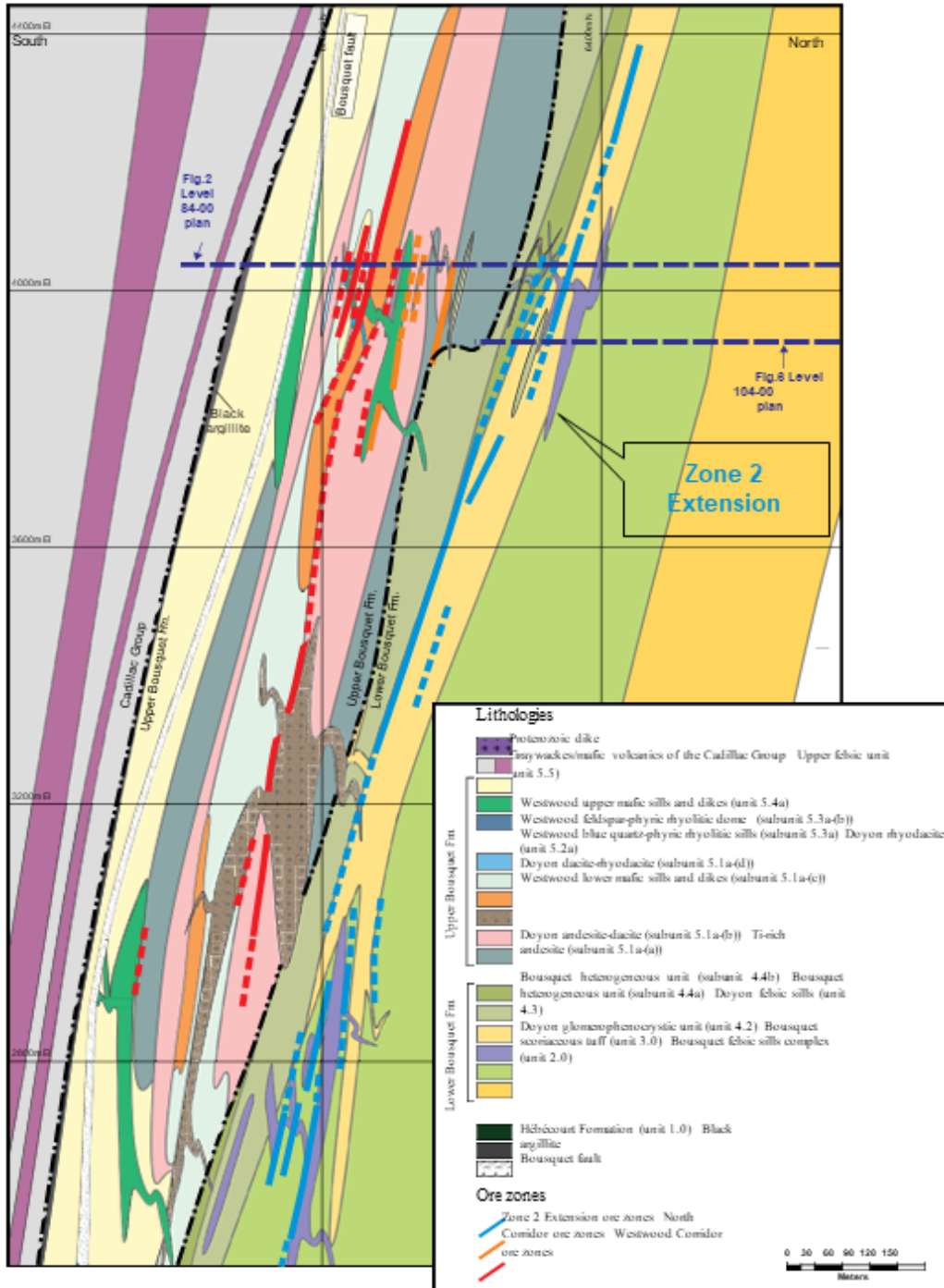

Note: Figure from Yergeau et al., (2022).

Figure 7-11: Cross-Section Showing Mineralization, North Corridor

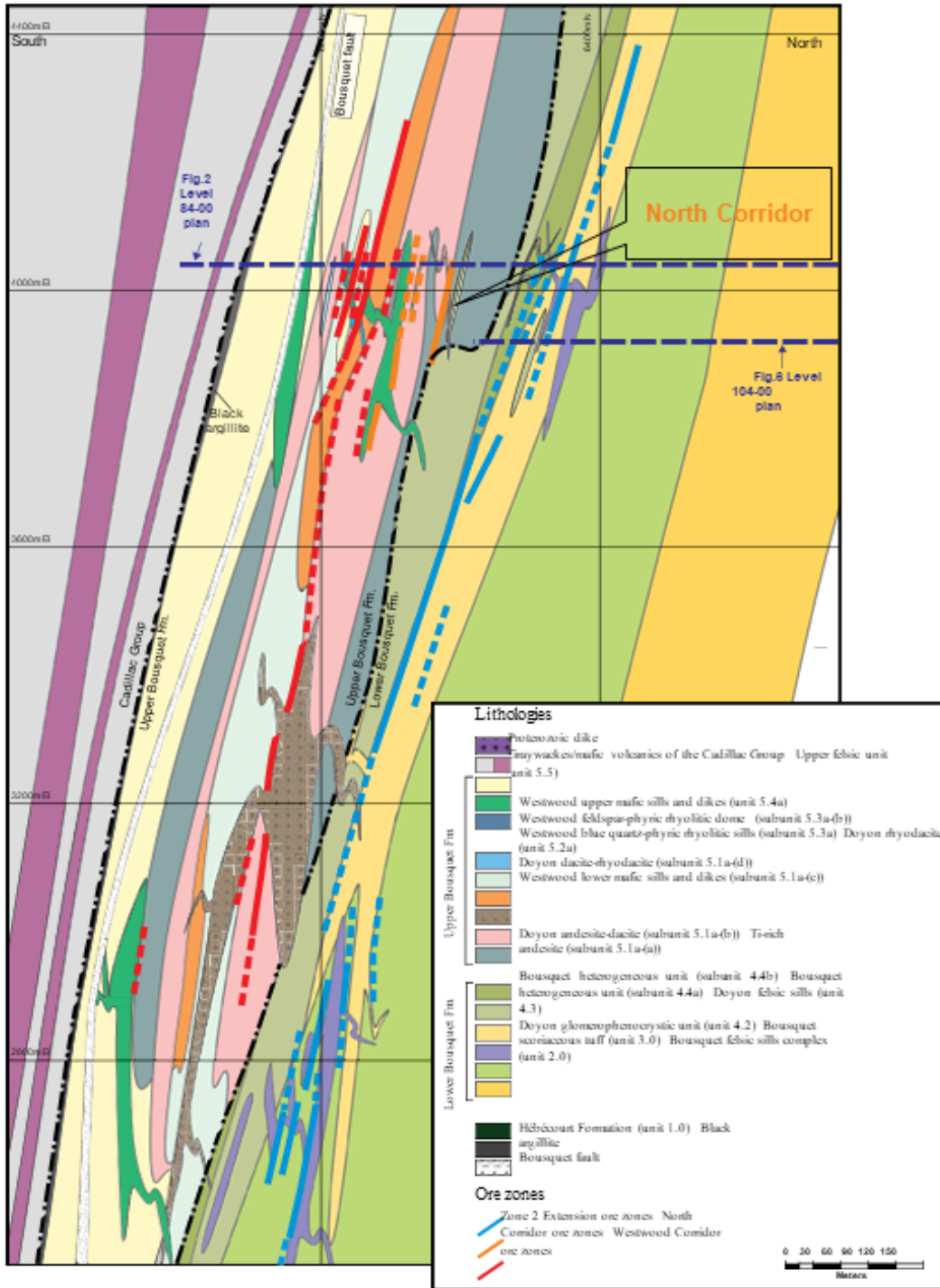

Note: Figure from Yergeau et al., (2022).

Figure 7-12: Cross-Section Showing Mineralization, Westwood Corridor

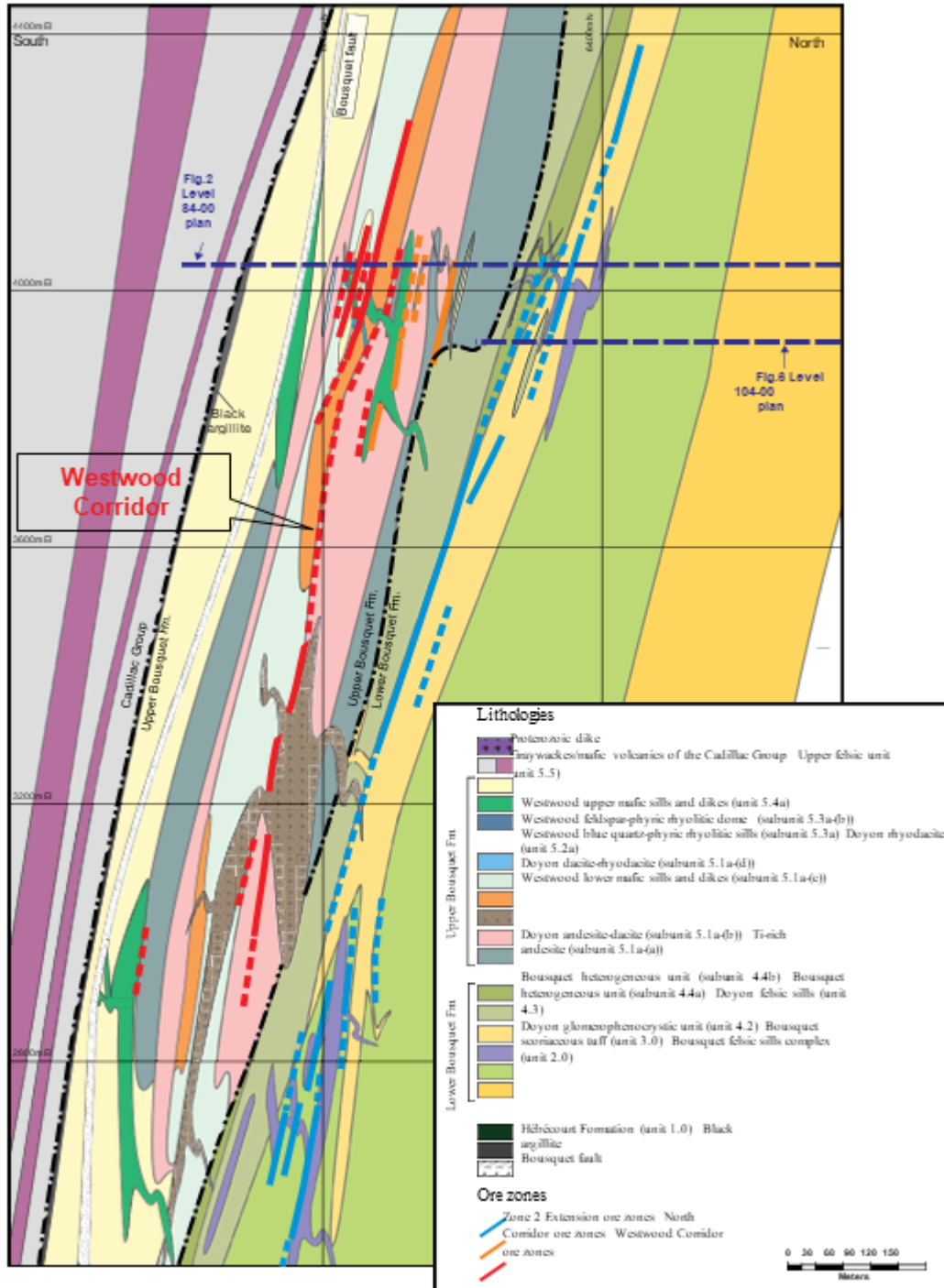

Note: Figure from Yergeau et al., (2022).

7.3.2 Grand Duc

7.3.2.1 Dimensions

The deposit is about 620 m long in the east–west direction, by 300 m wide, based on the most recent block model. Mineralization has an average thickness of 30 m. The deposit has been drill tested to 250 m depth. It remains open to the east and west.

7.3.2.1 Lithologies

In the western part of the Doyon-Westwood property, units 3.0, 4.2, and 4.3 of the Bousquet Formation are intruded by the polyphase syn-volcanic Mooshla Intrusive Complex. The key lithologies within this unit are summarized in Table 7-5. A geological map for the deposit area is provided in Figure 7-13, and an accompanying legend key in Figure 7-14.

7.3.2.1 Structure

The Mooshla Intrusive Complex has been subjected to at least three deformation phases (Savoie et al., 1991; Langshur, 1990; Belkabar and Hubert, 1995). The D1 deformation phase is represented by a slight northeast–southwest trending, moderately inclined foliation. The D2 phase is defined by an intense east–west-oriented penetrating fabric and by shears and faults whose lineations plunge sharply to the south. The D2 deformation events are superimposed by D3 transpressional right-lateral dextral faults and by a potential D4, that may be represented by left-lateral sinistral brittle faults.

7.3.2.2 Mineralization

The mineralization styles within the Grand Duc deposit are summarized in Table 7-6.

Figure 7-15, Figure 7-16, and Figure 7-17 are a selection of plan and section views through the Grand Duc deposit. Figure 7-16 shows the orientation of the drilling to the mineralization.

7.3.2.3 Alteration

Alteration types affecting the Mooshla Intrusive Complex in the Grand Duc sector include chlorite, sericite, carbonate, pyrite, and silica. Locally the rock is highly sericitized, especially near the wallrock to the mineralized veins and along shear corridors.

Table 7-5: Phases, Mooshla Intrusive Complex

Stage	Description	Note
Late (Doyon stage)	Diorites, tonalities, and trondhjemites	Coeval with the Bousquet Formation upper assemblage. Hosted Doyon Mine's West Zone and hosts the Grand Duc open pit
Early (Mouska stage)	Gabbros and diorites	Coeval with the Bousquet Formation lower assemblage. Hosted the mined-out Mouska deposit.

Figure 7-13: Geology Map, Grand Duc Area

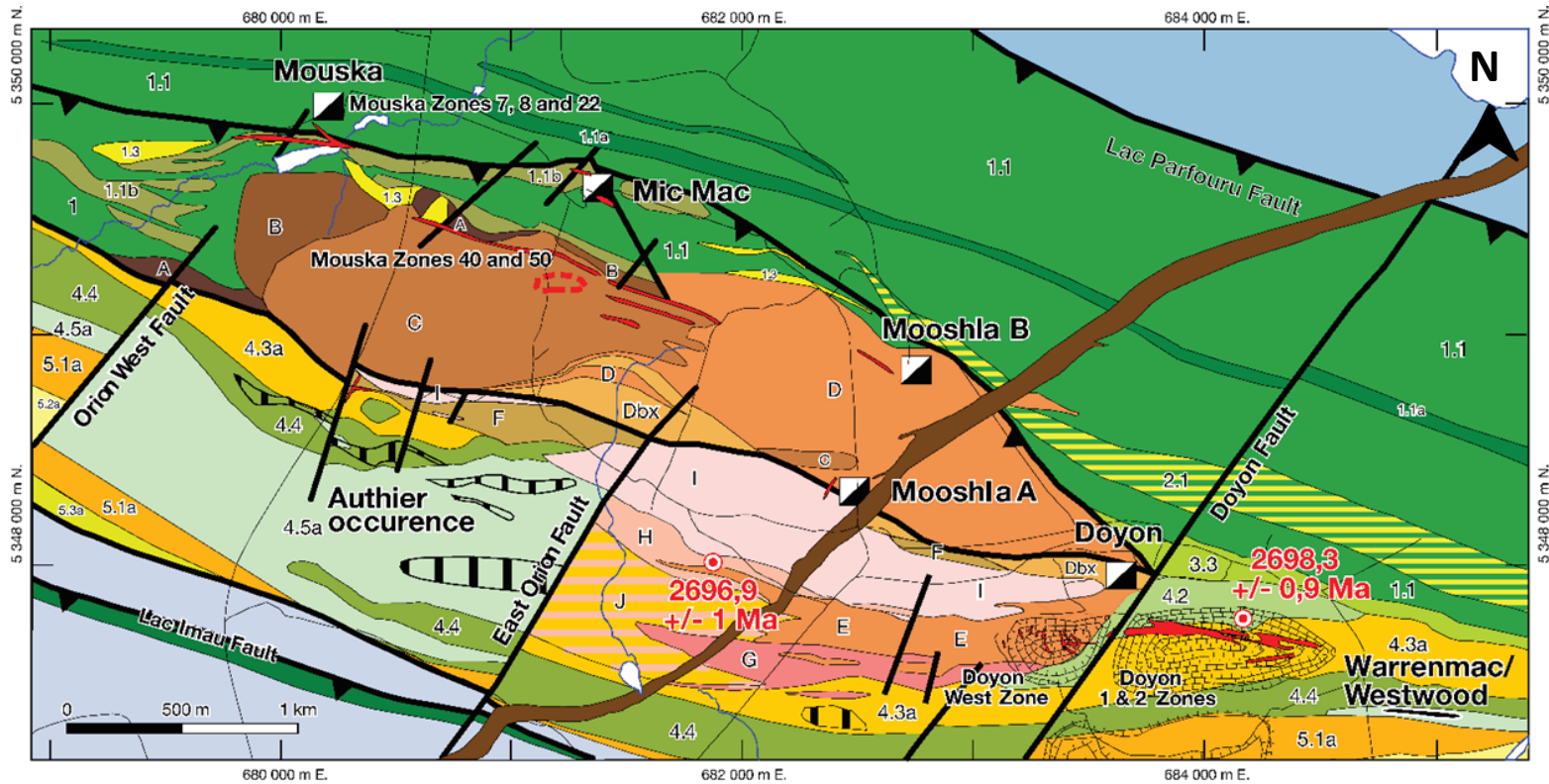

Note: Figure modified by IAMGOLD, 2023, after Galley et al., (2014).

Figure 7-14: Legend Key to Accompany Figure 7-13

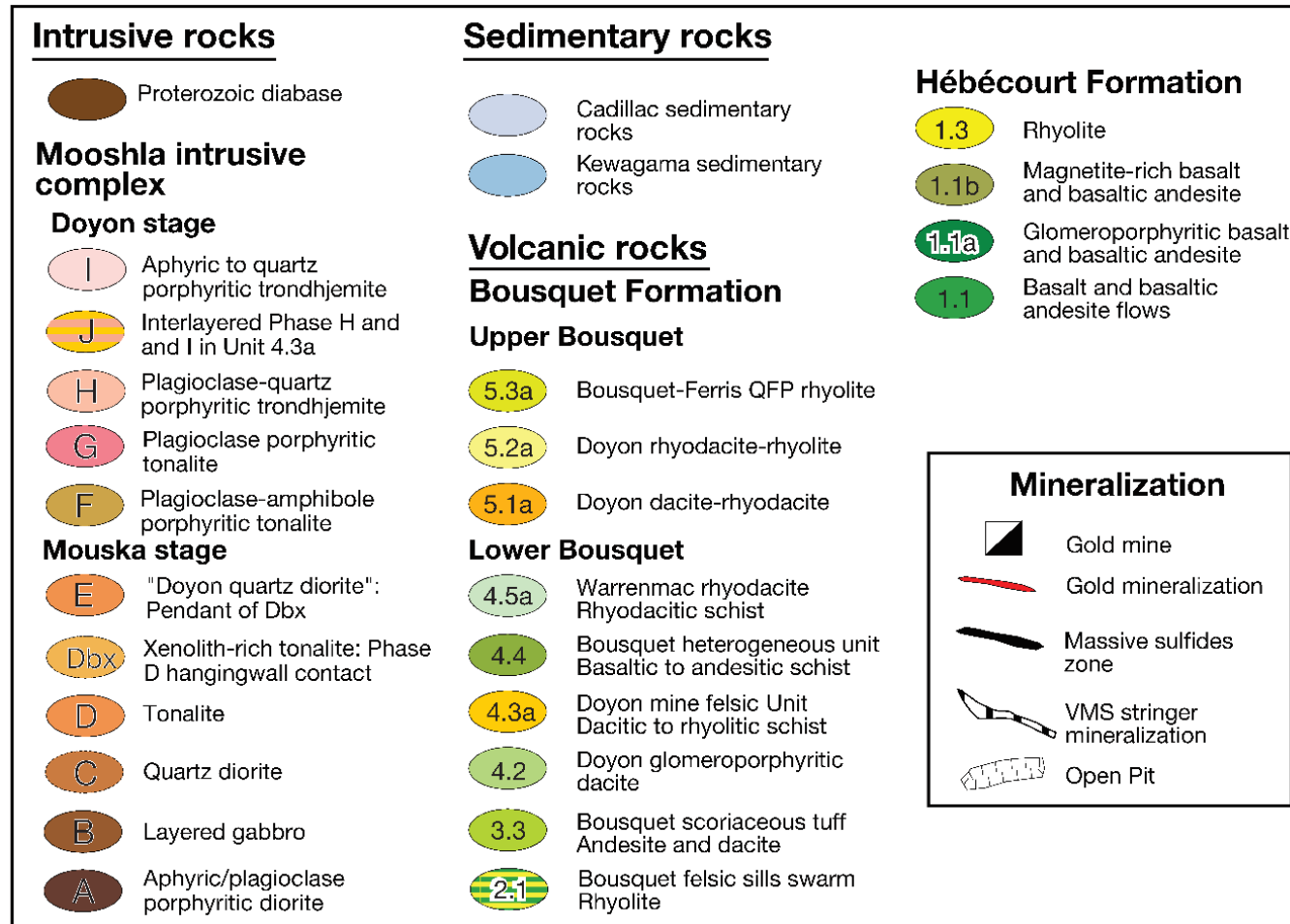

Note: Figure prepared by IAMGOLD, 2023

Table 7-6: Grand Duc Mineralization

Host Lithologies	Mineralization Style	Notes
Miarolitic facies within trondhjemite	<p>Quartz-pyrite-chalcopyrite high-grade remobilization veins.</p> <p>Gold mineralization occurs as either disseminated pyrite in shears zone, quartz-pyrite-carbonate-chlorite veins, and veinlets, as fill in fractures, or in centimetric pyritic band parallel to foliation.</p> <p>Gold grades are higher in the presence of coarse pyrite</p>	<p>Main corridor oriented N105° to N110° and south dipping (from 50° to 70°).</p> <p>Lesser series of veins and fractures oriented N175° and N045°</p>

Figure 7-15: Mineralization Plan View, Grand Duc

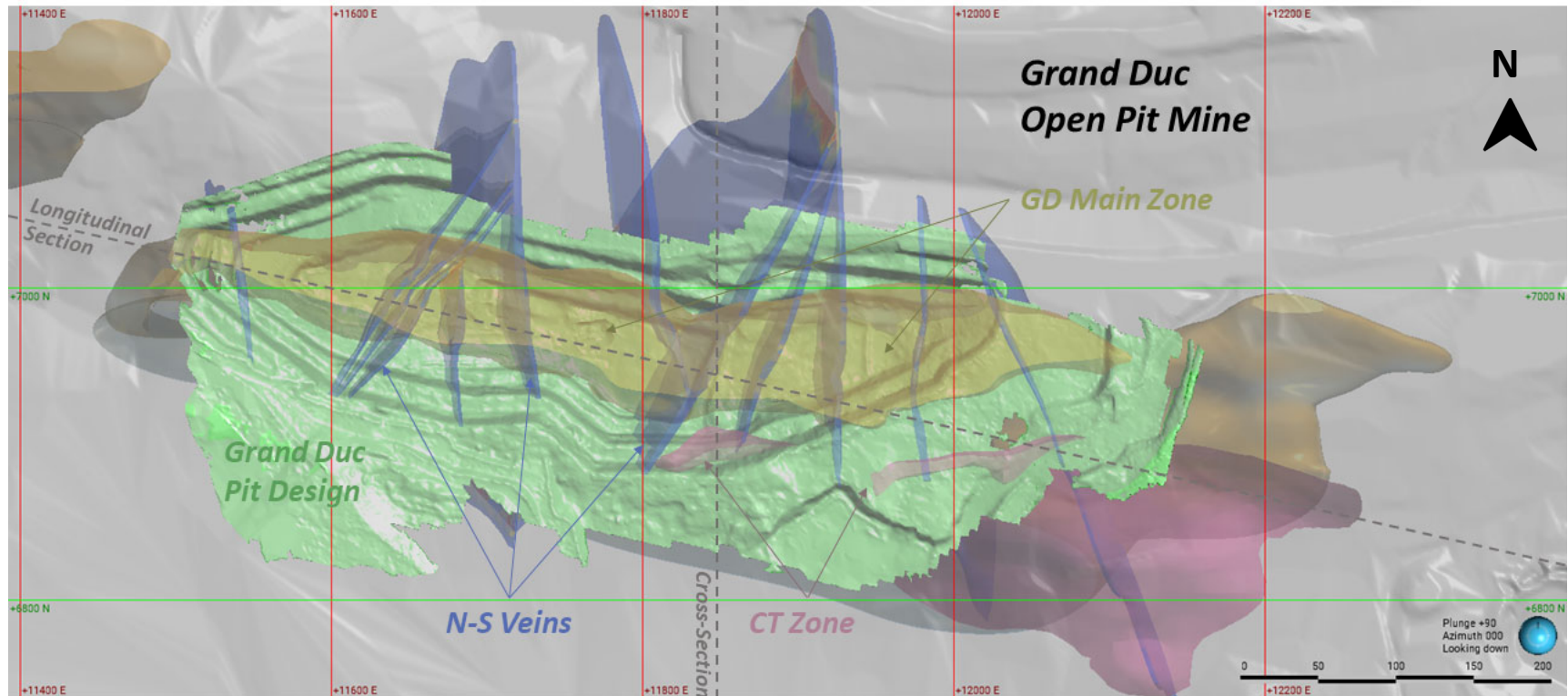

Note: Figure prepared by IAMGOLD, 2023.

Figure 7-16: Mineralized Zones Longitudinal Section, Grand Duc

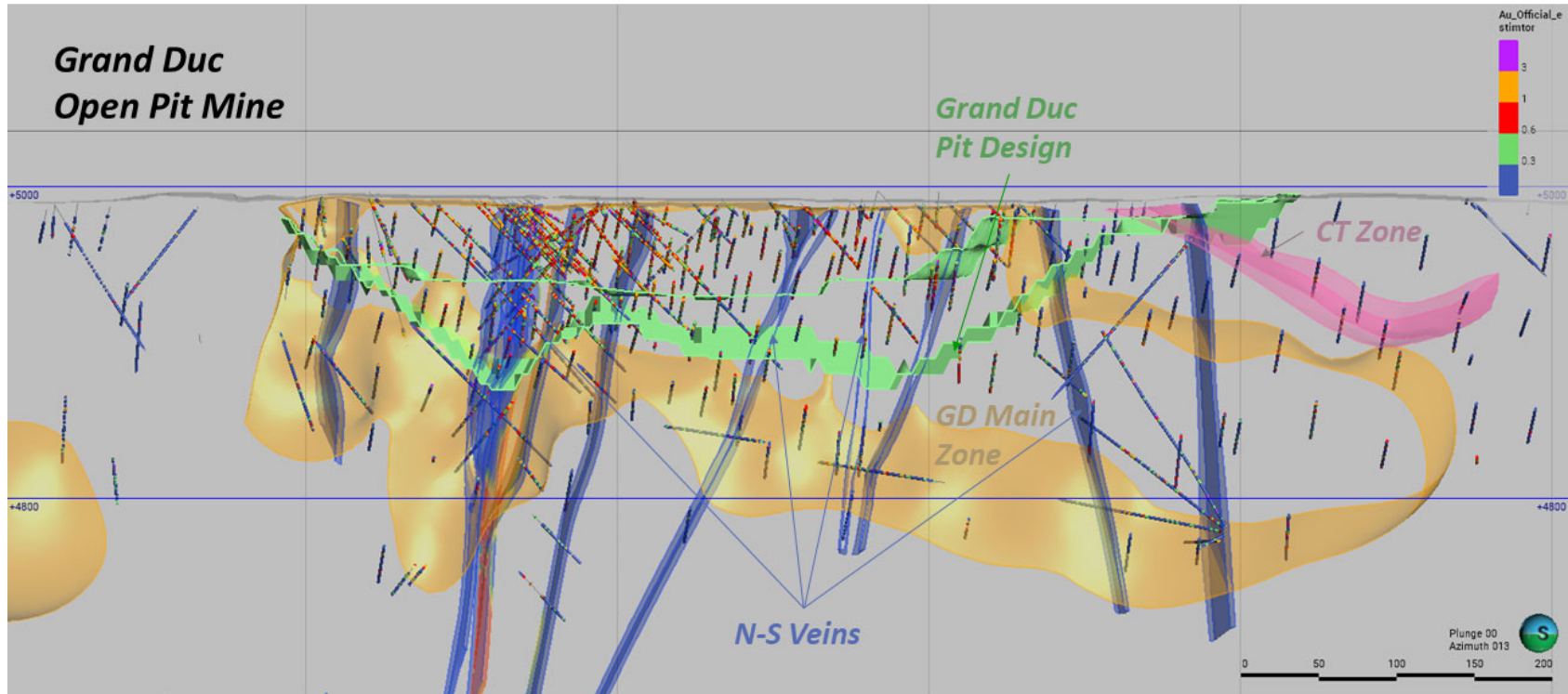

Note: Figure prepared by IAMGOLD, 2023. Figure looks northeast at an azimuth of 13°.

Figure 7-17: Cross-Section, Mineralized Zones, Grand Duc.

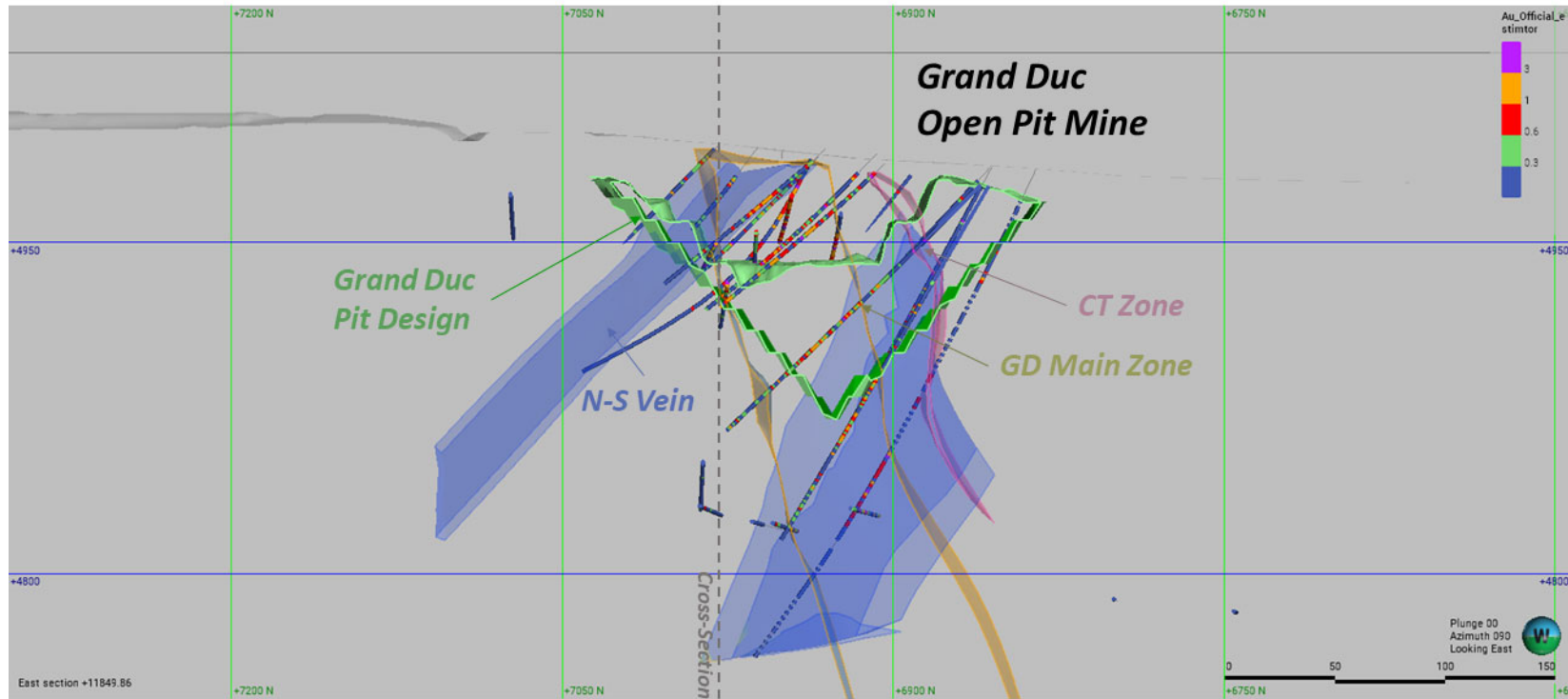

Note: Figure prepared by IAMGOLD, 2023. Figure looks east.

8 DEPOSIT TYPES

8.1 Introduction

The deposit types within the Project area are considered to be examples of greenstone-hosted orogenic gold deposits. Such deposits have many synonyms including mesothermal, mesozonal and hypozonal deposits, lode gold, shear zone-related quartz–carbonate deposits, or gold-only deposits (Groves et al., 1998).

The Westwood and Grand Duc deposits also include characteristics of gold-rich volcanic massive sulphide (VMS) deposits.

8.2 Deposit Type Description

8.2.1 Orogenic Gold Deposits

Orogenic gold deposits occur in variably deformed metamorphic terranes formed during Middle Archean to younger Precambrian, and continuously throughout the Phanerozoic. The host geological environments are typically volcano–plutonic or clastic sedimentary terranes, but gold deposits can be hosted by any rock type. There is a consistent spatial and temporal association with granitoids of a variety of compositions. Host rocks are metamorphosed to greenschist facies, but locally can achieve amphibolite or granulite facies conditions.

Gold deposition occurs adjacent to first-order, deep-crustal fault zones. Economic mineralization typically formed as vein fill of second- and third-order shears and faults, particularly at jogs or changes in strike along the crustal fault zones.

Mineralization styles vary from stockworks and breccias in shallow, brittle regimes, through laminated crack-seal veins and sigmoidal vein arrays in brittle-ductile crustal regions, to replacement- and disseminated-type orebodies in deeper, ductile environments.

Quartz is the primary constituent of veins, with lesser carbonate and sulfide minerals. Sulfide minerals can include pyrite, pyrrhotite, chalcopyrite, galena, sphalerite, and arsenopyrite. Gold is usually associated with sulfide minerals, but native gold can occur.

8.2.2 Gold-Rich VMS Deposits

Gold-rich VMS deposits can be found in located in greenstone belts and arc-related environments of all ages. The host geological environments are a variety of submarine volcanic terranes from mafic bimodal through felsic bimodal to bimodal siliciclastic in greenstone belts, typically metamorphosed to greenschist and lower amphibolite facies, and intruded by sub-volcanic intrusions and dyke-sill complexes.

Deposits consist of semi-massive to massive, lenticular, concordant sulphide lenses underlain by discordant stockwork feeder and replacement zones. Gold most commonly has an uneven distribution within the deposit due to both primary depositional controls and subsequent tectonic remobilization. The chemical signature of the ore is dominated by gold, silver, and copper or zinc, with locally high concentrations of arsenic, antimony, bismuth, selenium, tellurium, and mercury.

The mineralogy of gold-bearing and associated minerals is highly variable. Sulphide minerals are mainly pyrite and base-metal sulphides (chalcopyrite, sphalerite, galena) with a complex assemblage of minor phases including locally significant amounts of bornite, tennantite, sulphosalts, arsenopyrite, mawsonite and tellurides.

8.3 QP Comment on Item 8 “Deposit Types”

The QP considers that a greenstone-hosted orogenic gold or gold-rich VMS deposit model are a reasonable basis for exploration targeting for gold mineralization in the Project area.

9 EXPLORATION

9.1 Grids and Surveys

9.1.1 Westwood

The Westwood Mine is referenced using the local Doyon-Westwood mine grid. The reference survey work was completed by J.L. Corriveau & Associates in 1974. The Doyon-Westwood mine grid was built relative to the UTM17 NAD83 SCRS grid systems with a local Doyon YX (0,0) origin set to 5340523.3412, 670977.9517 and local Z set to 5002 m elevation relative to asl.

9.1.2 Grand Duc

The Grand Duc data are referenced using the local Doyon-Westwood mine grid. The open pit is surveyed topographically by the Westwood survey team using mine site survey drone equipment.

9.1.3 Fayolle

Data, including drill holes, channel sampling and grab samples used the UTM17 NAD83 coordinate system.

9.2 Geological Mapping

9.2.1 Westwood

Geological mapping was completed by Cambior and IAMGOLD geologists, and ranges from regional to outcrop level mapping.

Underground mapping at 1:250 scale is regularly undertaken during the week following development face headings and along the development backs.

9.2.2 Grand Duc

Geological strip mapping was completed in 2005, at a scale of 1:5,000.

Mapping in the open pit is undertaken at a 1:300 scale.

9.2.3 Fayolle

Geological mapping was completed by Hecla Quebec or Typhoon personnel in the period 2003–2019, typically at 1:10,000 scale.

9.3 Geochemical Sampling

9.3.1 Westwood

Early-stage exploration used rock chip sampling to vector into gold showings. This information has been superseded by drill data.

From 2004 to 2015, geochemical samples were taken on a regular basis along drill holes to characterize alteration and rock composition. For most of the exploration holes (large spacing) samples corresponding to a 10 cm to 20 cm piece of core were taken at approximately every 30 m, mainly in units #4.2 to #5.2. Samples were sent to ALS Chemex laboratory to be analyzed for whole rock and some trace elements. Over the years, a geochemical database of about 5,330 samples, has been built up and frequently used by geologists to distinguish facies. From 2015 to the Report effective date, core samples are analyzed in the Westwood core shack using an X-ray fluorescence (XRF) instrument to determine trace elements.

9.3.2 Grand Duc

Litho-geochemical, petrographic and X-ray diffraction studies were completed by the Geological Survey of Canada on selected samples taken from the Mooshla Intrusive Complex and some outcrops of the surrounding rocks (a total of 78 outcrops). This work was supported by core logging descriptions from 18 Cambior core holes and the underground mapping of drift 660 E at the Mouska Mine that crosscuts most of the Mooshla Intrusive Complex.

9.3.3 Fayolle

Five areas, covering a total surface area of 1,202.3 m² within the Fayolle property were stripped, and channel sampled by Hecla Quebec from 2010–2013 (Figure 9-1).

- Dike showing: 27 channel samples returned results ranging from 0.119–0.929 g/t Au over an area of 60.4 m²;

Figure 9-1: Strip Sampling, 2010–2013



Note: Figure from Poirier et al., (2013). Note that many of these showings are outside IAMGOLD's Fayolle property ground holdings, but are included for completeness.

- Vang and Vang Extension showings: 50 channel samples returned results ranging from 0.05–0.34 g/t Au over a total area of 405.1 m²;
- Barrick showing: 58 channel samples returned results ranging from 0.005–0.074 g/t Au over an area of 186.4 m²;
- FA-11-24 showing: 119 channel samples returned results ranging from 0.001–0.062 g/t Au over a total area of 669.4 m².

Soil and trench channel sampling was completed by Hecla Quebec in 2013–2014 over areas considered prospective for gold mineralization, focusing on areas of outcrop in historically delineated gold showings.

In general, the 300 trench channel samples collected did not identify elevated gold values other than at the Cinco prospect and in the Fayolle deposit area.

Two mobile metal ion soil surveys were conducted in 2013–2014 by Hecla Quebec and their third-party contractor Technominex Services Inc. on 100 m-spaced north–south grid lines with 25 m sample stations along the lines. A total of 1,035 samples were collected. Soil programs identified elevated gold values in sediments and albitized komatiites that contained pyrite and disseminated hematite. Anomalous gold values were returned in the region of the Cinco prospect and to the south of that prospect (Figure 9-2).

9.4 Geophysical Surveys

9.4.1 Westwood

Early-stage exploration programs completed by Cambior used a number of ground geophysical methods in support of prospect definition. These included ground magnetic, aeromagnetic, very low frequency (VLF), and induced polarization (IP). Pulse-electromagnetics (EM) was used in selected drill holes. This information has typically been superseded by drill data.

In 2008, an INFINITEM test survey was conducted in three short holes crossing and adjacent to the Warrenmac lens. The INFINITEM-method was previously employed by Abitibi Geophysics on selected deep holes to help locate major conductors within the favourable volcanic sequence. These holes started from 900 m below surface, extended to a depth of 2 km, and required huge loops to induce a sufficient electromagnetic field to detect conductors. Some weak in-hole and off-hole anomalies were detected and were explained by pyrite concentrations and veins within known mineralized corridors.

Figure 9-2: Mobile Metal Ion Survey

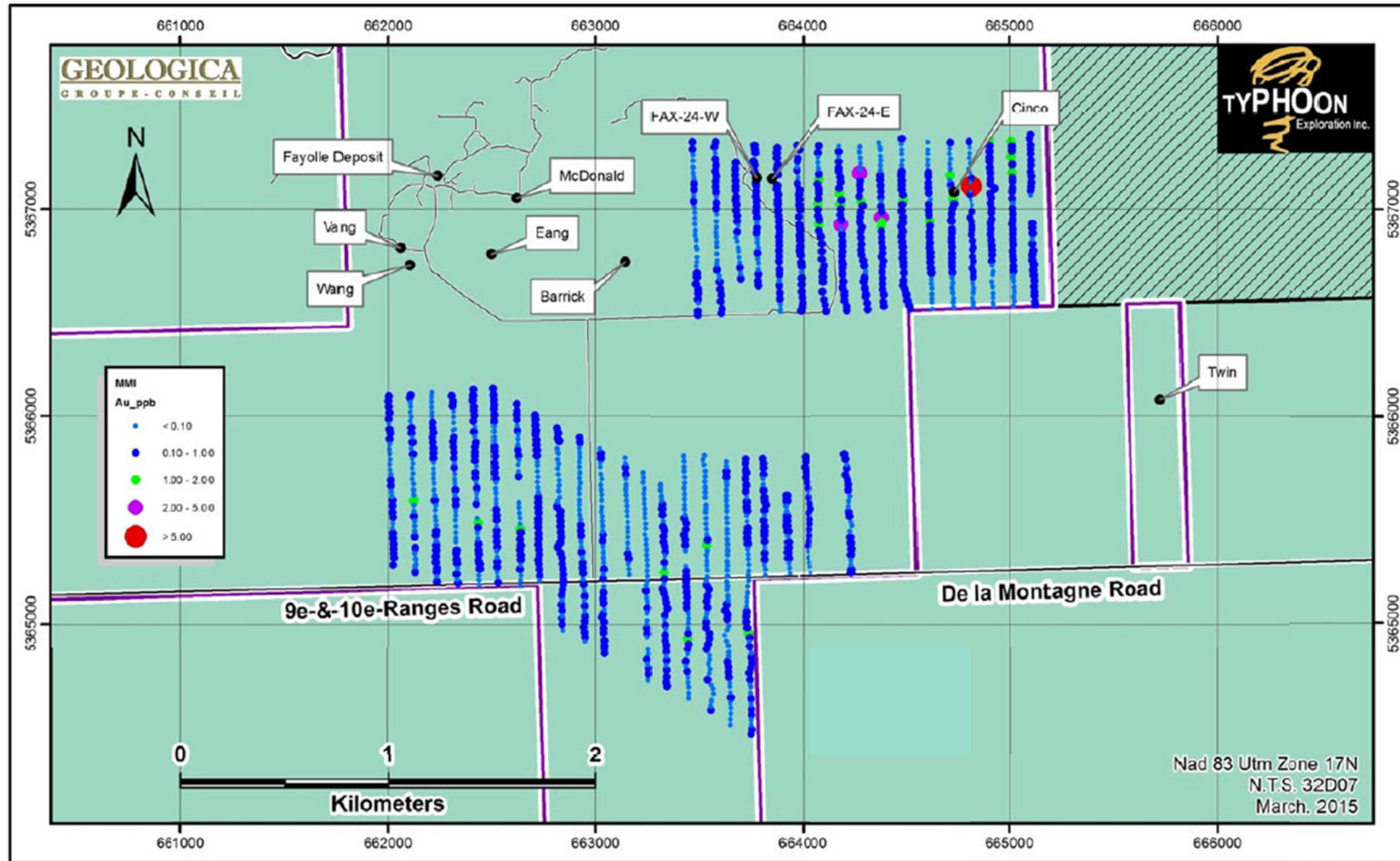

Note: Figure from Beaugard and Gaudrault (2015). Note that many of these surveys are outside IAMGOLD's Fayolle property ground holdings, but are included for completeness.

The 2008 survey was designed to reassess the method in the context of the Warrenmac lens area. The test was inconclusive due to the pyrite type encountered and the high sphalerite content. After the survey of the Warrenmac lens, it was concluded that the application of this method was inadequate for the investigation at depth because of the weak sulphide conductivity and the high operating costs.

IAMGOLD performed acoustic televiewer campaigns inside selected geotechnical core holes in 2018 and 2022 to obtain data on stresses from borehole breakout data collected from multiple wedges.

KORE Geosystems Inc. conducted three campaigns in 2018–2019:

- Two campaigns were to characterize stress between Level 132-09 and Level 156-00 and on Level 132-02 close to the Bousquet Fault following the seismic events of 2013, 2015, and 2017;
- The third campaign was to characterize stress on Level 132-10 following the seismic events of December 2018.

During 2002, an acoustic televiewer survey was conducted from Level 156-00 within one core hole to obtain information on the ground conditions eastward across the Bousquet fault.

9.4.2 Grand Duc

No geophysical programs have been conducted in the Grand Duc area.

9.4.3 Fayolle

Two magnetometer ground surveys were conducted in July and November 2013 by Abitibi Geophysics Inc. (Figure 9-3). The first survey covered 81.27 line km in the northern part of the Fayolle property. The second survey covered 144 line km over three grids in the southern part of the Fayolle property. The surveys showed six magnetic domains and an extensive network of brittle northeast- and southeast-trending faults.

A 2014 induced polarization survey was conducted jointly by Gérard Lambert (Geosciences) and TMC Geophysics, and identified 30 individual high IP anomalies distributed in the form of east–west oriented planar units (Figure 9-4). Anomalies were interpreted to be caused by sulfides, graphite, and alteration minerals.

Figure 9-3: Ground Magnetometer Geophysical Surveys, Fayolle Property

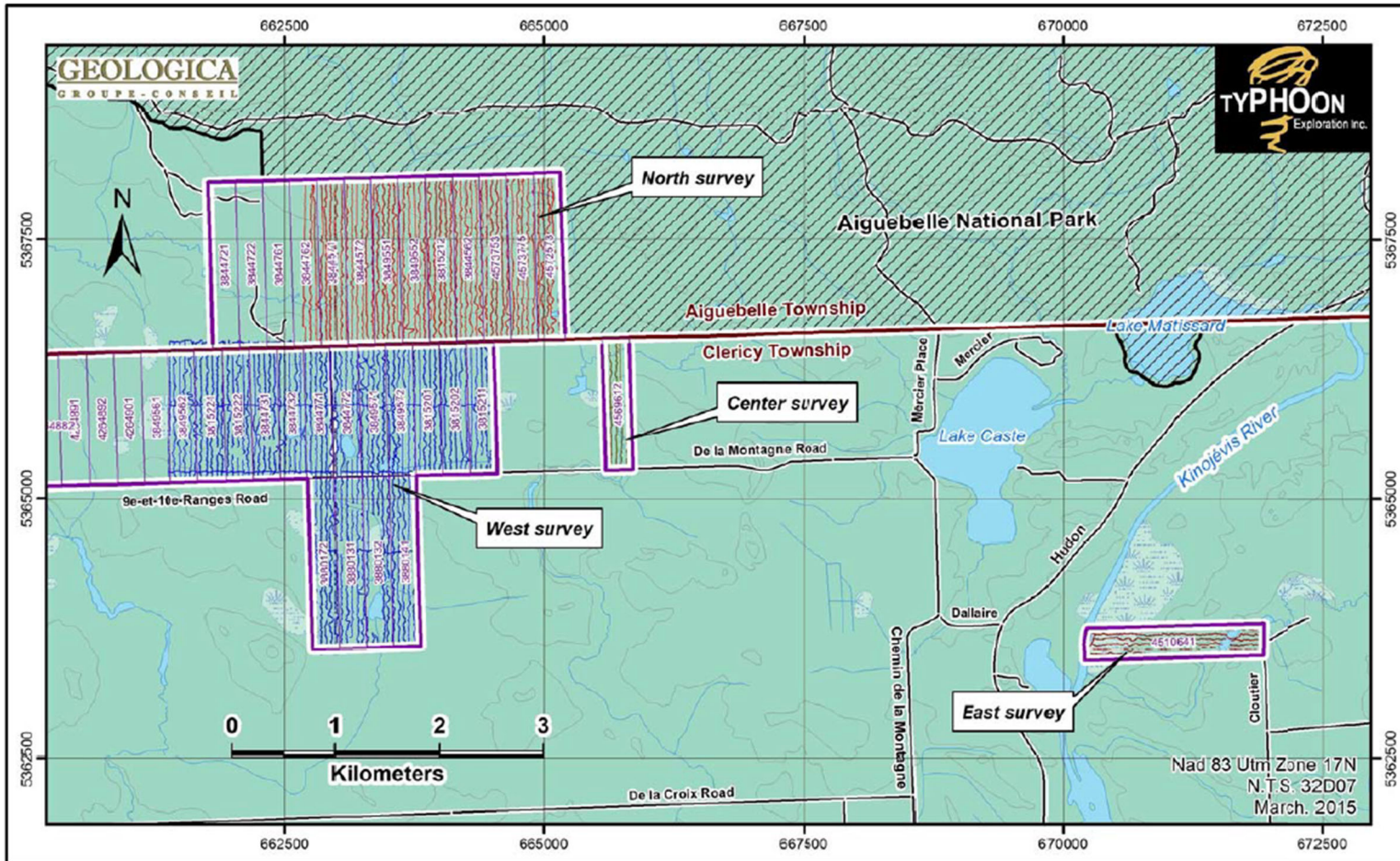

Note: Figure from Beauregard and Gaudreault (2015). Note that many of these surveys are outside IAMGOLD's Fayolle property ground holdings, but are included for completeness.

Figure 9-4: Ground IP Geophysical Surveys, Fayolle Property

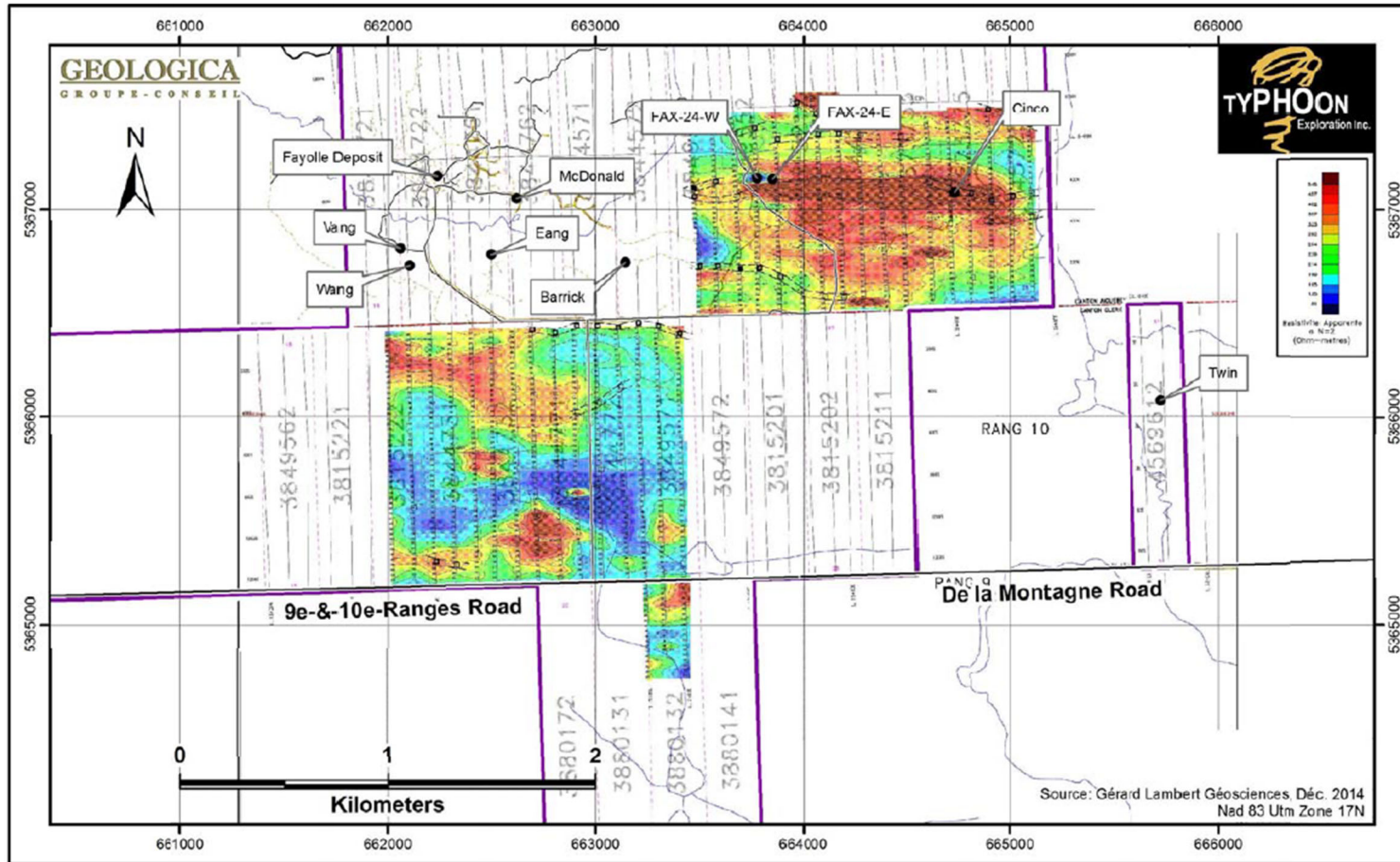

Note: Figure from Beaugard and Gaudreault (2015). Note that many of these surveys are outside IAMGOLD's Fayolle property ground holdings, but are included for completeness.

9.5 Exploration Potential

The Westwood deposit remains open at depth, westward and locally to the east along the untested mineralized Westwood, North and Zone-2 corridors.

The Grand Duc deposit remains open westward and locally to the east.

Exploration potential remains around the former Doyon mine. IAMGOLD plans to drill test along the western deposit extension from the near surface and at depth, and is planning a review of the exploration data available for the eastern deposit area.

Prospects in proximity to the mining operations include the untested sulphide mineralized portions of the Mooshla Intrusive Complex and mineralization that could be hosted within eastern extensions of the contact tonalite (CT) zone along the south flank of the Grand Duc open pit toward the mined-out Doyon West open pit.

Regional prospects include the Mooshla B (#2), WDMC (#6) sectors based on partial historic drill results and poorly-tested geophysical IP anomalies to the north along target areas #4 and #5, which trend northwest to east–west (Figure 9-5).

There are geological similarities between the Westwood deposit area and the adjacent LaRonde mining complex, operated by Agnico Eagle Mines Limited (Agnico Eagle). Exploration will review the potential for mineralization between the Westwood deposit and the former Ellison mine, which is part of the LaRonde mining complex (area shown in red circle on Figure 9-6). IAMGOLD is exploring the potential for exploration synergy with Agnico Eagle, such as siting drill pads in Agnico Eagle's property, drilling back into the IAMGOLD ground holdings.

Figure 9-5: Prospective Areas, Doyon-Westwood Property

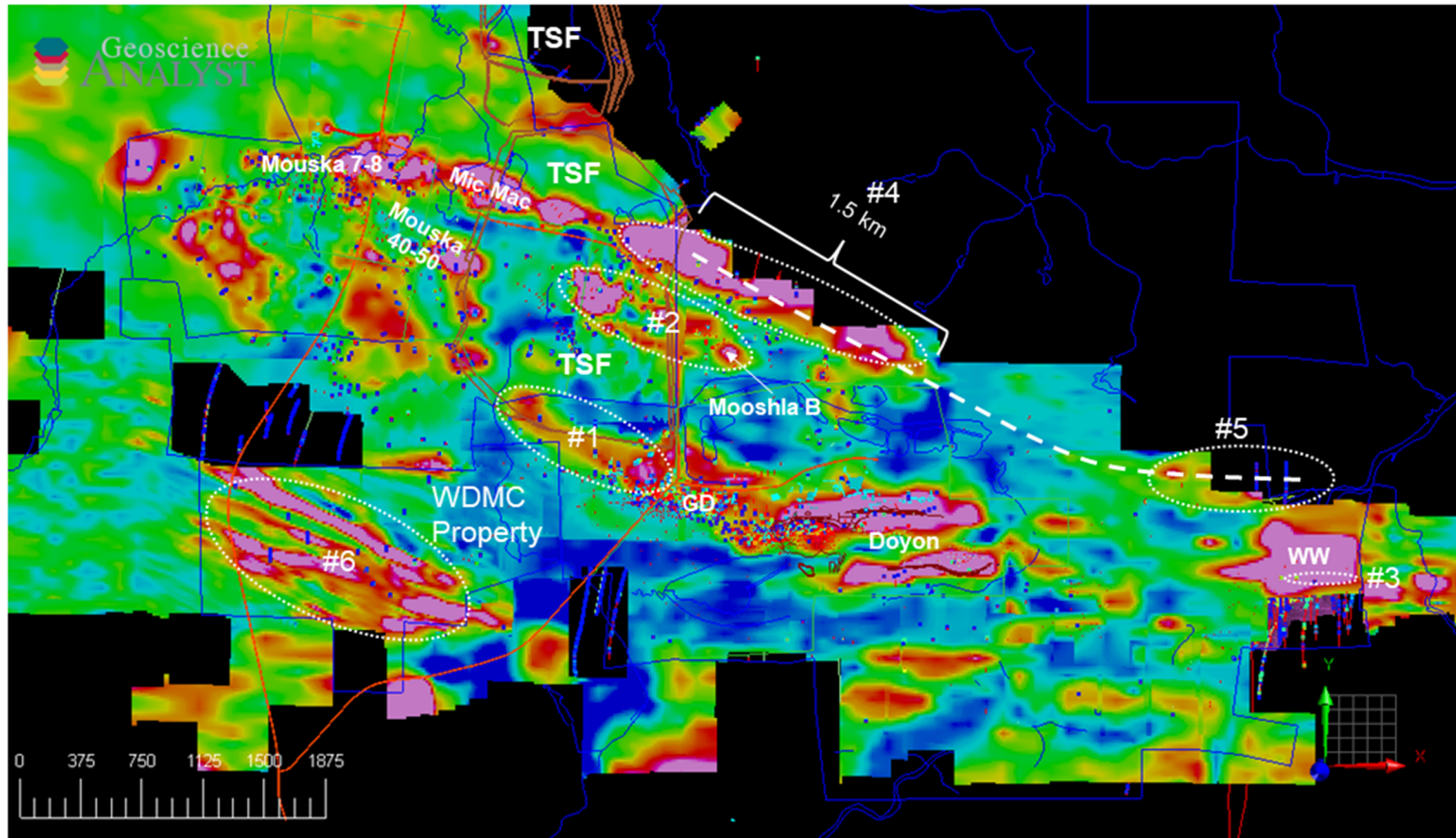

Note: Figure prepared by IAMGOLD, 2023. Figure north is to top of image.

Figure 9-6: Prospective Area, Westwood–Ellison

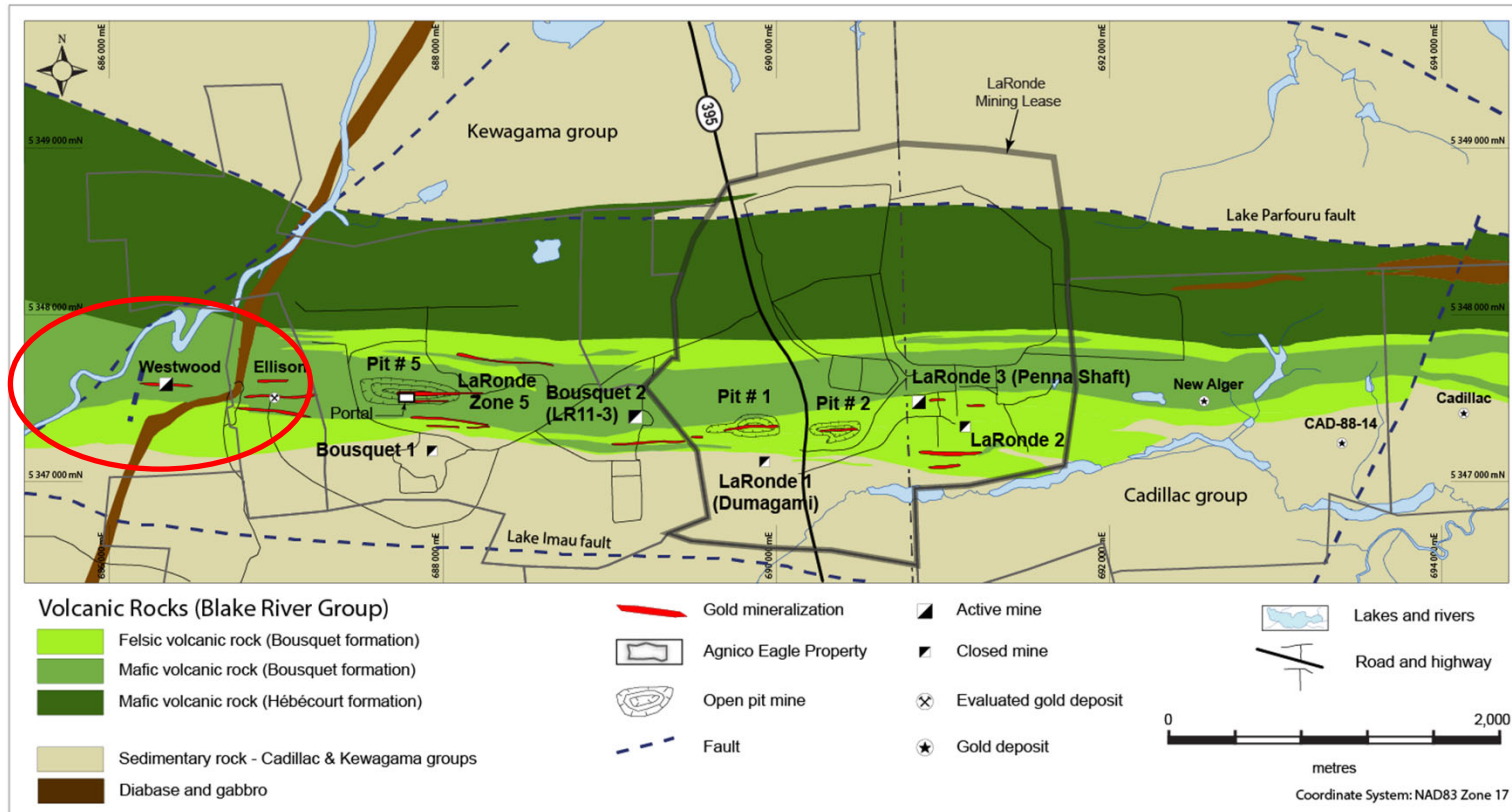

Note: Figure prepared by Agnico Eagle, 2024.

10 DRILLING

10.1 Introduction

As at 1 October, 2024, the total combined surface and underground core drilling in the Doyon, Grand Duc, Mouska, Westwood and Fayolle mining areas and surrounding tenures totals 29,400 drill holes for 3,959,041 m of drilling from surface and underground. Much of this total includes drill holes from former operations, where the mineralization is mined-out.

All drilling within the Fayolle property was completed prior to IAMGOLD's property interest. IAMGOLD completed no drilling on the property other than geotechnical support holes.

Drill holes were completed for exploration, infill, Mineral Resource and Mineral Reserve estimation, geotechnical, hydrological, condemnation and metallurgical purposes.

A drill summary table for the entire Project area, comprising the Doyon-Westwood and Fayolle Property areas is provided as Table 10-1. Individual property drill totals are included as Table 10-2 (Westwood), Table 10-3 (Grand Duc–Doyon), Table 10-4 (Mouska), and Table 10-5 (Fayolle).

Figure 10-1 shows the drilling by operator for the Doyon–Westwood Property, and Figure 10-2 shows the drilling by the major mining areas in the Doyon–Westwood Property. Figure 10-3 shows the drilling in the Fayolle Property area.

The close-out date of the Westwood database is 14 November, 2023. The Mineral Resource estimate is based on 6,270 core drill holes (1,328,575.38 m) drilled from surface and underground between 1938–2024. Drill collar locations used in estimation are shown in Figure 10-4. Drilling since the database close-out date is discussed in Section 10.8.

The close-out date of the Grand Duc database is 15 November, 2023. Mineral Resource estimation is based on 650 core holes (104,799 m drilled). There has been no additional drilling since the database close-out date.

Table 10-1: Project Drill Summary Table

Mine/Area	Operator	Number of Drill Holes		Metres Drilled (m)		Total Holes	Total Metres Drilled (m)
		Surface	Underground	Surface	Underground		
Mouska	Pre-IAMGOLD	583	4,430	166,711	478,141	5,013	644,851
	IAMGOLD	1	862	366	188,061	863	188,427
	<i>Sub-total</i>	<i>584</i>	<i>5,292</i>	<i>167,076</i>	<i>666,202</i>	<i>5,876</i>	<i>833,278</i>
Doyon	Pre-IAMGOLD	1,631	14,054	259,373	1,287,671	15,685	1,547,043
	IAMGOLD	62	204	8,533	34,760	266	43,293
	<i>Sub-total</i>	<i>1,693</i>	<i>14,258</i>	<i>267,906</i>	<i>1,322,431</i>	<i>15,951</i>	<i>1,590,337</i>
Grand Duc	IAMGOLD	333	—	41,540	—	333	41,540
	<i>Sub-total</i>	<i>333</i>	<i>—</i>	<i>41,540</i>	<i>—</i>	<i>333</i>	<i>41,540</i>
Westwood	Pre-IAMGOLD	208	38	105,059	33,176	246	138,235
	IAMGOLD	107	6,462	60,022	1,177,930	6,569	1,237,952
	<i>Sub-total</i>	<i>315</i>	<i>6,500</i>	<i>165,080</i>	<i>1,211,107</i>	<i>6,815</i>	<i>1,376,187</i>
Fayolle	Pre-IAMGOLD	425	—	117,700	—	425	117,700
	<i>Sub-total</i>	<i>425</i>	<i>—</i>	<i>117,700</i>	<i>—</i>	<i>425</i>	<i>117,700</i>
Totals		3,350	26,050	759,302	3,199,739	29,400	3,959,041

Table 10-2: Drill Summary Table, Westwood

Year	Operators/ Companies	Surface Drilling		Underground Drilling		Total Number of Drill Holes	Total Drilled Metres (m)
		Number of Drill Holes	Drilled Metres (m)	Number of Drill Holes	Drilled Metres (m)		
1938	pre-IAMGOLD	1	121	—	—	1	121
1944		2	338	—	—	2	338
1945		8	377	—	—	8	377
1946		28	2,214	—	—	28	2,214
1970		2	270	—	—	2	270
1973		2	228	—	—	2	228

Year	Operators/ Companies	Surface Drilling		Underground Drilling		Total Number of Drill Holes	Total Drilled Metres (m)
		Number of Drill Holes	Drilled Metres (m)	Number of Drill Holes	Drilled Metres (m)		
1977		15	3,325	—	—	15	3,325
1978		5	675	—	—	5	675
1982		6	1,291	—	—	6	1,291
1983		5	1,292	—	—	5	1,292
1987		23	11,921	—	—	23	11,921
1988		23	7,233	—	—	23	7,233
1989		8	4,385	—	—	8	4,385
1990		13	10,577	—	—	13	10,577
1991		5	6,304	—	—	5	6,304
1994		2	1,961	—	—	2	1,961
1995		6	6,279	—	—	6	6,279
1996		13	3,513	—	—	13	3,513
1999		3	1,217	—	—	3	1,217
2001		10	6,781	—	—	10	6,781
2002		8	7,540	—	—	8	7,540
2003		6	11,674	—	—	6	11,674
2004		4	9,017	1	933	5	9,949
2005		10	6,527	6	7,729	16	14,256
2006		—	—	31	24,515	31	24,515
<i>Sub-total pre-IAMGOLD</i>		<i>208</i>	<i>105,059</i>	<i>38</i>	<i>33,176</i>	<i>246</i>	<i>138,235</i>
2007	IAMGOLD	6	2,485	37	35,721	43	38,206
2008		59	27,472	128	56,292	187	83,763
2009		37	21,080	236	86,654	273	107,734
2010		2	5,480	272	85,469	274	90,949
2011		3	3,505	257	80,821	260	84,325
2012		—	—	426	91,225	426	91,225
2013		—	—	627	87,935	627	87,935
2014		—	—	620	73,922	620	73,922
2015		—	—	640	75,254	640	75,254
2016		—	—	571	81,554	571	81,554

Year	Operators/ Companies	Surface Drilling		Underground Drilling		Total Number of Drill Holes	Total Drilled Metres (m)
		Number of Drill Holes	Drilled Metres (m)	Number of Drill Holes	Drilled Metres (m)		
2017		—	—	597	112,332	597	112,332
2018		—	—	647	109,076	647	109,076
2019		—	—	440	65,528	440	65,528
2020		—	—	351	48,520	351	48,520
2021		—	—	152	20,129	152	20,129
2022		—	—	170	24,457	170	24,457
2023		—	—	171	27,195	171	27,195
2024*		—	—	120	15,848	120	15,848
<i>Sub-total IAMGOLD</i>		<i>107</i>	<i>60,022</i>	<i>6,462</i>	<i>1,177,930</i>	<i>6,569</i>	<i>1,237,952</i>
Total WESTWOOD		315	165,080	6,500	1,211,107	6,815	1,376,187

Table 10-3: Drill Summary Table, Grand Duc–Doyon

Year	Operators/ Companies	Surface Drilling		Underground Drilling		Total Number of Drill Holes	Total Drilled Metres (m)
		Number of Drill Holes	Drilled Metres (m)	Number of Drill Holes	Drilled Metres (m)		
Unknown	pre-IAMGOLD	270	37,794	1	30	271	37,824
1935		5	343	—	—	5	343
1936		4	935	—	—	4	935
1937		9	1,967	1	50	10	2,017
1939		11	1,248	—	—	11	1,248
1940		4	824	—	—	4	824
1941		3	1,410	—	—	3	1,410
1963		2	245	—	—	2	245
1970		1	137	—	—	1	137
1974		1	92	—	—	1	92
1975		7	1,431	—	—	7	1,431
1978		5	438	—	—	5	438
1980		22	4,135	—	—	22	4,135
1981		146	29,460	—	—	146	29,460

Year	Operators/ Companies	Surface Drilling		Underground Drilling		Total Number of Drill Holes	Total Drilled Metres (m)
		Number of Drill Holes	Drilled Metres (m)	Number of Drill Holes	Drilled Metres (m)		
1982		168	17,695	1	152	169	17,848
1983		106	13,143	25	2,768	131	15,910
1984		73	10,185	132	20,313	205	30,498
1985		86	9,777	244	29,593	330	39,369
1986		218	21,771	402	34,800	620	56,571
1987		113	13,670	688	62,203	801	75,873
1988		90	14,727	812	75,347	902	90,073
1989		50	12,056	857	74,614	907	86,671
1990		58	1,735	539	46,980	597	48,714
1991		—	—	644	55,032	644	55,032
1992		9	133	708	61,730	717	61,863
1993		6	2,552	558	59,084	564	61,637
1994		7	3,573	567	64,563	574	68,137
1995		20	16,134	776	66,134	796	82,267
1996		19	16,102	843	54,798	862	70,901
1997		—	—	794	64,606	794	64,606
1998		—	—	531	54,278	531	54,278
1999		14	2,901	581	60,485	595	63,386
2000		28	1,257	622	55,977	650	57,234
2001		7	8,139	726	66,382	733	74,521
2002		4	2,236	757	74,488	761	76,724
2003		3	29	686	71,935	689	71,964
2004		1	1,161	520	55,119	521	56,280
2005		61	9,937	566	39,415	627	49,353
2006		—	—	473	36,794	473	36,794
<i>Sub-total pre-IAMGOLD</i>		<i>1,631</i>	<i>259,373</i>	<i>14,054</i>	<i>1,287,671</i>	<i>15,685</i>	<i>1,547,043</i>
2007	IAMGOLD	6	1,158	187	22,762	193	23,920
2008		18	2,627	5	4,910	23	7,537
2009		7	1,067	11	7,033	18	8,100
2010		—	—	1	55	1	55

Year	Operators/ Companies	Surface Drilling		Underground Drilling		Total Number of Drill Holes	Total Drilled Metres (m)
		Number of Drill Holes	Drilled Metres (m)	Number of Drill Holes	Drilled Metres (m)		
2020		31	3,681	—	—	31	3,681
<i>Sub-total IAMGOLD</i>		<i>62</i>	<i>8,533</i>	<i>204</i>	<i>34,760</i>	<i>266</i>	<i>43,293</i>
Total Doyon		1,693	267,906	14,258	1,322,431	15,951	1,590,337
2015	IAMGOLD	31	1,938	—	—	31	1,938
2016		27	4,838	—	—	27	4,838
2020		121	8,338	—	—	121	8,338
2021		69	11,617	—	—	69	11,617
2022		85	14,809	—	—	85	14,809
<i>Sub-total IAMGOLD</i>		<i>333</i>	<i>41,540</i>	<i>—</i>	<i>—</i>	<i>333</i>	<i>41,540</i>
Total Grand Duc		333	41,540	—	—	333	41,540
Total Doyon / Grand Duc		2,026	309,446	14,258	1,322,431	16,284	1,631,877

Table 10-4: Drill Summary Table, Mouska

Year	Operators/ Companies	Surface Drilling		Underground Drilling		Total Number of Drill Holes	Total Drilled Metres (m)
		Number of Drill Holes	Drilled Metres (m)	Number of Drill Holes	Drilled Metres (m)		
Unknown	pre-IAMGOLD	—	—	22	356	22	356
1960		—	—	2	124	2	124
1963		—	—	1	30	1	30
1975		3	558	—	—	3	558
1978		9	1,136	—	—	9	1 136
1981		—	—	1	37	1	37
1982		5	843	—	—	5	843
1985		7	839	—	—	7	839
1987		183	63,346	—	—	183	63 346
1988		41	11,381	1	45	42	11 427
1989		19	4,519	260	20,761	279	25 280
1990		—	—	442	34,161	442	34 161
1991		—	—	133	6,668	133	6 668

Year	Operators/ Companies	Surface Drilling		Underground Drilling		Total Number of Drill Holes	Total Drilled Metres (m)
		Number of Drill Holes	Drilled Metres (m)	Number of Drill Holes	Drilled Metres (m)		
1992		—	—	188	7,969	188	7 969
1993		6	2,291	192	9,131	198	11 422
1994		11	6,423	320	29,177	331	35 600
1995		18	8,569	223	12,421	241	20 991
1996		25	16,384	260	16,802	285	33 185
1997		14	8,660	253	22,353	267	31 013
1998		13	3,912	153	17,612	166	21 524
1999		11	2,611	203	27,770	214	30 381
2000		1	285	217	20,852	218	21 137
2001		1	152	223	31,270	224	31 422
2002		2	2,929	287	49,427	289	52 356
2003		—	—	245	40,786	245	40 786
2004		—	—	45	9,111	45	9 111
2005		2	1,995	306	47,007	308	49 002
2006		212	29,877	453	74,271	665	104 148
<i>Sub-total pre-IAMGOLD</i>		583	166,711	4,430	478,141	5,013	644,851
2007	IAMGOLD	—	—	169	59,028	169	59 028
2008		—	—	104	35,877	104	35 877
2009		1	366	94	14,677	95	15 043
2010		—	—	138	15,113	138	15 113
2011		—	—	167	32,944	167	32 944
2012		—	—	189	30,151	189	30 151
2013		—	—	1	270	1	270
<i>Sub-total IAMGOLD</i>		1	366	862	188,061	863	188,427
Total Mouska		584	167,076	5,292	666,202	5,876	833,278

Table 10-5: Drill Summary Table, Fayolle

Year	Operators/ Companies	Surface Drilling	
		Number of Drill Holes	Drilled Metres (m)
Unknown	pre-IAMGOLD	6	569
1947		1	213
1958		11	195
1985		3	235
1986		4	509
1987		28	5,551
1994		4	535
1995		3	582
1997		13	4,446
2004		14	3,274
2005		29	8,719
2006		31	5,462
2007		28	8,113
2008		36	12,815
2009		4	1,170
2010		31	10,392
2011		120	42,385
2012		27	6,584
2014		11	4,202
2019		21	1,749
<i>Sub-total pre-IAMGOLD</i>		425	117,700
Total Fayolle		425	117,700

Figure 10-1: Drill Collar Location Plan By Operator, Doyon–Westwood Property

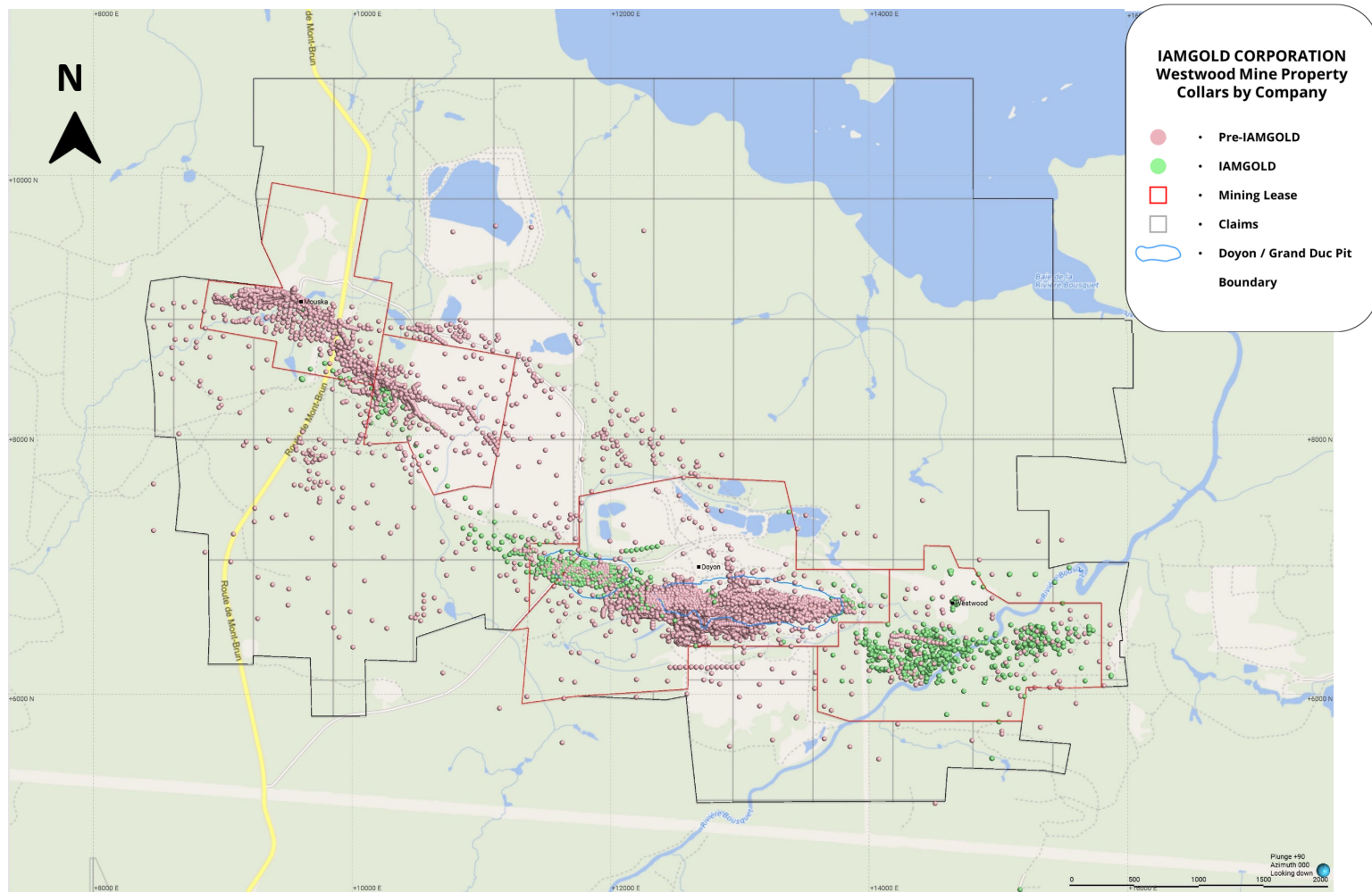

Note: Figure prepared by IAMGOLD, 2024.

Figure 10-2: Drill Collar Location Plan By Location, Doyon–Westwood Property

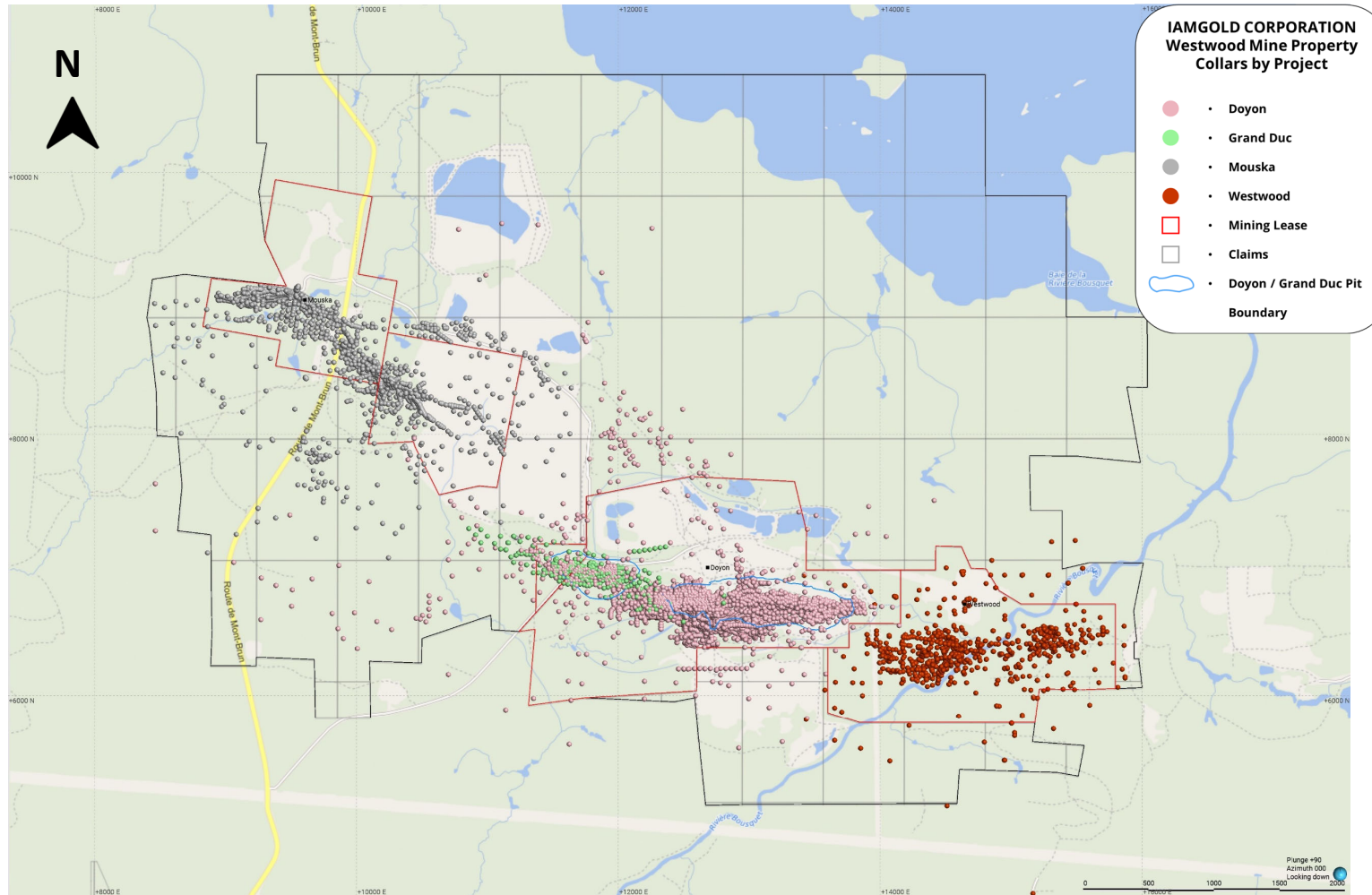

Note: Figure prepared by IAMGOLD, 2024.

Figure 10-3: Drill Collar Location Plan, Fayolle Property

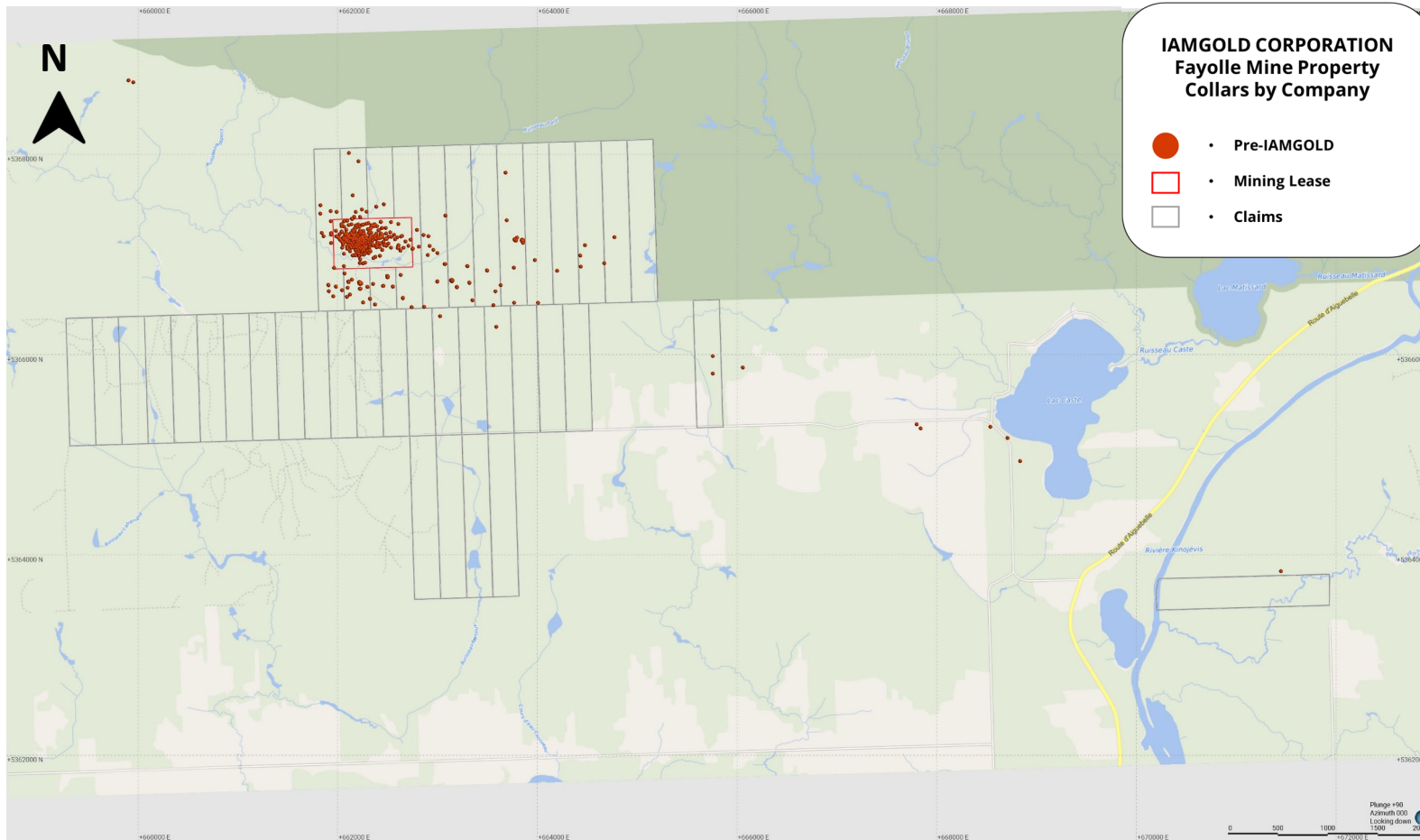

Note: Figure prepared by IAMGOLD, 2024.

Figure 10-4: Drill Collar and Trace Location for Drilling Supporting Mineral Resource Estimates, Westwood

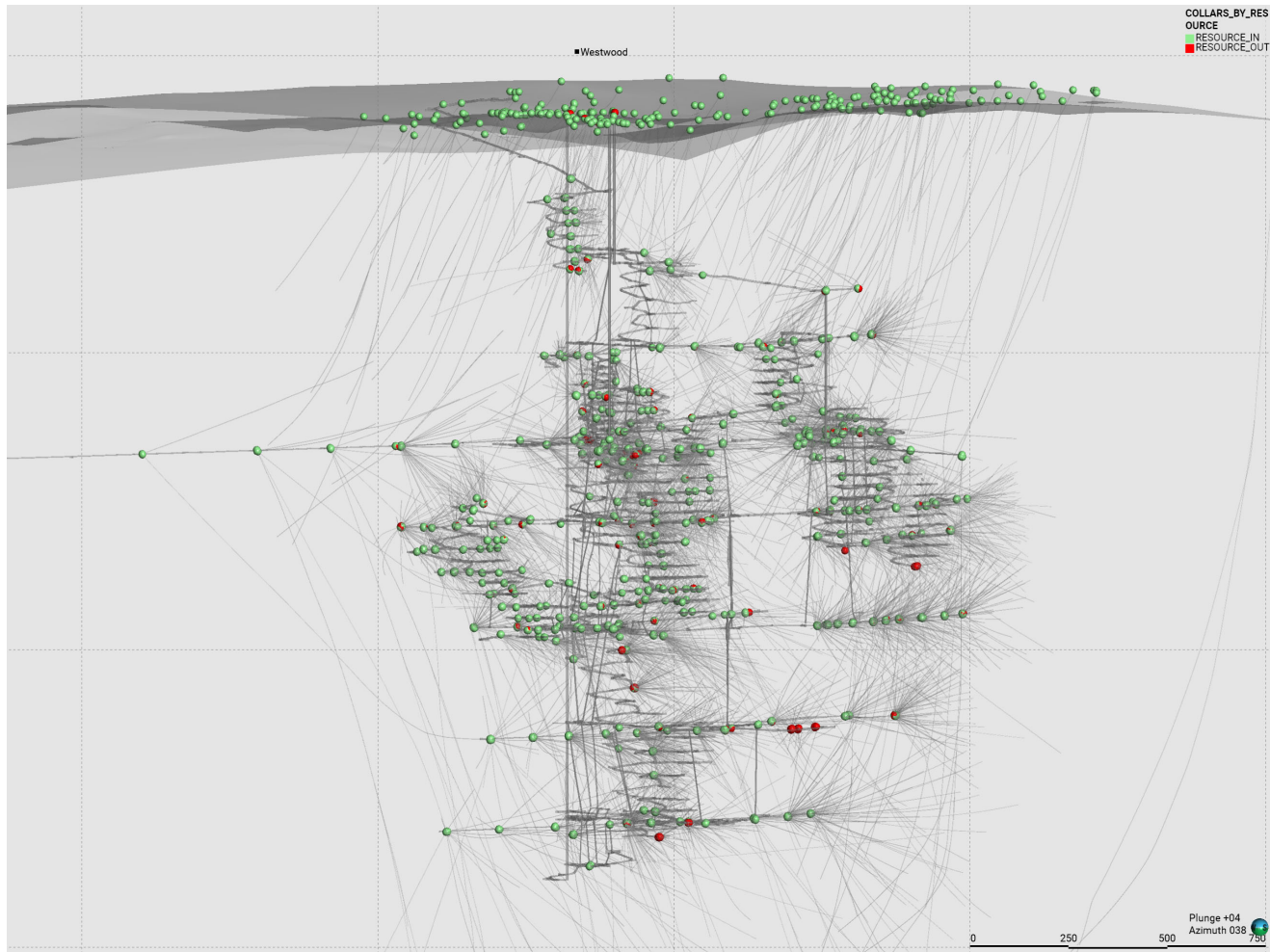

Note: Figure prepared by IAMGOLD, 2024.

10.2 Drill Methods

10.2.1 Doyon-Westwood Property

Where known, core drill contractors on the Westwood and Grand Duc deposits include Orbit Garant Drilling, Boreal Drilling, Boart Longyear, and Machine Roger.

Core sizes include NQ (47.6 mm core diameter), BQ (36.4 mm), and ATW (30.1 mm). The NQ-size is used at the beginning of a drill hole or for the entire drill hole to help control deviation. NQ-size is also used to increase the recovery if strongly sheared or fractured rock is expected. BQ is typically used for valuation and for some definition drilling work, while the ATW size is used only for shallow definition drilling (<50 m).

Grade control drilling at Grand Duc is completed by Galarneau, a third-party contractor, using blasthole and Sandvik Leopard drill rigs.

10.2.2 Fayolle Property

The only known drill contractor was Hébert Drilling Inc. based in Amos, Québec.

Core drilling was completed using NQ.

10.3 Geological Logging

10.3.1 Doyon-Westwood Property

10.3.1.1 Pre-IAMGOLD

Core was washed and photographed prior to logging and sampling.

Core was initially logged for geotechnical parameters, including core recovery; breakability, hardness, alteration, schistosity intensity; rock quality designation (RQD): and rock mass rating.

Subsequently, core was geologically logged, with information recorded including lithology, alteration, sulphur content, texture, core recovery, structure, and veining.

Sample intervals were marked up by the logging geologists.

10.3.1.2 IAMGOLD

10.3.1.2.1 Geological Logging

Core is placed by the drillers into wooden core boxes, prior to being transported to the core shack. Core boxes are transported by piling the boxes on a flat car which is pulled by a train to the shaft station and then sent to the surface by the shaft cage and then to the core shack. At the core shack, the core is washed to remove the drilling fluids and residues.

Core logging is performed by geologists. Logging includes lithology, alteration, sulphur content, texture, core recovery, structure, and veining. Geologists are also responsible for the sample selection. Sample intervals are marked on the core by geologists and the sample tags are placed at the end of each sample interval.

Drill holes are systemically photographed after logging and sample tags are inserted.

After logging is completed, the core shack technicians (samplers) saw the exploration core for sampling and send half of the core for assaying. The whole core for definition and valuation samples are sent to the laboratory.

RC grade control drill holes are not logged.

10.3.1.2.2 Geotechnical Logging

Geotechnical data, including core recovery, rock quality designation (RQD) and breakability, hardness, alteration, and schistosity intensities are recorded. A visual scale is used to describe the degree of alteration and foliation of the core.

In areas of intense sericite and chlorite alteration underground, point load tests are performed perpendicular and along the foliation every metre to test the cohesion of the foliation and the strength of the matrix of the rock. This is supplemented by uniaxial and triaxial compressive strength tests.

In underground areas where the lithologies form a sequence of harder and softer rock layers, care is taken to identify hard and brittle using a combination of logging and X-ray fluorescence spectroscopy. Point load test results are also used as an aid in identifying and quantifying the strength of juxtaposed contrasting units.

A conventional geotechnical logging approach based on the Q' system (Barton and al, 1974) is used for more homogeneous rock masses in the underground operations.

10.3.2 Fayolle Property

10.3.2.1 Pre-IAMGOLD

The core logging and sampling procedure requires the drill core to be boxed, covered and sealed at the drill rigs, and transported by the drilling crews to the core logging facility in Saint-Norbert-de-Mont-Brun. From 2006 to 2009, core logging and sampling was performed by Geologica Inc consultants under the supervision of Typhoon geologists. For 2010 to 2012, core logging and sampling was done by Geologica, Explolab, Lutsvisky and Typhoon personnel over Geologica or Typhoon and Aurizon supervision.

10.4 Recovery

10.4.1 Doyon-Westwood Property

Overall, the core recovery is usually very good (>95%) but for the main fault zone and the sericitic schist intervals recovery may locally decrease to 50%. Even when the recovery is good, the RQD is generally poor within the main fault zone area.

Recoveries are not recorded for the RC grade control drill holes.

10.4.2 Fayolle Property

No recovery information is available for the Fayolle drill campaigns.

10.5 Collar Surveys

10.5.1 Doyon-Westwood Property

10.5.1.1 Pre-IAMGOLD

Information is not available for all programs. Where known, the collars were surveyed using a total station TCR-1105 (Leica) instrument.

10.5.1.2 IAMGOLD

Surface collar coordinates are obtained in 3D using total station Leica TCRP1205, Leica MS60 or Leica TS15 instruments. Surveyors export the survey file in CSV format and subsequently send the information to the relevant geologists. Data are subsequently checked and imported into the Acquire database.

Underground hole collars from drill holes completed from 2013 to 1 October 2024, were surveyed by mine surveyors. Collar coordinates are obtained in 3D from total station Leica MS60, Leica TS15 or Leica TS16 instruments.

10.5.2 Fayolle Property

Information is not available for all programs. Where known, collar locations were determined using surveyors from Corriveau J.L. & Associés. No information is available as to the survey equipment used.

10.6 Down Hole Surveys

10.6.1 Doyon-Westwood Property

10.6.1.1 Pre-IAMGOLD

Information is not available for all programs. Where known, down hole surveys were performed at nominal 50 m downhole intervals with Reflex or Flexit tools depending on the availability of the instrument. In some cases, readings were taken with a Pajari tool, or while other surveying instruments were away for maintenance.

10.6.1.2 IAMGOLD

The deviation is often difficult to control depending on the relation (direction/dip) between holes and the regional foliation. At sharp angles, holes tend to lift while at more open angles, the tendency is to deepen. In the case of deep holes, wedges are often used to reach upper targets because it is easier to control the deviation. IAMGOLD considers that this is a reasonable way to duplicate intersections obtained from the parent hole.

Control drilling was tested in 2010 in one drill hole to reach a precise target at ± 50 m. Tech Directional Services was the contractor chosen to perform the test. The “Devico” technique used, permitted a

stronger deviation in a desired direction using sophisticated technology. The result was partially positive since good deviation was obtained but the test was stopped due to ground difficulties.

All drill holes are surveyed in the first 21 m using the single shot function of the Reflex tool, to ensure that the planned orientation and dip of the hole is respected. The hole is stopped and a new hole is collared a few centimetres away if the deviation from the planned azimuth and/or dip is too great.

Down hole surveys were performed at nominal 50 m downhole intervals, and since 2022 at 25 m intervals, with Reflex or Flexit tools depending on the availability of the instrument. In some cases, readings were taken with a Pajari tool, mainly at the beginning of the program or while other surveying instruments were away for maintenance.

Some drill holes have been surveyed with the Geophysic – INFINITEM method (refer to discussion in Section 9.4.1).

RC grade control drill holes are not down-hole surveyed.

10.6.2 Fayolle Property

From 2010–2012, drill holes were oriented using a CorientR instrument. Down-hole surveys were collected using a FLEXIT instrument.

During the Typhoon campaigns, downhole dip and azimuth were surveyed using a DerviShot tool from DeviCore. A first survey was taken after completing the casing (3–12 m) and another at the bottom of the hole. For holes >30 m deep, a survey was taken at mid-distance from the first survey and the end of hole.

10.7 Sample Length/True Thickness

At Westwood, most drill holes are planned and drilled with azimuths perpendicular to the deposit lithology, with dips typically ranging from +45° to -65°. Drilled intercepts are typically wider than true intercepts. The orientation of the drilling to the mineralization is shown in the plans and sections provided as Figure 10-5 and Figure 10-6.

In the Grand Duc area, drilled intercepts are typically wider than true intercepts. The orientation of the drilling to the mineralization was shown in the cross-sections included as Figure 7-15, Figure 7-16, and Figure 7-17.

Figure 10-5: Typical Plan View Showing Drill Holes and Mineralized Zones used for the Current Mineral Resources Estimates, Westwood (elevation 3640; level 1320-00)

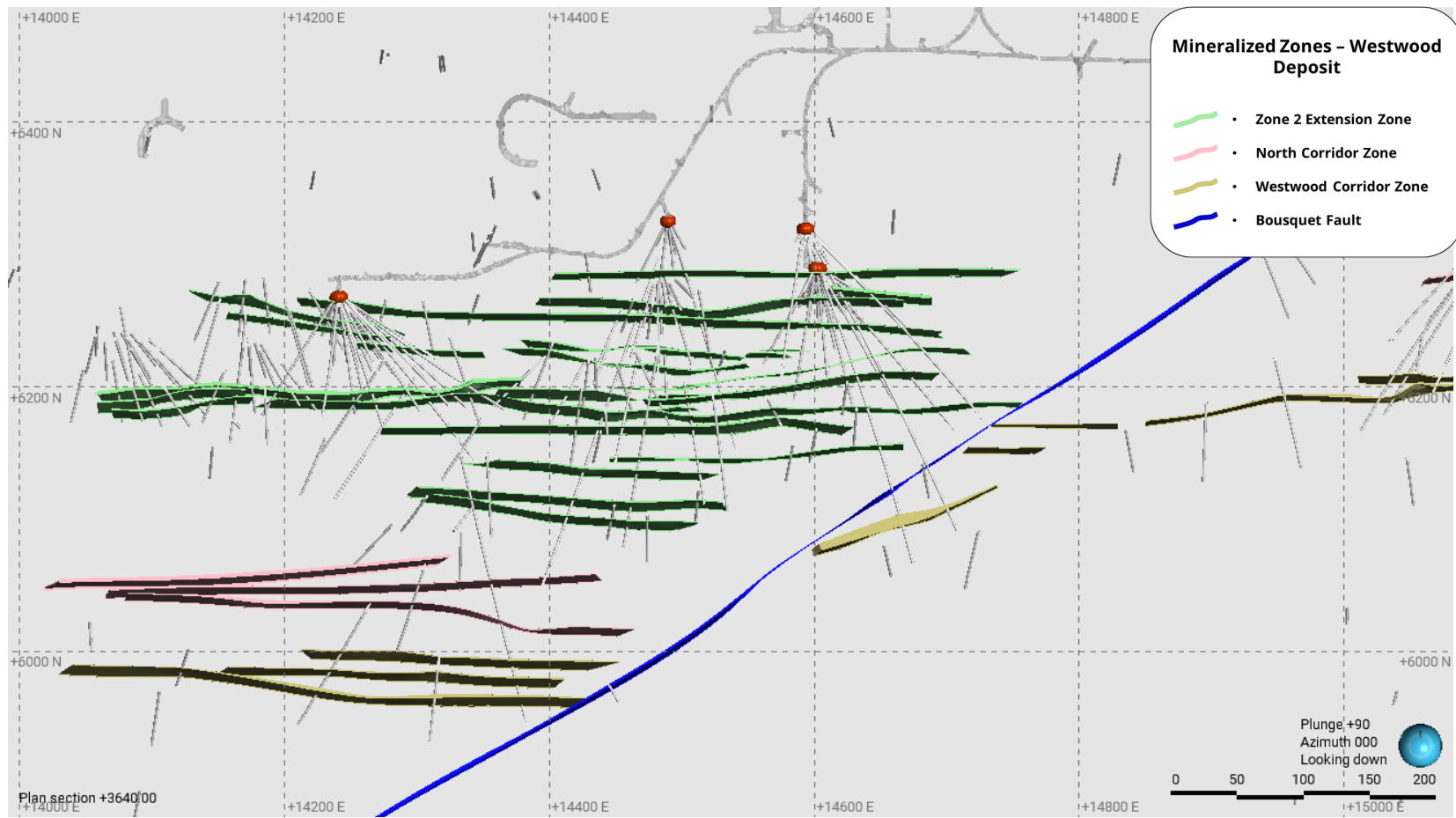

Note: Figure prepared by IAMGOLD, 2024.

Figure 10-6: Typical Cross Section Showing Drill Holes and Mineralized Zones used for the Current Mineral Resource Estimate, Westwood (easting 14,300)

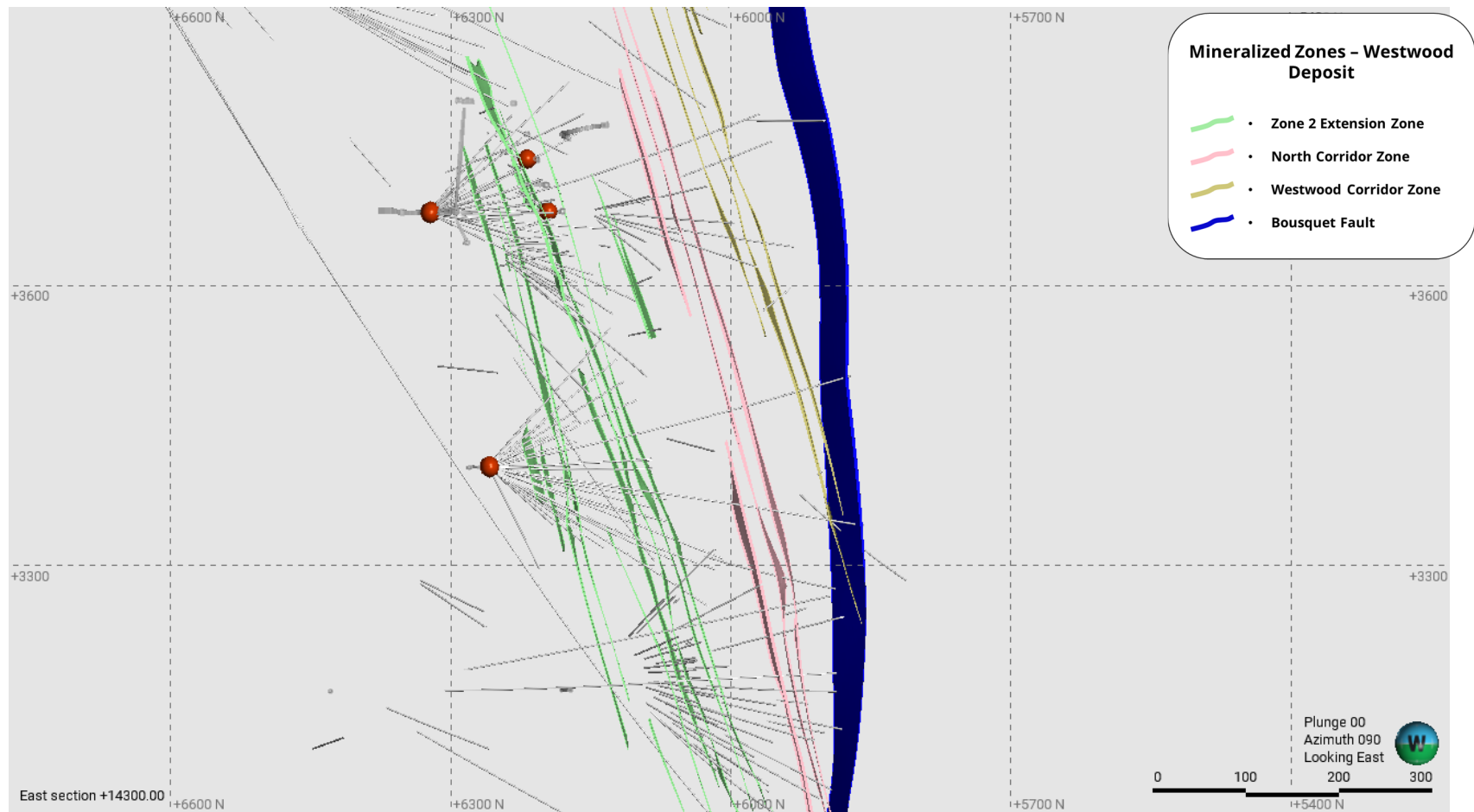

Note: Figure prepared by IAMGOLD, 2024.

10.8 Drilling Since Westwood Database Close-Out Date

After the close-out date of the 2024 estimation database and during the preparation of the 2024 Mineral Resource estimate, and the technical report, IAMGOLD continued with its underground drilling program.

The QP is of the opinion that these results are not material to the Mineral Resource estimate for the Westwood deposit in this Report.

Following a review of the new drilling results to 31 December, 2024 in relation to the current model, the QP noted that

- The results support the general model of geological continuity and the distribution of gold grades;
- Some of the Mineral Resources currently in the Inferred category will potentially be able to be upgraded to the Indicated category with additional study;
- Continuity of known mineralization is being demonstrated laterally and at depth.

IAMGOLD had completed more than 45,591 m of new underground core drilling, and had received 25,070 assay results between the database closeout date and 31 December, 2024. These 2024 drill holes are not included in the Mineral Resource estimate. The QP does not believe that the omission of these holes will materially affect the Mineral Resource estimate, and the decision to leave them out is supported by the current geological models (see discussion in Section 14).

Once all the current drilling program results are known and considered final, and QA/QC data have been reviewed, the QP recommends a Mineral Resource update be completed for Westwood.

10.9 QP Comment on Item 10 “Drilling”

For all resource definition and infill drill programs, drilling and surveying were conducted in accordance with industry-standard practices. The drilling as performed provides suitable coverage of the zones of gold mineralization.

Collar and down hole survey methods used provide support for reliable sample locations.

Drilling methods provide acceptable core recovery.

Logging procedures provide consistency in descriptions.

These data are considered to be suitable for Mineral Resource and Mineral Reserve estimation at Westwood and Grand Duc.

There are no drilling, drill sampling or drill recovery factors in the resource definition and infill drill program data that support the estimates that are known to the QPs that could materially impact the accuracy and reliability of the results other than the known recovery issue in certain lithologies.

In the main fault zones, such as the Bousquet Fault, and the sericite schist alteration area, core recovery may locally decrease to 50%. The upper part of Z239-A vein is located inside the sericite schist alteration area and at least 21 veins have part of their tonnage inside the Bousquet Fault corridor. Poor core recovery in these zones could have an impact on the precision and reliability of the drilling results in these areas, and, consequently, on the Mineral Resource estimate for these zones.

11 SAMPLE PREPARATION, ANALYSES AND SECURITY

11.1 Sampling Methods

11.1.1 Geochemical Sampling

Geochemical sampling is not used to support Mineral Resource estimation.

11.1.2 Core Sampling

11.1.2.1 Doyon-Westwood Property

11.1.2.1.1 Pre-IAMGOLD

Information is not available for all programs. Where known, samples from a mineralized zone were about 1 m in length, although some zones could be sampled on 0.5 m lengths to locate possible high grades along the vein being sampled. Outside of visually-mineralized areas, sample lengths typically ranged from 1–1.5 m.

11.1.2.1.2 IAMGOLD

All core logging and sampling takes place in the core shack. Prior to logging, drill core measurements (wooden blocks) are verified. If major offsets are observed, they are corrected with the representative of the drilling company. Then after core measurement, marks are drawn onto the core.

During logging, the geologist selects and indicates sample intervals by marking the beginning and end of each sample interval on the core. The geologist places two tags for the same sample ID at the end of each sample interval for assaying and inputs the analyses required for that sample into the database. A third sample tag remains in the booklet for reference.

Core is typically whole-core sampled; however, at the geologist's discretion, the core can be marked up for half-core sampling.

Core is photographed prior to sampling.

Splitting and sampling is completed by experienced technicians. A table-feed circular core saw is used to cut the core in two equal parts when requested. One half remains in the core box with its sample tag.

The second half is put in a plastic bag with its related tag. Otherwise, the whole core is taken as the sample and is placed in a plastic bag with its tag.

All plastic bags are identified with the sample number manually written on the bag as the sample tag. The sample bag is put in a box, listed in the database, and then delivered to the laboratory along with a submittal sheet that indicates the type of analysis to be performed on each sample.

Exploration drill holes were sampled as follows:

- Samples within the upper tuffaceous mafic/intermediate volcanic rocks hosting Zone 2 were halved, with one half sent to the laboratory and the second half retained as a reference sample;
- Samples within the Hebecourt Formation, in tholeiitic quartz (feldspar) phyric felsic rocks and the lower part of the tuffaceous mafic/intermediate volcanic rocks hosting Zone 2 consisted of whole core.

In mineralized zones, the initial definition drill holes were sampled depending on the requirements at the time:

- Core halved, with one half of the core sent to the Doyon plant for acid generation and flotation tests, and the second half sent for laboratory analysis;
- Core halved, with one half sent to the laboratory and the second half retained as a reference sample;
- Whole core sent for analysis.

Samples varied in length, but were typically 1 m long in mineralization and 1–1.5 m long outside known mineralized zones.

Currently, the core sample lengths vary, depending on sample location:

- For samples bordering mineralization, but not likely to be mineralized, the sample interval is 1.5 m;
- For samples in, or likely to host mineralization, the sample interval is 1 m;
- For samples within the major domains, Z2, CN, and WW, the sample interval is 0.5 m to discriminate between veins in close proximity, such that each vein has its own sample. Each vein should be in the center of its own 50 cm long sample.

The general intent is to sample either side of a mineralized zone to obtain a grade over an actual thickness of at least 3 m encompassing the vein.

The same sampling methods are used for Grand Duc core samples.

11.1.2.2 Fayolle Property

11.1.2.2.1 Pre-IAMGOLD

Core sample intervals were selected based on the presence of visible mineralization, alteration, or structural features. Minimum and maximum sample lengths were generally established at 0.3 and 1.5 m, respectively. The core of the selected interval was first cut in half using a standard table-feed circular rock saw, with one half put aside for shipment to the laboratory. Half of all sampled core was retained for future reference. A sample tag bearing the same number was placed at the end of the sampled interval.

Samples were placed into sample bags and grouped according to core drill hole.

11.1.3 Grade Control Sampling

RC grade control drill holes at Grand Duc are typically sampled as four 2.5 m sample intervals, with the samples taken from cuttings collected in sample pans (Figure 11-1). Selective production sample drilling is done at 2.5 m intervals. Blast hole sampling is conducted at 5 m intervals.

11.1.4 Underground Channel Sampling

Drilling results are validated during ore development at Westwood by face chip and muck samples. The samples are taken in every one to two faces with a sample interval from 1–1.5 m wide.

11.2 Density Determinations

Density measurements taken for the Westwood and Grand Duc deposits were performed by the immersion method.

The average value for Westwood Zone 2 Extension is 3.01 t/m³ (713 samples) and 2.97 t/m³ for the North Corridor (82 samples).

Figure 11-1: RC Grade Control Sampling

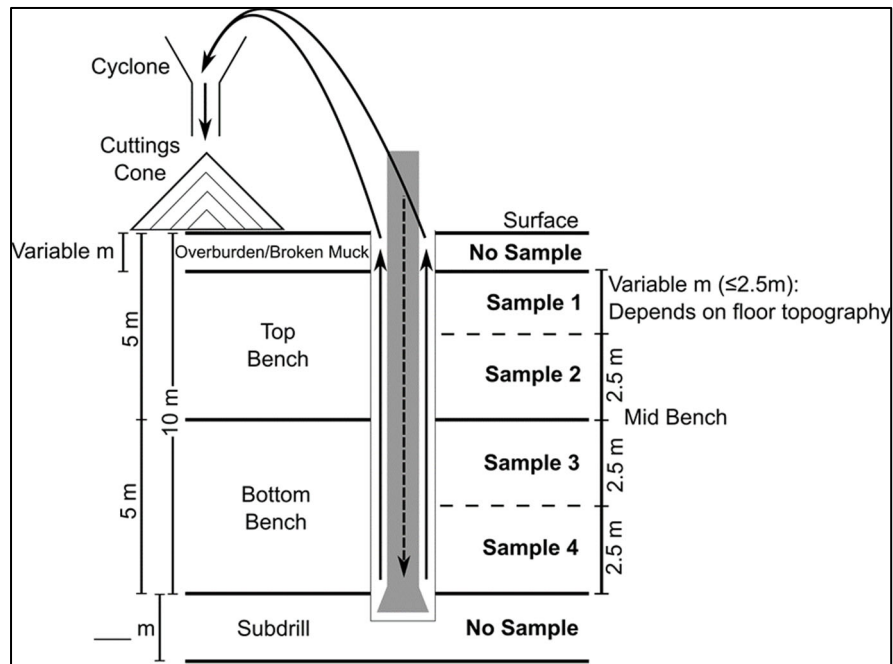

Note: Figure prepared by IAMGOLD, 2023.

A total of 2,152 density measurements were taken from the Westwood Corridor: 1,240 samples from the vein-type mineralization and 912 samples from the sulphide rich zones. The averages of those tests are 3.04 t/m³ for the vein-type and 3.54 t/m³ for the sulphide lenses.

Density determinations at Grand Duc are based on measurements from 10 core holes, taken in 2021, and completed by third-party laboratory, ALS Minerals Laboratories (ALS Chemex), using the water displacement method. The laboratory data are supported by water-displacement method density determinations performed by IAMGOLD personnel on muck samples. Densities range from 2.68–2.7 t/m³.

11.3 Analytical and Test Laboratories

11.3.1 Doyon-Westwood Property

Samples were initially sent to the Doyon mine laboratory, which was not independent. The laboratory held ISO14001 accreditations. The on-site laboratory was closed in November 2013.

From late 2013 to 2016, samples were sent to Accurassay Laboratories, located in Rouyn-Noranda, Québec. The laboratory was independent of IAMGOLD and is not accredited.

From 2017 onward, samples have been sent to ALS Chemex, located in Val-d'Or, Québec. The laboratory is independent of IAMGOLD. ALS Chemex has ISO 9001:2008 certification and ISO/IEC 17025:2005 accreditation for selected analytical techniques.

When the Doyon mine laboratory capacity was exceeded, or re-assays were required, samples could be sent to Laboratoire Expert Inc. (Laboratoire Expert) in Rouyn-Noranda, Québec. Subsequent to the Doyon mine laboratory closure, Laboratoire Expert was retained as the primary check laboratory. Laboratoire Expert is independent of IAMGOLD and is not accredited.

ALS Chemex was used as a check laboratory on the Doyon mine laboratory base metal results in 2006–2008.

All production samples were prepared at Actlabs in Val d'Or and sent to Laboratoire Expert for analysis. This Actlabs facility is independent of IAMGOLD and is not accredited.

As a consequence of service availability of and abnormally long delays in receiving production analytical results, from May 2022 onward, MSALABS in Val d'Or, Québec was used for analysis of production samples. MSALABS is independent of IAMGOLD and was not accredited during the initial use period. MSALABS obtained ISO/IEC 17025 accreditations for selected analytical techniques in August, 2023.

Actlabs in Sainte-Germaine-Boulé, Quebec was used as the check laboratory from 2020–2024. This Actlabs facility is accredited to ISO/IEC 17025:2017, and is independent of IAMGOLD.

Selected production samples could be prepared at the Actlabs Val d'Or facility and analyzed at the Sainte-Germaine-Boulé facility.

11.3.2 Fayolle Property

Samples in the period 2006–2009 were prepared and analysed at Laboratoire Expert.

Samples in the period 2006–2009 and 2010–2012 were prepared and analysed at ALS-Chemex in Val d'Or, Québec. The laboratory was independent of Hecla Quebec and is independent of IAMGOLD. The laboratory held ISO 17025 accreditations.

Techni-Lab S.G.B. Abitibi Inc. (later acquired by Actlabs) located in Sainte-Germaine-Boulé, was used as a check laboratory for the 2010–2012 ALS Chemex assays. The laboratory was independent of Hecla

Quebec, and is independent of IAMGOLD, and held ISO17025 accreditations for selected analytical techniques at the time the laboratory was used.

11.4 Sample Preparation

11.4.1 Doyon-Westwood Property

Sample preparation methods varied over time with the changes in laboratory provider. Methods are summarized in Table 11-1.

11.4.2 Fayolle Property

11.4.2.1 Pre-IAMGOLD

The core samples at Laboratoire Expert were crushed to 90% passing 2 mm (10 mesh). A 300-g fraction was pulverized using a ring mill to 85% passing 75 µm (200 mesh).

The core samples at ALS Chemex were crushed to 70% passing 2 mm (10 mesh). A 250 g fraction was pulverized using a ring mill to 85% passing 75 µm (200 mesh).

11.5 Analysis

11.5.1 Doyon-Westwood Property

Analytical methods varied over time with the changes in laboratory provider. Methods are summarized in Table 11-2.

11.5.2 Fayolle Property

11.5.2.1 Pre-IAMGOLD

Gold was analyzed by fire assay with an AAS finish using a 30 g and/or 50 g nominal sample weight. From 2006–2009, samples with grades >1.0 g/t Au were re-assayed with a gravimetric finish. After 2009, samples with gold grades >10.0 g/t Au were re-assayed with a gravimetric finish.

Table 11-1: Sample Preparation Methods, Doyon-Westwood

Laboratory	Method
Doyon Mine Laboratory	Atomic absorption (AA): crushed to 75% passing 10 mesh; fire assay (FA): crushed to ¼ inch, then further crushed to 90% passing 10 mesh. 300–400 g subsample pulverized to 85% passing 200 mesh. Production samples preparation consists of drying, crushing to 70% passing 2 mm, and pulverizing to 85% passing 74 µm.
Laboratoire Expert	Crushed in a jaw crusher to ¼ inch then crushed with a second roll crusher to 90% passing through 10 mesh. 300 g sub-sample pulverized using a ring pulverizer to 90% passing 200 mesh.
Accurassay	Crushed in a jaw crusher to ¼ inch then crushed with a second jaw crusher to 85% passing through 10 mesh. 500 or 1 000 g subsample pulverized using an automated Herzog pulveriser to 85% passing 200 mesh
ALS Chemex	Crushed to 70% passing through 10 mesh (2 mm). 250 g sub-sample pulverized to 85% passing 200 mesh (75 µm)
Actlabs Val D'Or and Sainte-Germaine-Boulé	Crushed to 80% passing 10 mesh, 200–300 g sub-sample pulverized to 95% passing 200 mesh
MSALABS	Crushed to 10 mesh (2 mm)

Table 11-2: Analytical Methods, Doyon-Westwood

Laboratory	Method
Doyon Mine Laboratory	Fire assay was used for well gold mineralized zones; all other samples were analysed using atomic absorption (AA). 30 g sample used for fire assay. If free gold was noted, two different sub-samples were taken from two 30 g pulps, and each sub-sample was analyzed twice. For AA, a 5 g sample was used. If results were >1,500 ppb Au, then the sample reject was sent back to preparation to meet a 90% passing 10 mesh criterion, and a fire analysis was performed on a 30 g sub-sample. If the sample assayed >17 g/t Au, a gravimetric assay was performed.
Laboratoire Expert	30 g sub-sample assayed using fire assay with an AA finish. If assays were >1,000 ppb, the sample was reassayed using a gravimetric method. Samples initially analysed using gravimetry that were >10 g/t Au were reassayed using gravimetry.
Accurassay	30 g sub-sample for atomic absorption finish (FA-AA) and on a 50 g sub-sample for gravimetric finish (FA-Gravi). If the FA-AA result was >10 g Au/t, then a gravimetric determination was performed on a new 50 g sub-sample obtained from the original pulp. If there was free gold, the fire assay–gravimetric method was automatically performed on two different sub-samples obtained from two distinct pulps of 50 g each. Each sub-sample was analysed twice, which gave four fire assay–gravimetric method assay results for the same sample.
ALS Chemex	30 g sub-sample assayed using AA finish (method Au-AA23). If the gold grade was >10 g/t Au, the sample was reassayed using a gravimetric method (Au-GRA21). If there was free gold, the Au-GRA21 method was automatically performed on two different sub-samples obtained from

Laboratory	Method
	<p>each of two 30 g pulps. Each sub-sample was analyzed twice, which gave four fire assay–gravimetric method assay results for the same sample.</p> <p>On request, a multi-element analysis using inductively coupled plasma atomic emission spectroscopy could be performed (method ME-ICP 41), which consisted of a 37-element suite, including Ag, Cu, Zn, Pb, and Fe.</p>
Actlabs	<p>Gold via aqua regia digest followed by AA finish (method 8-AR ICP) or inductively coupled plasma optical emission spectroscopy (ICP-OES). Where samples return grades of >5 g/t Au, reanalyzed using fire assay/gravimetric finish.</p>
MSALABS	<p>A robot positions samples in front of an electronic, high-energy X-ray source operating inside a lead shield. The X-rays activate atoms of selected elements, including gold and silver. After a predetermined exposure period, the robot removes the sample and moves it to a sensitive detector which measures the activation level. This signal is then used to calculate the levels of gold, silver, and copper present. By varying the energy of the X-ray source, a wide range of different elements can be activated and measured. Each metal gives off a unique signature, meaning that multiple elements can be measured in the same sample</p>

11.6 Quality Assurance and Quality Control

11.6.1 Doyon-Westwood Property

11.6.1.1 2006–2008

The 2006–2008 drill campaign included standards sourced from Rocklabs Ltd., and internally crafted standards. Analytical results showed acceptable precision.

Blank materials were inserted, usually after a mineralized sample, in order to check for possible contamination. The laboratory’s cleaning and manipulation protocols were concluded to be generally in line with industry accepted practices, but contamination could occur when very high grade samples were assayed, particularly if visible gold was present.

A potential bias between the Doyon mine laboratory and Laboratoire Expert was noted in the 2006–2008 check assay program. The average grade of the original assays from the Doyon laboratory was 9.60 g Au/t compared with the Laboratoire Expert average of 8.47 g Au/t, which is about 12% lower than Doyon. Additional reviews showed the potential bias was restricted to the high grade assay population >40 g/t Au. For original results below 40 g Au/t, the average grade is about the same between Doyon and Laboratoire Expert. It was recommended that the resource estimators cap assay grades at 40 g/t Au.

The average grade of the original assays for gold, copper and zinc assays at the Doyon mine laboratory were similar to the average assay values returned from ALS Chemex. A difference of 9% in the average silver grade between the two laboratories was attributed to variable silver distribution in the sulphide samples.

11.6.1.2 2010–2012

Analyses completed by the Doyon laboratory included insertion of standards, blanks, and duplicate samples. At Laboratoire Expert, standards and blanks were used in the analytical stream. The exploration teams included standards, blanks, and reject duplicate samples in the sample stream sent to the laboratories.

Standards were primarily sourced from Rocklabs; however, custom standards were also created for grade matching purposes. Some of the standards were found to have been poorly mixed and had precision issues, and their use was discontinued. Review of standard analytical results showed acceptable precision. The Doyon laboratory was noted to have a minor conservative bias in the gold grades.

Blanks indicated a minor contamination issue with the Doyon laboratory. A portion of this was attributed to the blanks not being truly blank as they were sourced from drill hole samples that had assayed <0.1 g/t Au at the laboratory. The data were considered acceptable to support resource estimation as the contamination issues were well below the cut-off grade in use in the mining operations at the time.

Reject assays showed acceptable accuracy.

Check assays at Laboratoire Expert indicated slightly lower assay values being returned from the Doyon laboratory; however, the difference was considered non-material. Where larger differences occurred, the sample was found to have visible gold, and the higher-grade assay values were addressed during resource estimation by grade capping.

11.6.1.3 2013–2016

Analyses completed by Accurassay included insertion of standards, blanks, and duplicate samples, whereas Laboratoire Expert used only standards and blanks. The exploration teams included standards, blanks, and reject or pulp duplicate samples in the sample stream sent to the laboratory.

Standards were primarily sourced from Rocklabs; however, custom standards were also created for grade matching purposes. The use of in-house standards was discontinued in 2015. Laboratory precision was

considered acceptable, with Accurassay showing a slight conservative bias compared to the Rocklabs certified gold values.

Blank material continued to be sourced from drill hole samples that had assayed <0.2 g/t Au at the laboratory, and a small number of blanks reported gold grades above this value. The blank data was considered to support that limited contamination was occurring in the analytical process. Higher-grade assay values were addressed during resource estimation by grade capping.

Coarse reject data were considered acceptable, with variations between assays attributed to visible gold in the sample.

Check assays at Laboratoire Expert indicated slightly lower assay values being returned from Accurassay; however, the difference was considered non-material.

11.6.1.4 2017–2020

Analyses completed by ALS Chemex and Laboratoire Expert included insertion of standards and blanks. The exploration teams included standards, blanks, and reject duplicate samples in the sample stream sent to the laboratories.

Standards were sourced from Rocklabs, and showed acceptable precision. Slightly lower gold assay values were returned from ALS Chemex than the Rocklabs certified values.

Blank samples, consisting of barren quartzite, indicated minor contamination issues at the laboratories. Higher-grade assay values were addressed during resource estimation by grade capping.

Coarse reject data were considered acceptable, with variations between assays attributed to visible gold in the sample.

Check assays at Laboratoire Expert on samples originally assayed by ALS Chemex indicated a good correlation between the laboratories.

A check program on split duplicate material sourced from Grand Duc RC drill holes was performed in 2019 to evaluate gold grade variation in the samples. The program showed significant variation, with 23 of the 41 samples returning gold grade differences in excess of 20%.

11.6.1.5 2021–June 2024

Analyses completed by ALS Chemex and Actlabs included insertion of standards and blanks, at the rate of approximately one standard and one blank every 20 samples (5%).

Standards were sourced from Rocklab and Oreas, and showed acceptable precision. For every standard sample that was not within the ± 3 standard deviations provided by the standard certificate, re-assaying was requested for five samples before and after the standard and a new standard is sent to ALS Chemex. Results for re-assay are sent back together with the original sample assays for comparison. If sample results are similar and the second assay for the standard passes, IAMGOLD accepts the re-assay and rejects the original assay.

Blank samples, consisting of barren quartzite, indicated minor contamination, particularly after higher-grade samples had been analysed. The procedure for a blank sample that fails depend on the core type sent to ALS Chemex for analysis (full core vs half core). For half core, a re-assay is requested generally for five previous and subsequent samples from the problematic blank. The remaining half core is sent to ALS Chemex redo the sample preparation step. If the re-assayed blank does not fail, an updated certificate is requested from the laboratory. The re-assayed values are accepted, while the original ones are rejected but kept in the database. For full core, as there is no remaining material to re-start sample preparation, the laboratory is warned of the contamination, but no re-assay is requested. However, if contamination occurred during pulverization, IAMGOLD may ask for a re-assay on newly-pulverized material from the coarse reject.

Check assays at Actlabs on samples originally assayed by ALS Chemex indicated reasonable correlation between the laboratories for original pulps, coarse rejects, and pulps. The check assays are usually performed on pulp or reject material that originally assayed >1 g/t Au, and are normally undertaken on 5–10% of the original samples assayed by ALS Chemex.

Check assays completed on the photon analytical method used at MSALABS were conducted at Actlabs, using conventional analytical techniques. Of the 119 chip and muck production samples checked, all showed a good correlation between the original and check assays, even given the different analytical methods. Typically the MSALABS original assay was slightly lower than the Actlabs re-assay for the higher-grade samples.

11.6.2 Fayolle Property

11.6.2.1 Pre-IAMGOLD

Pre-IAMGOLD programs completed with Aurizon and Hecla Quebec as managers had a QA/QC program that included insertion of blank, standard, and duplicate samples in the later drill programs. Presumed gold-bearing samples from the 2006–2009 drilling programs were not grouped in specific batches. No blanks or duplicates were assayed during this time.

The field blank used in the drilling programs after 2009 was from a gold-barren sample of crushed white marble. One field blank was inserted approximately every 30 samples. QA/QC protocols required that if any blank yielded a gold value >25 ppb Au, the sample batch containing the blank was to be reassayed. Review of the blanks in the database indicated no material issues with contamination.

Standards were sourced from Rocklabs and Oreas. Insertion rates varied between drill campaigns, from 1:30 to 1:50. The quality control protocol procedures implemented by Aurizon and Hecla Quebec stipulated that if any analyzed standard yielded a gold value $\pm 20\%$ of the certified grade for that standard, then the batch containing that standard should be re-analyzed. Where re-analysis was required, the new result replaced the suspect analytical result in the database. Accuracy was generally very good.

Coarse duplicates were inserted at a 1:30 rate during 2010–2013. No duplicates were used in 2006–2009 or 2014. No significant issues with analytical precision were noted.

Check assays were completed by Techni-Lab on the 2010–2012 ALS Chemex results >1 g/t Au. The results obtained indicate an excellent reproducibility of gold values between the two laboratories.

11.6.2.2 IAMGOLD

IAMGOLD used MSALABS for analyses during the mining operations. Sample preparation and analysis were the same as used for Doyon-Westwood.

11.7 Databases

11.7.1 Doyon-Westwood Property

The software used to store drill and analytical data is acQuire. A database maintenance plan ensures that a backup of each database is made on a daily basis to prevent permanent data loss.

Data collected prior to 2013 is typically in hard copy, and converted to digital format. These paper records and logs are stored in the operations vault.

11.7.2 Fayolle Property

Aurizon and Hecla Quebec assay and drill data were stored in an Access database. IAMGOLD transferred the data from Access to acQuire subsequent to Project acquisition.

After Project acquisition, IAMGOLD verified data against original assay and survey certificates. No significant errors or issues were noted from this program. Some minor inconsistencies in data were corrected.

11.8 Sample Security

11.8.1 Doyon-Westwood Property

Core samples are collected at drilling sites and are stored in closed wooden core boxes. They are delivered to the core shack facility by the drill contractor or by the mine personnel. The core boxes are received by mine geology technicians. The core shack facilities is located at the surface, in the vicinity of the technical services offices.

The mine site is monitored by closed-circuit video cameras and has a security crew always posted at the entrance. The core shack is in an area restricted to the geology department personnel and entry is controlled via a digital key.

Typically, only selected portions of core holes are retained. These samples are stored on site at the Doyon mine, in a secured area.

Drill core rejects and pulps from significantly mineralized zones are retained on a monthly basis and can be used in re-assay and check assay programs.

11.8.2 Fayolle Property

Drill core is securely stored on standard wooden pallets in the township of Saint-Norbert-de-Mont-Brun or at the mine site.

11.9 QP Comment on Item 11 “Sample Preparation, Analyses and Security”

The QP is of the opinion that the sample preparation, analysis, quality control, and security procedures used at the Westwood and Grand Duc operations are sufficient to provide reliable data to support estimation of Mineral Resources and Mineral Reserves, and can be used in mine planning.

12 DATA VERIFICATION

12.1 Internal Verification

Internal data verification includes the use of software tools that employ a set of scripts that identify and display any inconsistent data related to Project logging rules. Picklists, look-ups, and formulae within the logging capture template help prevent missing or overlapping interval entries and entry of bad codes. Validation query sets within the database evaluate the completeness/integrity of the data set for any given drill hole within and between data tables, looking for issues such as overlapping and missing intervals, duplicate sample IDs, and distance-length validations based on the drill hole total length. Database administrators validate every import to verify that all data has been correctly imported and that no data are missing.

Additional verification by site personnel includes comparing original source data against the data in the database. Where errors or omissions were noted, these were corrected as required.

12.2 External Verification

12.2.1 Previous Technical Reports

Technical Reports were filed on the Project in 2009, 2012, 2016, and 2020. As part of the compilation of those documents, the QPs at the time reviewed the available QA/QC and supporting data. No material data issues were noted as a result of these reviews.

12.2.2 Other Reviews

In 2022, third-party consultants SLR were retained to perform a review of the Mineral Resource estimates. No material issues were identified. Recommendations from the review were incorporated into resource updates as relevant.

As the 2022 estimate was the first estimate reported where a portion of the zones were estimated using multiple-indicator kriging (MIK), an additional review was completed by Red Dot, a third-party consultant. No material issues were identified. Recommendations from the review were incorporated into resource updates as relevant.

12.3 Verification by Qualified Persons

12.3.1 Mr. Bernard Haley

Mr. Haley works at the Westwood Operations (see Section 2.4.1) and this constitutes his personal inspection.

Mr. Haley performed several reviews with the site and IAMGOLD corporate management teams in support of the Mineral Resource and Mineral Reserve estimates. The reviews included reviews of historical mining and process cost and production data, cut-off-grade calculations, life-of-mine plans, mine designs, and the Mineral Resource and Mineral Reserve estimates supporting the underground and surface operations.

In conjunction with the site management, Mr. Haley undertook reviews and discussions with aspects of site operations, environmental and safety protocols, projects, closure and reclamation planning, and social engagement with local stakeholders and communities.

As a result of the data verification, Mr. Haley considers that Mineral Resources and Mineral Reserves are supported, and the mine plan is achievable. Based on the cost estimates reviewed, the economic analysis supports Mineral Reserves.

12.3.2 Mr. Abderrazak Ladidi

Mr. Ladidi works at the Westwood Operations (see Section 2.4.2) and this constitutes his personal inspection.

He validated the Grand Duc drill hole and channel databases by performing the following checks:

- Searching the header table for duplicate hole IDs, and for incorrect collar position;
- Searching the survey table for hole IDs not matching the header table, for survey points past the hole length, and for excessive deviation in azimuth and dip;
- Searching the principal lithology table for hole IDs not matching the header table, for intervals past the hole length, for overlapping intervals, for abnormal interval lengths, and missing intervals and missing logging codes;
- Searching the remaining tables for hole IDs not matching the header table, for intervals past the hole length, for overlapping intervals, for abnormal interval lengths, and missing logging codes.

The validated Grand Duc database was considered acceptable for use in Mineral Resource estimation.

Mr. Ladidi provided grade control support, supervised the laboratory analysis process and QA/QC procedures. He also reviewed the field grade control process, aspects of geological interpretation, pit geological modeling and resource updates for the Grand Duc deposit.

As a result of this verification, Mr. Ladidi considers the resource estimate acceptable to support Mineral Reserve estimates and mine planning.

12.3.3 Mr. Martin Perron

Mr. Perron reviewed data with site personnel and IAMGOLD corporate management staff in support of the Mineral Resource and Mineral Reserve estimates. These reviews included database validation and production-related data such as the cut-off grade calculation, mined material and reconciliation of the geological model to mill production.

As a result of this verification, Mr. Perron considers the 2024 database to be valid and of sufficient quality to be used in Mineral Resource estimation.

12.3.3.1 Westwood Mine Core Drill Hole Database

The database contains data from 6,270 core holes (1,328,575.38 m) that were drilled for various purposes on the property or in the vicinity of it. Of these, 5,521 core holes (1,118,813.54 m) were drilled in the interpreted area. This selection contains 461,378 sampled intervals taken from 585,876.24 m of drilled core. All the sampled intervals were assayed for gold.

12.3.3.2 Assays

The QP had access to the assay certificates for drill holes that were drilled by IAMGOLD between 2012 and 2024. Most certificates from drill holes completed before 2012 remain available in hard copy logs (i.e., not from the laboratory). Assays were verified for selected drill holes from all the drill programs amounting to 1% of the drill holes. The selected drill holes are distributed throughout the mine and throughout time. The assays recorded in the database were compared to the original certificates or the hardcopy logs depending on the year it was drilled. No major errors or discrepancies were found.

12.3.3.3 Drill Hole Collar and Downhole Surveys

Downhole surveys (mainly Reflex surveys) were conducted on the majority of underground and surface drill holes. For holes completed between 2015 and 2024, downhole surveys are archived in the daily drilling time sheets, so the QP couldn't access the source file exports from the Reflex tool. As it was

explained to the QP, IAMGOLD's geologists import the survey data from the values entered in daily time sheets (usually entered manually by the drillers and then by the drill crew foreman) into the drillhole database; they do not use the source files. The QP would recommend using the source files from the Reflex tool to eliminate potential source of errors as it is usually done on other mine sites. Older holes (older than 2015), results were archived on hard copy logs. Downhole surveys were verified for selected drill holes from all the drill programs amounting to 1% of the drill holes. Also, a visual 3D review was completed on the drillholes traces, and no irregular deviation was observed.

Underground hole collars from drillholes completed between 2013 and 2024 were surveyed by the mine's surveyor. The source files were provided from the surveyors to the QP. Older drill holes (prior to 2013) surveyed coordinates were archived on hard copy logs. For the 1% validation of the coordinates in the surveyor's source files or the coordinates in the hardcopy logs, they were compared with the collar coordinates found in the database. No major discrepancies were found.

12.3.4 Mr. Louis Nkoy Manda Mbomba

Mr. Louis Nkoy Manda Mbomba works at the Westwood Operation (see Section 2.4.3).

He performed a number of reviews in support of the Mineral Reserve estimates, mine designs, and capital and operating cost assumptions for the open pit and underground mine plans that included: open pit design parameters and pit stages; underground stope design parameters and mining sequence; haul roads; underground accesses; pit shells, DSO shapes, and optimization of the mine plans; reconciliation performance; equipment numbers, utilization rates, and maintenance strategy; consumables costs; sustaining capital and operating costs; and sensitivity of costs to key input parameters. Mr. Nkoy considers that a reasonable level of verification has been completed and that no material issues have been left unidentified from the programs undertaken. The data are acceptable to be used in Mineral Reserve estimation and mine planning.

12.3.5 Dr. Ali Jalbout

Dr. Jalbout has performed site visits (see Section 2.4.4).

He has been working at the Westwood Operations since March 2020, firstly as an IAMGOLD employee until November, 2021, then as an independent consultant. While on site, he is the geotechnical specialist at the mine.

Dr. Jalbout put in place all the geotechnical procedures and geotechnical standards since November, 2020.

He performed several reviews with site and IAMGOLD corporate management teams in support of the geotechnical considerations related to the underground mining at the Westwood mine. This work included reviews of historical geotechnical events and the different failure mechanisms that might occur at the Westwood mine, and the mitigation plan that has to be put in place in order to mitigate these geotechnical hazards.

Dr. Jalbout also reviewed geotechnical interpretations with staff, supervised the geotechnical analyses that include ground support designs, stress modeling, seismic analysis, QA/QC, auditing, and due diligence.

Following these reviews, Dr. Jalbout considers the geotechnical data and interpretations sufficient to support the LOM plan.

12.3.6 Mr. Steve Pelletier

Mr. Pelletier has performed site visits (see Section 2.4.5).

He reviewed the environmental management system and the Permitting and Social or Community Relations Plan with site personnel and IAMGOLD corporate management staff. The reviews included closure plans, environmental results database, and reports, permits compliances, regulations compliances, permitting public consultations, and discussion with the Indigenous on cooperation agreement.

As a result of this reviews and verification, Mr. Pelletier considers the Environmental management system, permitting strategy and Social or Community relations plan in place are adequate to support the LOM plan.

13 MINERAL PROCESSING AND METALLURGICAL TESTING

13.1 Introduction

The Doyon, Mouska and Fayolle deposits are mined out, and the metallurgical testwork completed over these deposits is no longer relevant to the Project.

The process plant has been treating ore since the 1980s, and specifically treating ore from Westwood since 2013; as such the metallurgy is well understood.

Metallurgical testwork has been conducted by a number of independent laboratories and third-party consultants over the Project life. These include the laboratories SGS-Lakefield in Ontario, Laboratoire du CEGEP de l'Abitibi-Témiscaminque, COREM and the Unité de recherche et de service en technologie minérale in Quebec, and the Doyon mine laboratory and process plant. There is no international standard of accreditation provided for metallurgical testing laboratories or metallurgical testing techniques.

Work completed included chemical analysis (inductively-coupled plasma (ICP) optical emission spectroscopy, ICP mass spectrometry, whole rock analysis), mineralogy (QEMSCAN), comminution (Bond ball mill work index (BWi), Bond abrasion index (BAi), Miller number abrasivity tests), gravity recoverable gold tests, cyanide index tests, carbon-in-leach (CIL) tests, bulk sample testwork, cyanide destruction testwork, and acid base accounting (ABA) and net acid generation (NAG) testing.

13.2 Gold Metallurgical Testwork

BWi and abrasion tests showed the Westwood ores to be soft to average in hardness, ranging from 7.6–14.1 kWh/t, averaging about 11.1 kWh/t. Ore was amenable to gravity recovery from the grinding circuit, with results ranging from 19–79% gravity recoverable gold. Gold recovery results from cyanide leaching ranged from 81.6–95.7% with an average of 89.8%. Actual Doyon plant results (including gravimetry and carbon absorption) demonstrated better overall performance than the average performance obtained in the laboratory tests.

BWi and abrasion tests showed the Grand Duc ores to be hard, with an average BWi of 14.2 kWh/t, ranging from 11.1–18.1 kWh/t. Gold recoveries from whole ore leaching were acceptable at 90.0%, with an average retention time of 52 hours. Cyanide consumption for Grand Duc ore was observed to be much lower than for Westwood ore due to its lower sulphide content.

13.3 Zinc and Copper Metallurgical Testwork

A preliminary test program was completed to determine zinc and copper recovery from the Warrenmac deposit area in 2020. Copper–zinc flotation locked cycle tests were conducted to simulate plant operations. Locked cycle testing projected a copper concentrate grading 26% Cu at 86% recovery, and a zinc concentrate grading 58% Zn at 89% recovery. In the copper concentrate, gold recovery was 71% and silver recovery was 56%.

Batch flotation tests were performed on samples from the WW25 lens, and the best parameters were subsequently used to perform a locked cycle test. The zinc circuit produced a marketable zinc concentrate grading 55% Zn at a recovery of 91%. The copper/lead concentrate contained 65% to 70% Cu and Pb units, albeit at a relatively low grade due to the iron sulphide contamination. A total of 85% of the gold and 63% of the silver reported to the copper/lead concentrate. Gold and silver recoveries from whole ore leaching were acceptable at 92.2% and 76.2%, respectively. Although the gold and silver recoveries from the combined zinc tailings were lower than in the leach circuit, the overall extraction into the copper concentrate and the pregnant solution was 90.3% and 75.5%, respectively, and therefore comparable with the whole ore test results. The quality of the copper concentrate was 9% Cu, with 85% Au released at this stage. The concentrate is not considered a marketable product and would require further upgrading.

Testwork has been completed to address closure considerations, which involved sulphur flotation to produce non-acid tailings. The testwork aim was to produce non-acid tailings that could be used for revegetation purposes and potentially a saleable sulphur product. Testwork was conducted by the Unité de Recherche et de Service en Technologie Minérale de l'Université du Québec en Abitibi-Témiscamingue. The testwork objectives could not be achieved, and no additional work is planned.

13.4 Recovery Estimates

The results of the metallurgical test programs indicate that the ore types tested from Westwood and Grand Duc are amenable to CIL methods.

The process plant has reasonably consistently achieved gold recoveries of > 92%. In 2021, when lower head-grade material was treated, the recovery averaged 91.5%.

The current life of mine (LOM) plan assumes an average gold recovery of 95% for Westwood, and 90% for Grand Duc.

13.5 Metallurgical Variability

Samples selected for metallurgical testing during feasibility and development studies were representative of the various styles of mineralization within the different deposits. Samples were selected from a range of locations within the deposit zones. Sufficient samples were taken and tests were performed using sufficient sample mass for the respective tests undertaken.

Samples are currently selected for each zone, using a grade-tonnage table, and used for mine-to-mill testing. Tests include BWi and bottle roll tests, and are performed using the existing plant parameters to confirm the amenability of the ores in the life-of-mine plan to treatment through the process plant.

13.6 Deleterious Elements

There are no known deleterious elements in the LOM plan that would be expected to affect metallurgical recoverability or product saleability.

Table 13-1: Comminution Testwork Result Ranges

	DWi (kWh/m ³)	DWi (%)	Mi Parameters			SG	A	b	A*b	Ta	SCSE (kWH/t)
			Mia	Mih	Mic						
Range	5.7–7.7	37–64	16.2–22.1	11.6–16.8	6–8.7	2.66–2.83	69.5–88.8	0.39–0.72	34.6–37.3	0.34–0.46	9.15–10.48

Note: Dwi = drop weight index; Mia = coarse ore work index; Mih = high-pressure grind roll ore work index; Mic = crushing ore work index; SG = specific gravity; A and b = ore impact breakage parameters from drop weight tests; Ta = abrasion parameter from drop weight test.

14 MINERAL RESOURCE ESTIMATES

14.1 Westwood

14.1.1 Introduction

The close-out date of the Westwood database is 14 November, 2023. The Mineral Resource estimate is based on 6,270 core drill holes (1,328,575.38 m) drilled from surface and underground between 1938–2024. This selection contains 476,368 sampled intervals taken from 600,323.71 m of drilled core. No muck or channel samples were used in the estimation, and no channel samples were used to model mineralized lenses.

The estimate was prepared using Leapfrog Geo software version 2023.2.0 (Leapfrog) for the 3D mineralization model and Isatis.neo 2024.04 (Isatis) for the grade estimation and block modelling. Basic statistics, capping and validations were established using a combination of Isatis, Microsoft Excel, and Python scripts.

One block model was constructed for the entire Westwood deposit. The 3D wireframes of the mineralization lenses, the buffers, and the completed underground excavations (as at 30 April, 2024) act as sub-block triggers for their coding. The block model uses a parent block size of 4 x 1 x 4 m, sub-blocked to 1 x 0.5 x 1 m.

14.1.2 Structure Review

A study of the structurally-controlled mineralized shoots was undertaken to assess the reproducibility of the known gold-bearing structures within the drill hole database. The findings demonstrate the presence of north–south-trending, east-dipping, gold-enriched structures that are not well represented in the database (Figure 14-1). These structures are sub-parallel to the main drilling direction, and their under-representation causes interpolation bias in the higher grades.

14.1.3 Models and Domains

The mineralization model was built by IAMGOLD geologists and validated by the QP using the drill hole database as the primary source of information. This contained information on assays, lithological units, alteration, and mineralization. The model was based on the previous iteration of IAMGOLD’s modelled mineralization, geology, alteration corridors, and major structures.

Figure 14-1: Stereonet Representation, Structurally Controlled Mineralized Shoots Inside Schistosity Planes

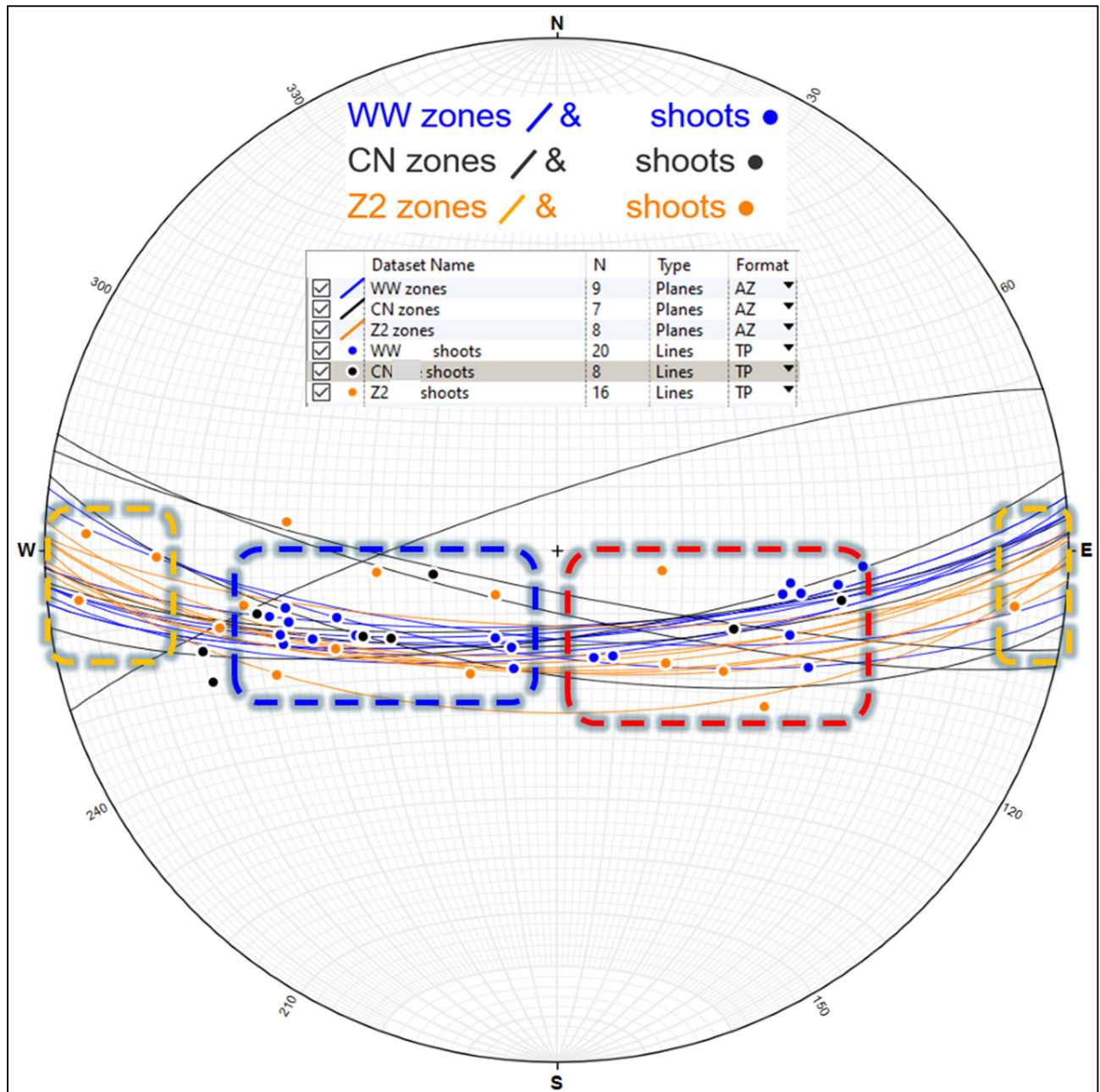

Note: Figure prepared by InnovExplo, 2024. The blue dashed box represents the known stretching lineations, and the yellow dashed box represents the known crenulation cleavages. The red dashed box represents structural measurements underrepresented in the database.

The mineralization model consists of 128 mineralized lenses grouped into three corridors, Corridor North (CN), Westwood (WW) and Zone 2 Extension (Z2 Ext) designed without a minimum thickness (i.e., using the true thickness of the mineralized lenses) and are, therefore, not diluted. The mineralized lenses were modelled over the extent of the logged geological control(s) that are characteristic to each zone, as described in Section 7 (i.e., quartz-carbonate veining, strong brecciation, high pyrite content, strong sericite alteration, etc.) and snapped to assays, without a geological cut-off grade, in favour of geological continuity. For drill holes without descriptions, modelling was guided by the gold grades using a 2.0 g/t Au cut-off grade. These lenses were used as interpolation domains.

A 10 m buffer was generated in Leapfrog around the mineralized lenses in each corridor, and these buffer zones were used as domains to interpolate dilution.

The modelled Bousquet Fault truncates the mineralized lenses and buffers.

IAMGOLD prepared and provided wireframes of underground excavations (as at 30 April, 2024). These were used to code the block models for the mined-out portions of mineralized lenses. Mined-out voids from September 2024 were mathematically removed from the Mineral Resource statement.

14.1.4 Capping

Mineralized veins were grouped by comparing χ^2 statistics between the veins. The chi-square distance was used to determine the distance between two different category distributions of a specific attribute as the following:

$$\sum_{i=1}^n \frac{(x_i - y_i)^2}{(x_i + y_i)}$$

The variables x_i and y_i represent the frequency of category i for elements x and y , and thus are suitable to be used to measure the similarities between category attributes, such as mineralization type.

Four attributes, alteration type, alteration style, mineralization type, and percentage of sulphide (pyrite) were combined to define the distance between two different veins. Hierarchical clustering was carried out on the veins for each mineralized corridor based on the chi-square distance. Considering the large number of composites, a threshold was determined for each corridor to select certain representative vein groups. The remaining veins were assigned to their nearest respective groups (i.e., the shortest distance to a representative group).

The lenses in the CN corridor were assigned to a single group, A. The lenses in the WW corridor were divided into groups B and C, and the lenses in the Z2 Ext corridor were divided into three groups, E, F, and G. The buffered areas for CN, WW, and Z2 Ext were designated as groups H, I, and J.

Basic univariate statistics were generated. The mineralized lenses were grouped by similar lithological, structural, and mineral characteristics.

The high-grade capping was performed on each group of veins separately. Capping values were selected by combining the dataset analysis of these groups (coefficient of variation, decile analysis, metal content) with the probability plot and log-normal distribution of grades inside those groups. Capping was applied to raw assay values.

Table 14-1 presents the raw assay statistics. Table 14-2 presents the grade capping values. Figure 14-2 shows example graphs supporting the capping value for the E lens group.

14.1.5 Compositing

The capped gold assays of the drill hole data were composited to 1.0 m lengths in each of the mineralized lenses and buffers to minimize any bias introduced by variable sample lengths. The thickness of the lenses, the proposed block size and the original sample lengths were all considered when determining the composite length. The minimum width of more than 1/3 of the veins is <0.5 m. The residuals of length >0.3 m were retained in the composites to keep more valid composites inside the veins, while the tails <0.5 m were spread to all the composites. Compositing was applied to both capped and uncapped assays, as the multiple-indicator kriged (MIK) interpolation was carried out on uncapped composites and ordinary kriging (OK) interpolation used capped composites. Unsampled drill holes were ignored. A total of 332,024 composites were generated and used for block model grade estimation.

For the MIK method, the same compositing rules were applied to uncapped gold assays to generate a composite table for interpolation.

Table 14-3 and Table 14-4 present the statistics for the uncapped and capped gold composites, respectively.

Table 14-1: Gold Assay Statistics

Corridor	No. of Samples	Min.	Max.	Mean	Median	SD	CoV
North Corridor	4,104	0.00	848.15	4.86	1.81	20.75	4.27
Westwood	7,381	0.00	1,763.5	6.44	2.14	32.98	5.12
Zone 2 Ext.	17,498	0.00	3,772.05	13.47	2.07	67.46	5.01

Note: Min. = minimum; Max = maximum; SD = Standard deviation; CoV = coefficient of variation

Table 14-2: Grade Capping Values

Corridor	Group	Capping Value (g/t Au)	Lenses
North	A	75	All CN lenses
Westwood	B	100	WW17D and WW25D, WW25E, WW25F
	C	140	All other WW lenses
Zone 2 Ext.	E	200	Z249A, Z251A, Z253A, Z259A
	F	250	All other Zone 2 Ext lenses
	G	500	Z245A, Z256A, Z258A, Z262AB, Z270B, Z270D, Z271A, Z280A, Z284A and Z294A
CN Buffer	H	20	All around the CN lenses
WW Buffer	I	20	All around the WW lenses
Z2 Ext Buffer	J	10	All around the Z2 Ext lenses

Figure 14-2: Example Capping Analysis, Group E

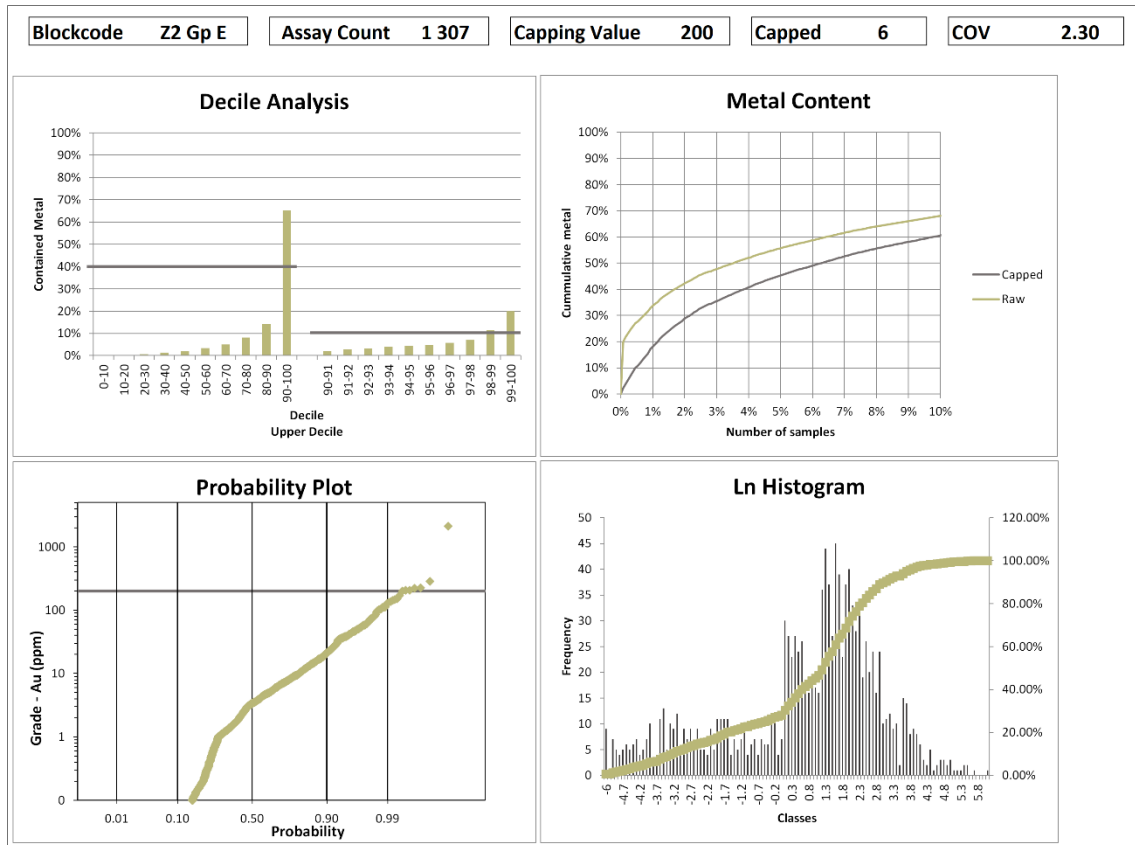

Note: Figure prepared by InnovExplo, 2024.

Table 14-3: Uncapped Gold Composite Statistics

Zone	No. of Composites	Min.	Max.	Mean	Median	SD	CoV
Zone 2 Ext.	20,641	0	3,772.05	11.96	1.49	63.92	5.35
North Corridor	5,400	0	848.15	4.48	1.70	19.68	4.39
Westwood Corridor (veins)	8,535	0	1,168.49	5.62	1.84	24.85	4.42
Buffer Z2	194,310	0	968.60	0.30	0.07	2.86	9.62
Buffer NC	34668	0	139.00	0.53	0.23	1.54	3.10
Buffer WW	68,471	0	1,004.27	0.57	0.24	4.24	7.44

Note: Min. = minimum; Max = maximum; SD = Standard deviation; CoV = coefficient of variation

Table 14-4: Capped Gold Composite Statistics

Zone	No. of Composites	Min.	Max.	Mean	Median	SD	CoV
Zone 2 Ext.	20,641	0	500	10.01	1.49	29.50	2.94
North Corridor	5,400	0	75.00	3.75	1.70	8.15	2.17
Westwood Corridor (veins)	8,535	0	140	4.84	1.84	11.30	2.33
Buffer Z2	194,310	0	20.00	0.26	0.07	0.67	2.56
Buffer NC	34668	0	20.00	0.51	0.23	0.95	1.87
Buffer WW	68,471	0	10.00	0.53	0.24	1.04	1.96

Note: Min. = minimum; Max = maximum; SD = Standard deviation; CoV = coefficient of variation

14.1.6 Density

Density was measured by the immersion method (refer to Section 11.2).

The data shows a general tendency to take a greater number of measurements in the more sulphide-rich veins. As a result, the density analysis for a given lens may not be representative of all its mineralized zones in their entirety. However, because sulphide contents and mineralization types were taken into account when grouping the mineralized lenses, the density measurements were grouped according to the same scheme to yield averages. The assumption that the mineralized material in each group shares similar characteristics is reasonable and consistent with the grade and tonnage estimation.

Table 14-5 shows the calculated density average for each group.

14.1.7 Variography

14.1.7.1 Ordinary Kriging

The QP opted to perform a variographic analysis of capped composites for each corridor (CN, Westwood, and Zone 2 Ext) to optimize the data for OK interpolation. The same variographic parameters were applied to all groups of mineralized lenses in a given corridor (refer to discussion in Section 14.1.3).

The orientation of the variogram model for each corridor was locally corrected in order to better represent the spatial reality, including the main gold shoot, of the different mineralized lenses.

Table 14-5: Density by Group of Mineralized Lenses and Buffers

Corridor	Group	Number of Samples	Density (g/cm ³)
North	A	116	2.9
Westwood	B	470	3.7
	C	1,222	3.1
Zone 2 Ext.	E	87	3.0
	F	673	3.0
	G	16	3.1
CN Buffer	H	710	2.8
WW Buffer	I	8,774	2.9
Z2 Buffer	J	4,569	2.9

For each group inside of the CN, WW and Z2Ext corridors, all the composites within that group were used for variogram analysis. In particular, the composites pairs used to derive the experimental variograms were confined to each mineralized lens within that group. This prevented the sample pairs from crossing the boundaries of the mineralized lenses while maximizing the data utilization for the group.

A variography study was also completed on the 10 m envelope surrounding the mineralized solids to properly represent the geological dilution.

Figure 14-3 shows the variography study for the F group of mineralized lenses as an example.

14.1.7.2 Multiple Indicator Kriging Interpolation

The interpolation method was set to MIK in domains with a sufficient number of composites. MIK is a non-linear method that breaks any population that does not follow a normal statistical behaviour into different independent individual groups of grades that are more prone to following normal statistical methods. The MIK method was preferred because it better represents the variability of the high-grade assays in the dataset and better aligns with the mine-to-mill reconciliation.

The QP selected only lenses with sufficient data and historical mine-to-mill reconciliation for the MIK modelling. None of the lenses in the North Corridor were considered, as no mine-to-mill reconciliation data were available for this corridor.

Figure 14-3: Variography Study for Group F

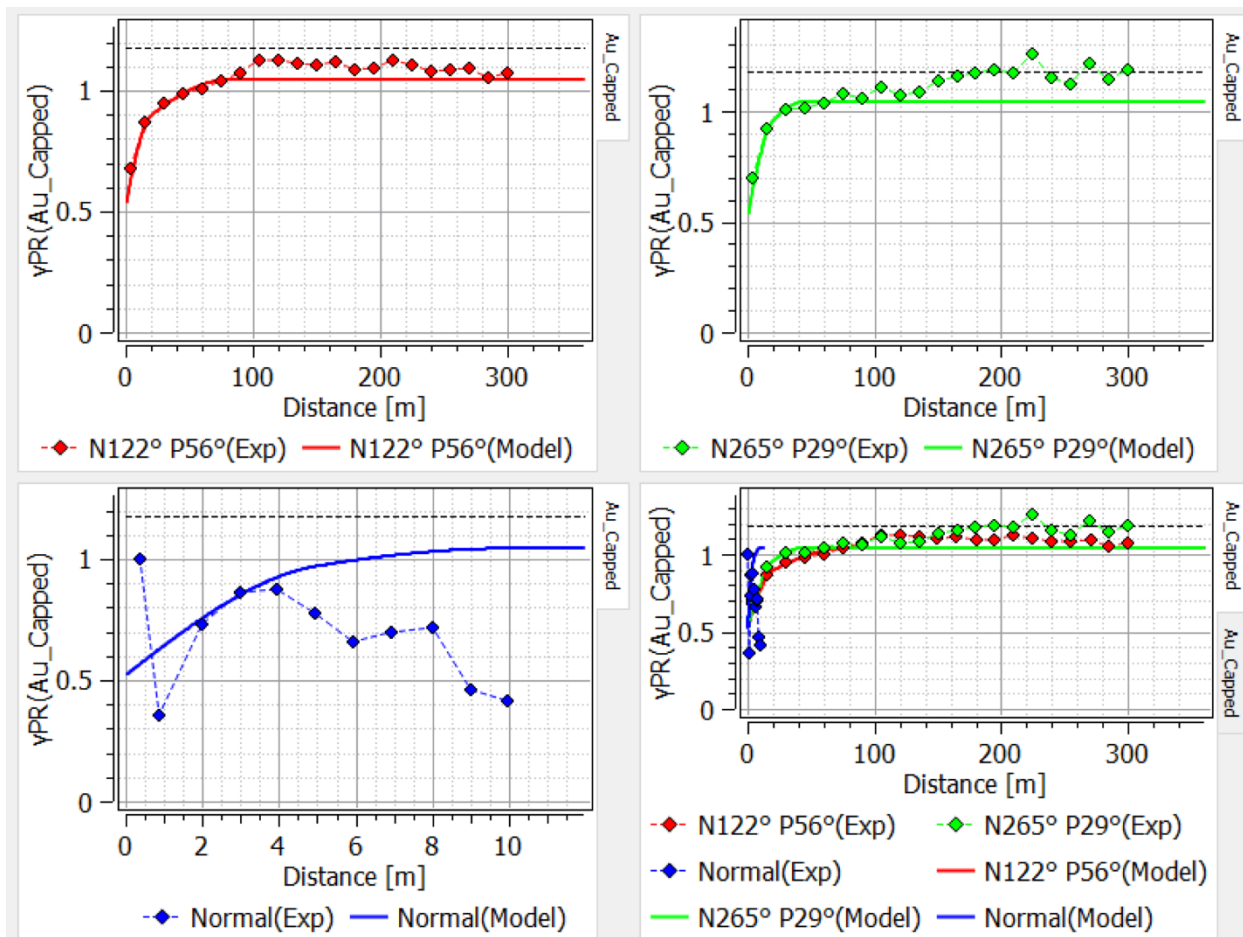

Note: Figure prepared by InnovExplo, 2024.

For the Westwood corridor, six lenses fulfilled the criteria for MIK interpolation: WW10A (rock code 201), WW23A (rock code 213), WW27A (rock code 217), WW28A (rock code 220), WW28B (rock code 221) and WW28C (rock code 222). Lenses WW28A, WW28B, and WW 28C were combined for indicator variogram analysis because there were insufficient composites in the last two lenses to perform reasonable interpretations.

For the Zone 2 Ext corridor, seven lenses also fulfilled the criteria for MIK interpolation: Z226A (rock code 314), Z230A (rock code 320), Z230B (rock code 321), Z233A (rock code 324), Z234A (rock code 325), Z234C (rock code 327) and Z260A (rock code 351).

Ten to 12 thresholds were determined for each vein to create indicator variables and generate a probability distribution for each estimation node. The expected value from this probability distribution was used as the MIK result. The thresholds were generally selected based on the grades and metal contents of the declustered samples. In principle, the thresholds in the higher grades tend to be more towards the deciles of the metal contents.

Table 14-6 and Figure 14-4 show the selected thresholds for WW28A, as an example.

Figure 14-5 shows the modelling of the major axis of the WW28A semi-variogram for cut-off #1. Table 14-7 shows the cut-off thresholds for all lenses selected for MIK interpolation.

14.1.8 Grade Interpolation

Each domain (mineralized lens or buffer) was estimated independently as a hard boundary using the capped composite gold grades for OK interpolation and the uncapped composites for MIK interpolation.

Mineralized lenses selected by the QP for MIK interpolation (documented reconciliation data) used their MIK result as the gold value (block model attribute "Au_Final"). Other mineralized lenses where MIK criteria could not be met used the OK interpolation as the final value. The block model attribute "Au_Final" was used to optimize conceptual mining shapes using Deswick Stope Optimiser (DSO) software, and the final Mineral Resource statement.

The mineralized lenses using the MIK interpolation as the final gold value are: WW10A (rock code 201), WW23A (rock code 213), WW27A (rock code 217), WW28A (rock code 220), WW28B (rock code 221), WW28C (rock code 222), Z226A (rock code 314), Z230A (rock code 320), Z230B (rock code 321), Z233A (rock code 324), Z234A (rock code 325), Z234C (rock code 327) and Z260A (rock code 351).

14.1.8.1 Ordinary Kriging

The OK variography study provided the parameters for interpolating the grade model using point datasets corresponding to the mid-points of composited intervals. A three-pass strategy was used.

The remaining high gold values, constrained by the dilution buffers, used a restricted search to reduce the smearing of high values (>1 g/t Au) over large distances.

The grade estimation parameters specific to Isatis are summarized in Table 14-8.

Table 14-6: MIK Cut-off Thresholds for WW28A (rock code 220)

Cut-off	Thresholds	Grade Percentiles	Metal Percentiles	Number of Samples
1	0.28	20	0.57	1395
2	1.11	40	3.47	1078
3	2.1	57.68	10	794
4	3.5	71.69	20	598
5	5.41	80.27	30	426
6	7.22	86.64	40	322
7	11.38	91	50	205
8	15.24	93.87	60	133
9	22.3	96.41	70	71
10	25.6	98.21	80	47
11	48.8	99.37	90	16

Figure 14-4: Metal-Grade Percentile Plot of WW28A Showing Cut-Off Thresholds

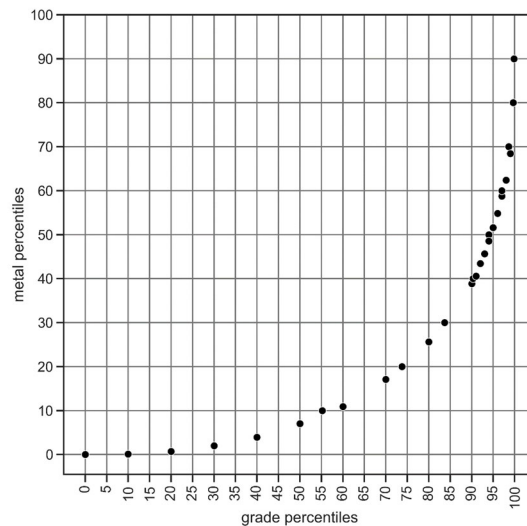

Note: Figure prepared by InnovExplo, 2024.

Figure 14-5: Semi-Variogram Of Cut-Off #1 As An Example (WW28A)

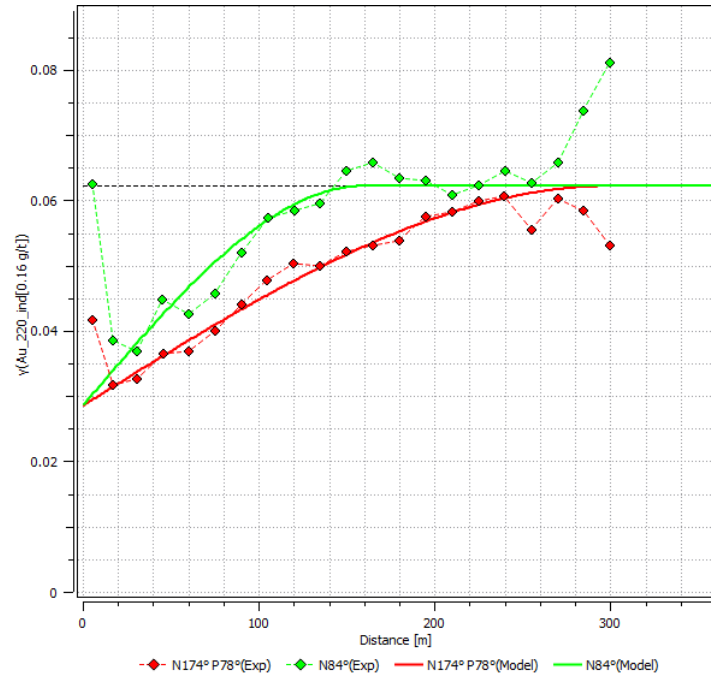

Note: Figure prepared by InnovExplo, 2024.

Table 14-7: MIK Cut-Off Thresholds For All Selected Lenses

Threshold	Rock Code												
	201	213	217	220	221	222	314	320	321	324	325	327	351
1	0.48	0.2	0.33	0.28	0.28	0.28	0.23	0.4	0.46	0.5	0.3	0.07	0.13
2	1.31	1.01	1.27	1.11	1.11	1.11	2.43	2.44	2.47	3.54	1.4	0.4	1.14
3	2.03	2.57	2.86	2.1	2.1	2.1	8.88	6.13	6.88	6.75	4.53	1.37	3.14
4	3	6.68	3.74	3.5	3.5	3.5	18.22	10.65	11.28	11.99	8.23	3.24	5.83
5	4.59	17.7	4.78	5.41	5.41	5.41	26.7	19.91	21.4	16.36	17.5	11.06	14.4
6	7.52	53.46	6.44	7.22	7.22	7.22	43.45	25.29	30.29	25.32	27.09	19	29.3
7	12.22	90.63	9.45	11.38	11.38	11.38	70	41.41	69.33	32.25	43.79	31.4	55.66
8	17.15		16.1	15.24	15.24	15.24	98.72	66.08	106.3	46.84	74.39	41.5	105.07
9	30.47		22.21	22.3	22.3	22.3	135.1	96.61	129.27	61.94	121.94	59.3	166.63
10	40.81		41.02	25.6	25.6	25.6	212.59	120	235	82.64	288.31	104.5	289
11				48.8	48.8	48.8	340.5	181.98		139.92			
12								295.07					

Table 14-8: Estimation Parameters

Domain Type	Search Ellipse Name	Ranges (based on variography)			Composite Parameters			Restricted Search	
		Major (m)	Semi.	Minor	Min. No. Comp	Max. No. Comp	Max. Comp. per Drill Hole	Distance (m)	Value (g/t Au)
Lens	P1	50	50 m x Semi_Range/Major_Range	50 m x Minor_Range/Major_Range	5	8	2	N/A	N/A
	P2	75	75 m x Semi_Range/Major_Range	75 m x Minor_Range/Major_Range	3	8	2	N/A	N/A
	P3	100	100 m x Semi_Range/Major_Range	100 m x Minor_Range/Major_Range	3	8	2	N/A	N/A
Buffer	P1	50	50 m x Semi_Range/Major_Range	50 m x Minor_Range/Major_Range	5	8	2	40	1
	P2	75	75 m x Semi_Range/Major_Range	75 m x Minor_Range/Major_Range	3	8	2	40	1
	P3	100	100 m x Semi_Range/Major_Range	100 m x Minor_Range/Major_Range	3	8	2	40	1

14.1.8.2 Multiple Indicator Kriging

MIK interpolation was completed for each threshold determined within a specific grade distribution. For all unique blocks within a mineralized lens domain, OK interpolation was applied to all the independent threshold subset data using the results of each individual variography study. A grade was then estimated for each threshold using composites spatially associated with the block. The final estimated grade for each unique block is a summation of individual threshold OK results weighted by the frequency of occurrence of these thresholds in the cumulative frequency plot of the mineralized lens dataset.

The advantage of this interpolation technique was that the metal factor associated with each threshold can be adjusted to correct for mine-to-mill discrepancies to address the sampling bias. This was achieved by adjusting the upper tail distribution of the higher grades.

Median values were used to represent the grade between two thresholds and generate the expected value from the distribution as the MIK interpolation result. However, this cannot be applied to the last threshold as no upper bound is specified. Instead, the sample median or sample average above the last threshold can be used. Note that this is often unreliable as the number of samples is relatively low compared to the other thresholds. Instead of explicitly specifying a cut-off value, the upper tail distribution was characterized by a hyperbolic model using the following equation (c.f., Deutsch and Journel, 1997, p. 137):

$$F_{\omega,\lambda}(z) = 1 - \frac{\lambda}{z^\omega}, \omega \geq 1, z^\omega > \lambda > 0$$

The coefficient λ can be determined by the last threshold and its probability. The coefficient ω is left to control the behaviour of the upper tail distribution. In general, the smaller the coefficient ω , the higher the proportion attributed to the high grades, leading to higher expectations above the last threshold.

Among the total 169 stopes excavated on 22 veins that were available for reconciliation review, 36 new stopes were added in 2024. The increasing numbers of stopes brings extra difficulty to global and local reconciliation with the production data. An observation is that biased sampling exists in various gold grade ranges. The adjustment on the tail distribution affects the proportion of the highest grades but has little impact on middle grades. Hence, an additional power distribution was introduced to model the in-class distribution between two thresholds z_i and z_{i+1} using the following equation:

$$F(z) = F(z_i) + \left(\frac{z - z_i}{z_{i+1} - z_i} \right)^\alpha (F(z_{i+1}) - F(z_i))$$

This additional parameter α allows tuning of in-class expectations of grades between two adjacent thresholds. In general, higher α leads to higher in-class expectation. Moreover, if α equals 1, the model reduces to the conventional linear model that represents the mid-point of the interval. If α moves from 1 towards 0, then the expectation shifts to the lower end of the interval. Vice versa, if α moves beyond 1, the expectation shifts to the higher end of the interval. This offers the flexibility to prevent the reconciliation from both underestimation and overestimation.

Several iterations were performed to optimize the choice of parameters ω and α to adjust the weight of the higher-grade composites, thus eliminating the sampling bias and achieving better reconciliation results.

Several iterations were performed to optimize the choice of parameter λ to adjust the weight of the higher-grade composites, thus eliminating the sampling bias and achieving better reconciliation results.

Table 14-9 presents all the determined coefficients for the upper tail distributions of the higher grades.

Mine-to-mill reconciliation is discussed in Section 14.1.12.

14.1.9 Block Model Validation

The QP performed visual and statistical validation to ensure that the final mineral resource block model was consistent with the primary data.

The volume estimates attributed to each code by mineralized zone were compared between the block model and the three-dimensional wireframe models. No issues were observed.

Additionally, interpolated grades (OK or MIK, where possible), composite grades, and assays were visually compared on longitudinal views for densely and sparsely drilled mineralized areas. In general, the effect of smoothing using OK is more pronounced compared to the local variations of other methods. MIK allows interpolation at higher grades than OK. As expected, MIK-interpolated grades are usually higher than those by OK, which is the desired effect.

Swath plots and cumulative histograms were produced to statistically compare the composites to the interpolations.

Table 14-9: Optimizing Coefficients for the MIK Lenses

Rock Code	Lens	ω	α
201	WW10A	2	1
213	WW23A	1.5	2
217	WW27A	2	1
220	WW28A	3	2
221	WW28B	3	1
222	WW28C	3	1
314	Z226A	2.6	3
320	Z230A	2	1
321	Z230B	2	1
324	Z233A	2	2
325	Z234A	2	3
327	Z234C	1.5	3
351	Z260A	4	0.5

Figure 14-6 demonstrates the representativity of the sample data provided by MIK compared to OK, with Z230A (rockcode 320) as an example. The mean value of the sample data is 12.58 g/t Au, with a standard deviation of 31.41. MIK was able to reproduce it with a mean value of 13.15g/t Au and a standard deviation of 26.40. OK was lower with a mean value of 11.06 g/t Au and a lower standard deviation of 14.82.

The results demonstrate OK's ineffectiveness in reproducing the sample data mean value, and the very low standard deviation indicates a strong smoothing of the interpolation compared to the sample data. MIK was able to achieve better representation in the interpolation of the sample data parameters.

Figure 14-7 compares the composite gold grades to the block grades for each method using Z230A as an example.

Figure 14-6: Comparison of the Mean Grades for Sample Data (A), MIK (B) and OK (C) for Mineralized Lens Z230A (rockcode 320)

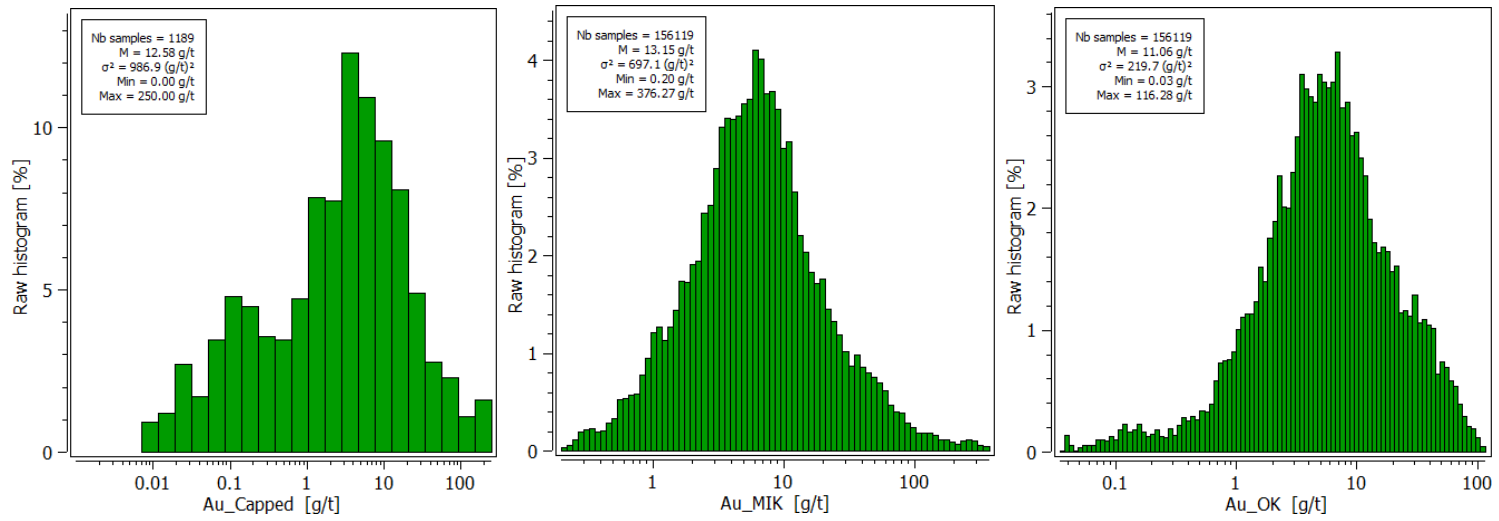

Note: Figure prepared by InnovExplo, 2024.

Figure 14-7: Comparison of Composite Gold Grades to Block Grades (MIK and OK interpolation) for Mineralized Lens Z230A (rock code 320)

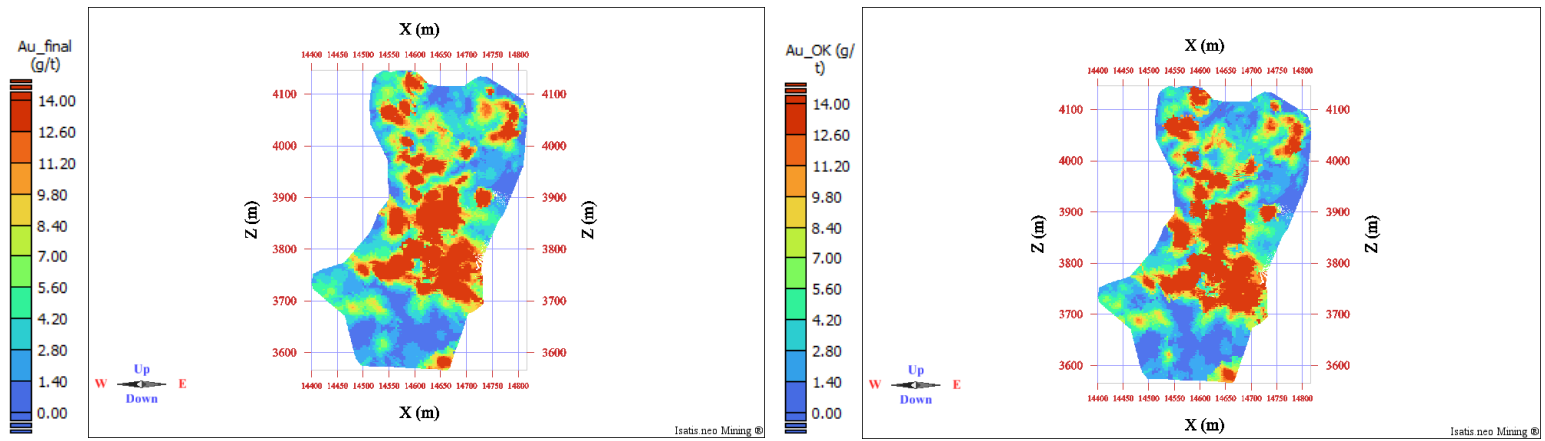

Note: Figure prepared by InnovExplo, 2024.

14.1.10 Confidence Classification

The confidence categories were assigned using a constraints script in Isatis.

A smoothing window subsequently refined the resulting classifications to upgrade Inferred blocks or downgrade Indicated blocks locally in some mineralized lenses, as needed. The Measured Mineral Resources from the original classification were not smoothed to prevent downgrading the classification. The QP considers this a necessary step to homogenize the Mineral Resource volumes in each category and avoid including isolated blocks in the Indicated category.

The classification took into account the following criteria:

- Distance to closest information;
- Confidence in the geological interpretation;
- Continuity of the geological structure and the grade within this structure;
- Interpolation pass.

The Measured category was assigned to blocks estimated with a minimum of two drill holes in areas where the distance from a drill hole was <15 m and within 10 m of an underground opening in a mineralized zone.

The Indicated category was assigned to blocks estimated with a minimum of two drill holes in areas where the distance from a drill hole was <15 m.

The Inferred category was assigned to blocks estimated in areas where the distance from a drill hole was <75 m.

In addition to the employed confidence criteria, Mineral Resources are constrained within potentially mineable shapes to demonstrate reasonable prospects for eventual economic extraction. Regarding the potentially mineable shapes resource classification, the dominant system ensured that all resources were associated with one of the evaluated categories (Measured, Indicated, or Inferred). The category of each potentially mineable shape was dictated by the most prominent category by volume in each shape.

14.1.11 Reasonable Prospects of Eventual Economic Extraction

14.1.11.1 Constraining Mineable Shapes

Constraining volumes were produced using DSO software with a minimum mining shape of 13 m along the strike of the deposit, a height of 25 m and a minimal width of 2.4 m. The maximum and typical shapes measure 13 m x 30 m x [lens width], where development did not occur. The typical shape size was optimized first. If it was not potentially economical, a smaller stope shape was optimized using the same cut-off grade but with various sub-shape scenarios. Fifteen sub-shape scenarios were created to maximize block model representativity. Table 14-10 enumerates these scenarios. This cut-off grade was used for Measured, Indicated and Inferred Mineral Resources. Blocks outside the interpreted mineralized zones were estimated only if they fell inside the buffer zone.

The DSO results were used to constrain the Mineral Resource estimate.

The use of conceptual mining shapes as constraints to report underground mineral resources helps satisfy the criterion of *'reasonable prospects for eventual economic extraction'* as defined in the 2014 CIM Definition Standards and the 2019 CIM Best Practice Guidelines.

14.1.11.2 Cut-Off Grade

Cut-off grade parameters were determined using the parameters presented in Table 14-11. IAMGOLD uses cut-off grades for their Mineral Resource estimates based on corporate guidelines regarding gold price, exchange rates, and long-term cost estimates.

The Mineral Resource estimate is reported at a cut-off grade of 5.7 g/t Au for both the MIK and the OK methods.

The QP considers the selected cut-off grade of 5.7 g/t Au is adequate based on the current knowledge of the Project and supports that the Mineral Resource estimates have reasonable prospects for eventual economic extraction for an underground mining scenario.

Table 14-10: DSO Sub-Shape Scenarios

Scenario	Minimum Horizontal Variation	Maximum Horizontal Variation	Minimum Vertical Variation	Maximum Vertical Variation	Grade Multiplier
1	0	0.5	0	1	1
2	0.5	1	0	1	1
3	0	1	0	0.8	1
4	0	1	0.2	1	1
5	0	1	0	0.6	1
6	0	1	0.4	1	1
7	0	1	0	0.4	1
8	0	0.5	0	0.8	1
9	0	0.5	0.2	1	1
10	0	0.5	0	0.6	1
11	0	0.5	0.4	1	1
12	0.5	1	0	0.8	1
13	0.5	1	0.2	1	1
14	0.5	1	0	0.6	1
15	0.5	1	0.4	1	1

Table 14-11: Input Parameters Used to Calculate the Underground Cut-off Grade

Input Parameter	Unit	Value
Gold price	US\$/oz	1,800
Exchange rate	US\$/C\$	1.25
Gold price	C\$/oz	2,250
Royalty	%	0.00
Refining Cost	\$/oz	4.56
Metallurgical recovery (LOM average)	%	95
Long hole stoping mining method minimum stope angle	degree	43
Global mining costs	\$/t	200.16
Processing costs	\$/t	24.65
General and administration (G&A) costs	\$/t	41.11
Sustaining capital costs	\$/t	80.22
Total costs	\$/t	346.15
Mineral Resource cut-off grade	g/t Au	5.7

14.1.12 Reconciliation

Historically, since the beginning of the underground operation at Westwood, the mine-to-mill reconciliation shows a regular negative 27% discrepancy on ounces of gold (overall 73%) between the estimated Mineral Resource and the mill, meaning the mill is steadily returning 27% more ounces than planned.

It has been demonstrated that this discrepancy was caused by a sampling bias in the drill hole database.

To mitigate this discrepancy, the geological interpretation was tightened to mineralized intervals only instead of a minimum mining width strategy, and MIK interpolation was preferred where reconciliation data were available.

A total of 149 reconciled stopes, where stope survey data were available, were selected for evaluation within the 2024 block model to assess the quality of the new interpolation. A total of 113 of these stopes were located in lenses interpolated by MIK, while 36 stopes were located in other lenses interpolated by OK. The results for the different comparisons are presented in Table 14-12.

Table 14-12: Comparison between Block Models and Mill by Interpolation Method

Interpolation Method	Tonnage (%)	Grade (%)	Ounces (%)
Historical (2010 to 2021)	50	145	73
MIK/OK overall (combined OK and MIK lenses)	101	86	87

Despite the tonnage discrepancy due to the inconsistencies between the volume surveyed and the block model, the overall MIK/OK model shows a better reconciliation to gold grade and ounces than do the historical results. OK is affected by the same sampling bias as the historical results. As MIK has been modified to correct the sampling bias, the correlation between the block model and mill is within acceptable industry performance parameters for a gold deposit.

The overall performance of the hybrid model with MIK and OK interpolation was underestimated to better align with the OK model (87%) when compared to the reconciliation data. This suggests the necessity of using the MIK method to mitigate the deviation of the estimation from actual mill production. MIK estimation can achieve better alignment with the reconciliation by adjusting the weights of higher grades in the upper tail of the distributions. However, the QP employed a conservative strategy for this estimate to limit any compensation of the metal by the MIK and avoid artificially high grades.

14.2 Grand Duc

14.2.1 Introduction

Mineral Resource estimation is based on 650 core holes (104,799 m drilled) and 64,491 assays. The database supporting estimation was closed as at 15 November, 2023. Mineral resource estimation was completed using Leapfrog Edge version 2023.2.3.

Whole block cells have dimensions of 5 m long (X-axis) x 5 m wide (Y-axis) x 10 m vertical (Z-axis). The block model was rotated along the azimuth to coincide with the primary mineralized trend orientation. No sub-cells were applied to the model.

14.2.2 Models and Domains

Three models were constructed, an economic model, a lithological model, and a structural model (Table 14-13 and Figure 14-8).

Table 14-13: Models and Domains, Grand Duc

Zone	Description	Sub-model	Description
Zone 1	Low-grade shell generated using 10 m composites with a grade range from 0.3–0.8 g/t Au.	HG1 in Zone1.	High-grade shell generated using 10 m composites with a grade ≥ 0.8 g/t Au.
		HG2 in Zone1.	High-grade shell generated using 10 m composites with a grade ≥ 0.8 g/t Au.
		HG3 in Zone1.	High-grade shell generated using 10 m composites with a grade ≥ 0.8 g/t Au.
		North–south veins.	High-grade veins generated using 2 m composites with a grade ≥ 0.8 g/t Au along a north–south structural trend.
Zone 2 (CT Zone)	Low-grade shell generated using 10 m composites with a grade >0.3 g/t Au.		
Zone 3	Low-grade shell generated using 10 m composites with a grade >0.3 g/t Au.		
Zone 5	Low-grade shell generated using 10 m composites with a grade >0.3 g/t Au.		
Unconstrained	Dilution volume comprising everything remaining outside of all other domains.		

Figure 14-8: Model and Zone Location Map, Grand Duc

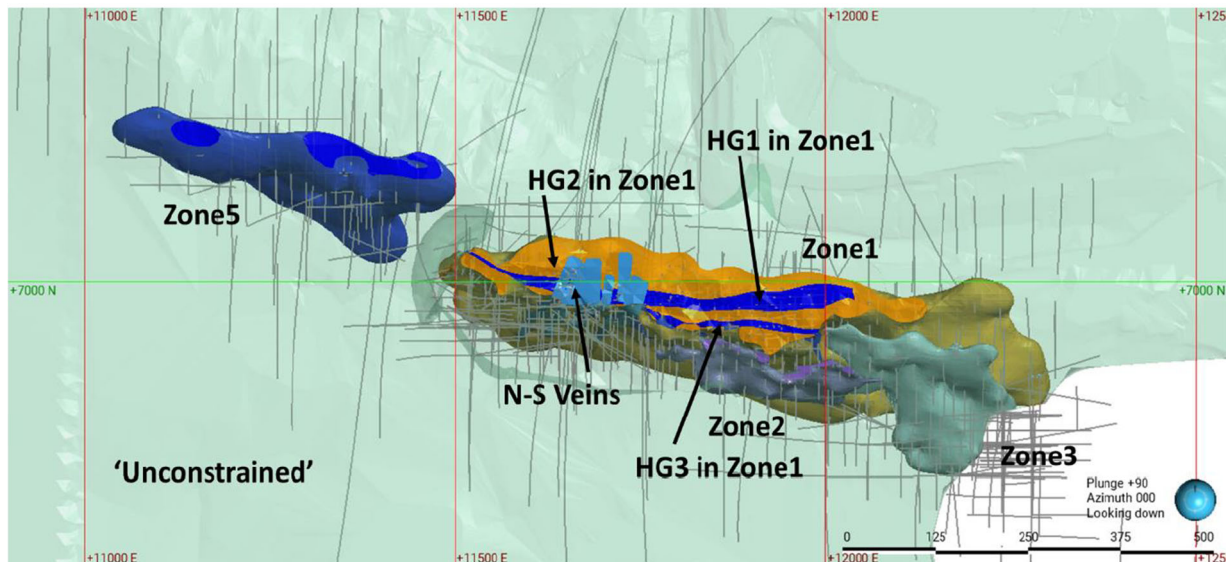

Note: Figure prepared by IAMGOLD, 2024.

The economic model was used for interpolation, and consists of north–south-trending high-grade veins, low-grade envelopes, high-grade zones, and a dilution solid.

A minimum thickness of 1 m was used to model the north–south veins, and a buffer of 5 m was applied to the wireframes for grade interpolation purposes.

14.2.3 Capping

Separate grade capping studies were completed for each estimation domain. Caps were applied to raw assay values prior to compositing. Caps as shown in Table 14-14 were selected on the basis of examination of histogram and log probability plots.

A three-step capping process was used on composites during estimation to limit unreasonable estimation of very high-grade composites. The first interpolation pass used composites where the highest capping value was applied, and subsequent passes used lower capping limits on composites with limited volume influence.

Table 14-14: Grade Capping, Grand Duc

Domain	Sub-Domain	Cap Applied (g/t Au)	Number of Samples Capped
Zone 1	HG1	15	22
	HG2	10	3
	HG3	20	7
	LG	10	57
Zone 2		40	3
Zone 3		12	15
Zone 5		16	4
North-south zones		50	22
Unconstrained		20	36

14.2.4 Compositing

All drill hole intervals were composited to 1.5 m intervals inside the mineralized zones. If the residual assay was <1.5 m (tail), it was distributed equally between the previous composites.

14.2.5 Density

Fixed density values were applied in the block model using a Leapfrog script. The median density values were based on the lithological model:

- Overburden: 2 t/m³;
- Dyke: 2.7 t/m³;
- Trondhjemite (2GD): 2.68 t/m³;
- Trondhjemite contact (2GDCT): 2.66 t/m³;
- All other lithologies: 2.67 t/m³.

14.2.6 Variography

Three-dimensional directional variography was performed on the 1.5 m capped composites for all of the estimation domains. The ellipsoids used in estimation were based on the variogram results.

14.2.7 Grade Interpolation

Ordinary kriging was used for estimating the grade in each domain. Validation models using inverse distance weighting to the third power (ID3) and nearest-neighbour methods were completed.

A combination of hard and soft boundaries was used for the resource estimate, tuned to the domain. Soft boundaries were used between the north–south veins and the high-grade zones, and hard boundaries were used between the low-grade envelopes.

Search ellipsoids were oriented dynamically so that the strike and dip followed the undulations of the mineralized domains for the north–south veins, the high-grade zones, Zone 1, and Zone 2. For the remaining low-grade envelopes, such as Zone 3 and Zone 5, a fixed orientation was applied for the search ellipsoids.

The grade interpolation was a three-pass process, increasing search ranges between passes, and varying the minimum number of composites:

- The first pass used a relatively small radius search ellipsoid to interpolate the mineralization blocks located in the close vicinity of the drill holes;
- The second pass interpolated the blocks that were not interpolated during the previous pass;
- The third pass was defined to populate the remaining blocks within the mineralization solids.

An outlier restriction strategy was also used (see Section 14.2.3).

Estimation parameters are provided in Table 14-15.

14.2.8 Confidence Classification

No Measured Mineral Resources were classified other than the material in stockpiles.

Indicated Mineral Resource classification required at least three drill holes within a 30 m radius.

Inferred Mineral Resource classification required at least three drill holes within a 50 m radius.

Table 14-15: Estimation Parameters

	General	Ellipsoid Ranges			Ellipsoid Directions			Variable Orientation	Number of Samples		Outlier Restrictions			Drillhole Limit	
		Interpolant Name	Max	Inter	Min	Dip	Dip Azi.		Pitch	Min	Max	Method	Distance	Threshold	Max Samples per Hole
31	Kr, HG 2_Zone 1 Pass 1	25	40	12				HG_zones	9	15	Clamp	10	12.5	4	VRAI
32	Kr, HG 2_Zone 1 Pass 2	37.5	60	18				HG_zones	9	20	Clamp	50	5	4	VRAI
33	Kr, HG 2_Zone 1 Pass 3	50	80	24				HG_zones	5	20	Clamp	15	3	4	VRAI
34	Kr, HG 3_Zone 1 Pass 1	50	25	5				HG_zones	9	15	Clamp	25	3	4	VRAI
35	Kr, HG 3_Zone 1 Pass 2	75	37.5	7.5				HG_zones	9	20	Discard	10	3	4	VRAI
36	Kr, HG 3_Zone 1 Pass 3	100	50	10				HG_zones	7	20	Discard	5	3	4	VRAI
37	Kr, HG Zone 1 Pass 1	20	16	8				HG_zones	5	8	Clamp	25	5	2	VRAI
38	Kr, HG Zone 1 Pass 2	30	24	12				HG_zones	5	8	Clamp	25	3	2	VRAI
39	Kr, HG Zone 1 Pass 3	40	32	16				HG_zones	7	20	Discard	10	3	4	VRAI
40	Kr, LG Zone 1 Pass 1	30	25	5				HG_zones	5	8	Discard	50	8	2	VRAI
41	Kr, LG Zone 1 Pass 2	45	37.5	7.5				HG_zones	9	20	Discard	20	5	4	VRAI
42	Kr, LG Zone 1 Pass 3	60	50	10				HG_zones	5	20	Discard	15	3	4	VRAI
43	Kr, LG Zone 2 Pass 1	55	40	15				VO, 01_Au_LG_Zone_2	9	15	None			4	VRAI
44	Kr, LG Zone 2 Pass 2	75	40	20				VO, 01_Au_LG_Zone_2	9	20	Clamp	10	2	4	VRAI
45	Kr, LG Zone 2 Pass 3	110	80	30				VO, 01_Au_LG_Zone_2	5	20	Clamp	5	2	4	VRAI
46	Kr, LG Zone 5 Pass 1	80	25	7	65.5	175.4677	160.89	None	7	15	None			3	VRAI
47	Kr, LG Zone 5 Pass 2	120	37.5	10	65.5	175.4677	160.89	None	7	20	Clamp	35	3	3	VRAI
48	Kr, LG Zone 5 Pass 3	160	50	15	65.5	175.4677	160.89	None	7	20	Clamp	15	3	3	VRAI
49	Kr, Unconstrained Pass 1	15	15	5				HG_zones	7	15	None			3	VRAI
50	Kr, Unconstrained Pass 2	40	40	15				HG_zones	4	12	Clamp	50	10	3	VRAI
51	Kr, Veines N S Pass 1	48.5	48.67	7.5				Veines_NS	7	12	None			3	VRAI
52	Kr, Veines N S Pass 2	75	75	10				Veines_NS	4	12	Clamp	50	20	2	VRAI
53	Kr, Veines N S Pass 3	100	100	15				Veines_NS	4	12	Discard	20	5	2	VRAI
54	Kr, Zone 3 Pass 1	50	50	5	38.9	173.2744	160.53	None	7	15	Clamp	10	4	3	VRAI
55	Kr, Zone 3 Pass 2	75	75	7.5	38.9	173.2744	160.53	None	7	20	Clamp	35	3	3	VRAI
56	Kr, Zone 3 Pass 3	100	100	10	38.9	173.2744	160.53	None	7	20	Clamp	15	3	3	VRAI

Categories were manually smoothed to remove instances of isolated blocks of one confidence category that were surrounded by blocks of a different category.

A cross-section showing the final classifications is provided in Figure 14-9.

14.2.9 Block Model Validation

Model validation included:

- Swath plots comparing the block model grades to the raw assay data;
- Comparisons with previous mineral resource estimates;
- Examination of detailed reconciliation results by domain;

Results indicated that the model used in estimation was acceptable.

14.2.10 Reasonable Prospects of Eventual Economic Extraction

14.2.10.1 Constraining Pit Shell

Conceptual mining parameters used for the Grand Duc deposit are presented in Table 14-16. A gold price of US\$1,800/oz was used in the conceptual pit shell that was used to constrain the Mineral Resource estimate.

14.2.10.2 Stockpiles

The stockpile tonnage estimate is based on Wenco truck counts that are reconciled on a monthly basis with drone surveys of the stockpiles. Grade is assigned to the stockpiles from the grades of the material mined from the short-term grade model. There are a number of stockpiles, which have varying grade cut-offs, ranging from 0.54–0.9 g/t Au.

14.2.10.3 Cut-off Grades

Cut-off grades were calculated using a US\$1,800 gold price and budget site costs for 2024–2028.

The CIL cut-off grade for fresh rock was calculated at 0.54 g/t Au.

14.3 Mineral Resource Statement

Mineral Resources are reported with an effective date of 30 September, 2024 using the Mineral Resource definitions set out in the 2014 CIM Definition Standards, and are reported in situ, inclusive of those Mineral Resources converted to Mineral Reserves. Mineral Resources that are not Mineral Reserves do not have demonstrated economic viability.

14.3.1 Westwood

Measured, Indicated, and Inferred Mineral Resources estimated for the Westwood deposit are provided in Table 14-17. A section showing the confidence classifications within the mine is included as Figure 14-10.

The Qualified Person for the estimate other than in stockpiles is Mr. Martin Perron, P.Eng., of Norda Stelo. The Qualified Person for the stockpile estimate is Mr. Louis Nkoy Manda Mbomba, P.Eng., an IAMGOLD employee.

14.3.2 Grand Duc

Measured, Indicated, and Inferred Mineral Resources estimated for the Grand Duc deposit, are provided in Table 14-18. A section showing the confidence classifications within the open pit is included as

The Qualified Person for the estimate is Mr. Abderrazak Ladidi, P.Geo. an IAMGOLD employee.

14.3.3 Westwood and Grand Duc

The combined Measured, Indicated and Inferred Mineral Resources estimated for Westwood and Grand Duc are included in Table 14-19.

This table is not additive to Table 14-17 and Table 14-18.

Table 14-17: Mineral Resource Statement, Westwood

Class	Tonnes	Gold Grade (g/t Au)	Contained Ounces
Measured	777,000	13.09	327,000
Measured (Stockpiles)	4,000	8.64	1,200
Indicated	3,190,000	12.74	1,306,700
Measured + Indicated	3,971,000	12.80	1,634,900
Inferred	4,289,000	13.03	1,797,400

Notes to accompany Westwood Mineral Resource Table

1. The effective date of the Mineral Resource estimate is 30 September, 2024.
2. The Qualified Person for the estimate excepting stockpiles is Martin Perron, P.Eng., from Norda Stelo Inc. The Qualified Person for the stockpile estimate is Mr. Louis Nkoy Manda Mbomba, P.Eng., an IAMGOLD employee.
3. Mineral Resources are reported inclusive of Mineral Reserves. Mineral Resources that are not converted to Mineral Reserves do not have demonstrated economic viability.
4. The estimate encompasses 128 mineralized lenses in three zones (Corridor North, Westwood, and Zone 2 Extension) using the grade of the adjacent material when assayed or a value of zero when not assayed. Three dilution buffer zones encompassing all mineralized zones (one for each zone) were created to better reflect the internal dilution within the constraining shapes.
5. High-grade capping supported by statistical analysis was done on raw assay data before compositing. It was established on a zone-by-zone basis, varying from 75–500 g/t Au for mineralized zones and 10–20 g/t Au for the dilution buffer zones. Composites (1.0 m) were calculated within the zones using the grade of the adjacent material when assayed or a value of zero when not assayed.
6. The estimate was completed using a sub-block model in Isatis.neo 2024.04. The parent block size was 4 x 1 x 4 m (subblocks of 1 x 0.5 x 1 m).
7. Grade interpolation was obtained by multiple-indicator kriging for 13 lenses and ordinary kriging for all remaining lenses and buffers using hard boundaries.
8. Density values were assigned by lens group. Densities of 2.9, 3.7, 3.1, 3.0, 3.0 and 3.1 g/cm³ were assigned to groups A, B, C, E, F and G, respectively. A value of 2.8 g/cm³ was assigned to the Corridor North buffer, 2.9 g/cm³ to the Westwood buffer and 2.9 g/cm³ to the Zone 2 Extension buffer.
9. The mineral resource estimate is classified as Measured, Indicated, and Inferred. The Inferred Mineral Resource category is defined with a minimum of two drill holes in areas where the drill spacing is <75 m, and reasonable geological and grade continuity have been demonstrated. The Indicated Mineral Resource category is defined with a minimum of two drill holes in areas where the drill spacing is <15 m, and reasonable geological and grade continuity have been demonstrated. Measured Mineral Resources were classified when Indicated Mineral Resources are present

within 10 m of an underground opening within a mineralized zone. The initial resource classification was edited with a mix of automated and manual methods to eliminate isolated blocks of one confidence category, considering the spatial continuity of drill holes, and was run in each mineralized solid to upgrade inferred blocks, or downgrade indicated blocks locally, as needed. The measured resources from the original classification were checked and confirmed with the mining development data. The Measured Mineral Resources from the original classification were not smoothed to prevent downgrading the classification.

10. The Mineral Resource estimate is locally constrained within Deswik Stope Optimizer shapes using a minimal mining width of 2.4 m for long hole stoping. It is reported at a cut-off grade of 5.7 g/t Au. The following parameters were used: mining cost = \$200.16/t; processing cost = \$24.65/t; G&A = \$41.11/t; sustaining capital cost = \$80.22/t; refining costs = \$4.56/oz; gold price = US\$1,800.00/oz; US\$/C\$ exchange rate = 1.25; and process recovery = 95.0%. The cut-off grades should be re-evaluated in light of future prevailing market conditions (metal prices, exchange rates, mining costs etc.).
11. The number of metric tonnes was rounded to the nearest thousand, as required by Form 43-101F1, and any discrepancies in the totals are due to rounding effects. The metal contents are presented in troy ounces (tonnes x grade / 31.10348) rounded to the nearest hundred. Numbers may not add up due to rounding.
12. The Qualified Person is not aware of any known environmental, permitting, legal, political, title-related, taxation, socio-political, or marketing issues that could materially affect the Mineral Resource estimate.

Figure 14-10: Westwood Mineral Resources Classification

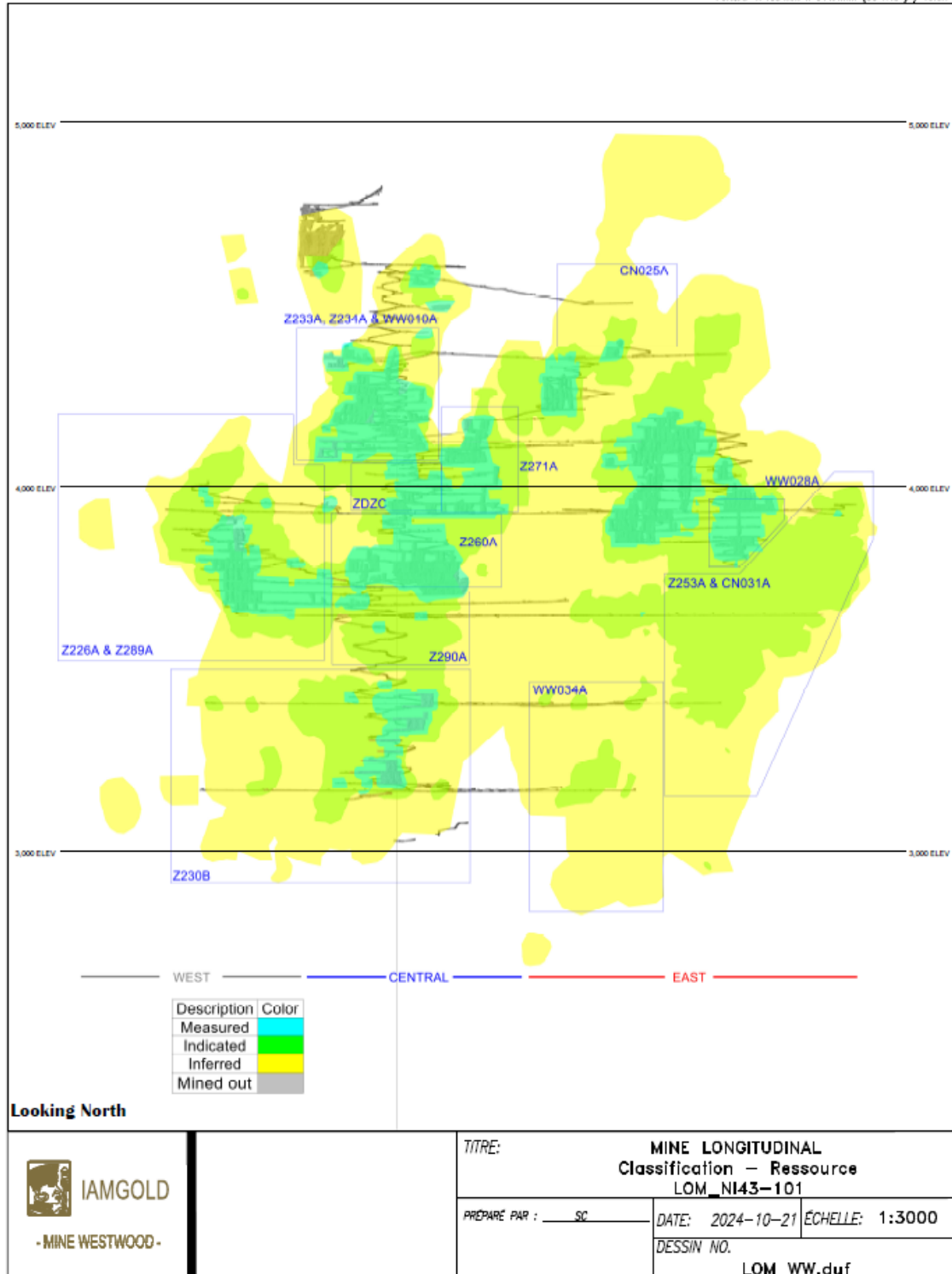

Table 14-18: Mineral Resource Statement, Grand Duc

Class	Tonnes	Gold Grade (g/t Au)	Contained Ounces
Measured (Stockpiles)	268,000	0.64	5,500
Indicated	2,740,000	1.31	115,600
<i>Measured + Indicated</i>	<i>3,008,000</i>	<i>1.25</i>	<i>121,000</i>
Inferred	80,000	1.28	3,300

Notes to accompany Grand Duc Mineral Resource Table

1. Mineral Resources are reported at an effective date of 30 September, 2024. The Qualified Person for the estimate is Mr. Abderrazak Ladidi, P.Geol. an IAMGOLD employee.
2. Measured Mineral Resources are reported in place as stockpiles. Indicated and Inferred Mineral Resources are insitu.
3. Mineral Resources are reported inclusive of Mineral Reserves. Mineral Resources that are not converted to Mineral Reserves do not have demonstrated economic viability
4. Mineral Resources are reported using the 2014 CIM Definition Standards.
5. Mineral Resources are reported assuming a gold price of US\$1,800 and a US\$:C\$ exchange rate of 1.25. Mineral Resources are constrained within an optimized open pit shell, which use input assumptions including: mining costs of \$12.71/t mineralization and variable waste costs ranging from \$4.07–\$5.71, process costs of \$19.29/t and metallurgical recoveries that average 92%. Mineral Resources that are not in stockpiles are reported at a cut-off of 0.54 g/t Au. Mineral Resources in stockpiles have variable cut-offs, depending on the stockpile, which range from 0.54–0.9 g/t Au.
6. The number of metric tonnes was rounded to the nearest thousand and any discrepancies in the totals are due to rounding effects. The metal contents are presented in troy ounces (tonnes x grade / 31.10348) rounded to the nearest hundred. Numbers may not add up due to rounding.

Table 14-19: Mineral Resource Statement, Westwood and Grand Duc

Class	Tonnes	Gold Grade (g/t Au)	Contained Ounces
Measured (Stockpiles)	272,000	0.76	6,700
Measured	777,000	13.09	327,000
Indicated	5,930,000	7.46	1,422,300
Measured + Indicated	6,979,000	7.83	1,756,000
Inferred	4,369,000	12.82	1,800,700

Notes to accompany Westwood and Grand Duc Mineral Resource Table

1. Mineral Resources are reported at an effective date of 30 September, 2024.
2. The Qualified Person for the Westwood estimate excepting stockpiles is Martin Perron, P.Eng., from Norda Stelo Inc. The Qualified Person for the stockpile estimate is Mr. Louis Nkoy Manda Mbomba, P.Eng., an IAMGOLD employee. The Qualified Person for the Grand Duc estimate is Mr. Abderrazak Ladidi, P.Ge. an IAMGOLD employee.
3. Other than Stockpiles, Measured and Indicated and Inferred Mineral Resources are insitu.
4. Mineral Resources are reported inclusive of Mineral Reserves. Mineral Resources that are not converted to Mineral Reserves do not have demonstrated economic viability
5. Mineral Resources are reported using the 2014 CIM Definition Standards.
6. Footnotes detailing the key parameters and assumptions for the Mineral Resource estimate for Westwood accompanying Table 14-17 and footnotes detailing the key parameters and assumptions for the Mineral Resource estimate for Grand Due accompanying Table 14-18 are also applicable to this table.
7. The number of metric tonnes was rounded to the nearest thousand and any discrepancies in the totals are due to rounding effects. The metal contents are presented in troy ounces (tonnes x grade / 31.10348) rounded to the nearest hundred. Numbers may not add up due to rounding.
8. This table is not additive to Table 14-17 and Table 14-18.

14.4 Factors that May Affect the Mineral Resource Estimates

Areas of uncertainty that may materially impact the Mineral Resource estimates include:

- Changes to long-term gold price assumptions;
- Changes in local interpretations of mineralisation geometry and continuity of mineralised zones;
- Changes to geological shape and continuity assumptions;
- Changes to metallurgical recovery assumptions;
- Changes to the operating cut-off assumptions for assumed long hole mining operations at Westwood;

- Changes to the inputs to the constraining pit shell used for Grand Duc;
- Changes to the input assumptions used to derive the conceptual underground outlines used to constrain the Westwood estimate;
- Changes to the cut-off grade used to report the Grand Duc estimate;
- Changes to the cut-off grades used to constrain the Westwood estimate;
- Variations in geotechnical, hydrogeological, and mining assumptions;
- Changes to environmental, permitting, and social license assumptions;
- Changes to legal, political, title-related, taxation, socio-political, or marketing assumptions.

14.5 QP Comment on Item 14 “Mineral Resource Estimates”

The QPs are of the opinion that Mineral Resources were estimated using industry-accepted practices, and conform to the 2014 CIM Definition Standards.

The decrease in Measured and Indicated Mineral Resources estimated for the Westwood Mine from the last technical report is primarily due to tighter confidence criteria applied to the mine planning process. To reduce variations in mine planning, Indicated Mineral Resources were classified based on the completed definition drill pattern requirements. The changes to the Indicated Mineral Resources classification requirements were partly responsible for the increase in Inferred Mineral Resources; the other key factor contributing to increases in Inferred Mineral Resources was identification of additional mineralization through exploration drilling.

There are no other environmental, legal, title, taxation, socioeconomic, marketing, political or other relevant factors known to the QPs that would materially affect the estimation of Mineral Resources that are not discussed in this Report.

15 MINERAL RESERVE ESTIMATES

15.1 Introduction

Proven and Probable Mineral Reserves are reported for the Westwood and Grand Duc deposits and have been converted from Indicated and Measured Mineral Resources, respectively.

Mine designs supporting the Mineral Reserves were based on the operating life-of-mine plans assuming underground (Westwood) and open pit (Grand Duc) mining methods.

Inferred Mineral Resources within the mine designs (DSO) were treated as internal dilution with a grade assigned as 0.5 g/t Au, and the LOM plan is only based on Measured and Indicated Mineral Resources.

15.2 Westwood

15.2.1 Development Of Mining Case

There is significant history and data available on the geological setting, mining methods, mining conditions, mining recoveries and dilution, production capacity and mining costs. These historical data are used extensively in the Mineral Reserve estimation process.

The throughput rate assumption of 960 t/d is based on a detailed LOM plan that includes consideration of current and planned mining methods, geotechnical constraints and risks, materials handling system, mining equipment fleet, labour, infrastructure such as power supply, dewatering, backfilling, and ventilation.

The mine plan assumes long-hole open stoping methods with paste fill. Stopes are on average 17 m long and 25 m high, but can vary depending on geology (block dimensions), geometry (dip of the ore), logistical and geotechnical considerations, and historical data.

Mine plans are adjusted by mine planners to minimize the risk of ground failures and seismicity through the establishment of an optimal mining block size and shape, and mine sequencing.

Mine sequencing is established through close collaboration between the mine planners and the geotechnical teams. Each zone undergoes a zone design analysis, and each stope is subject to stope design as well as geotechnical and planning considerations. The intent of this analysis is to improve the mine plan while simultaneously reducing geotechnical and operational risks.

Each mining block converted from Mineral Resources to Mineral Reserves was evaluated using an economic analysis. Key parameters used in the economic analysis include:

- Infrastructure required to access the mining block (drift, ramp, escape way);
- Appropriate mining method/parameters (e.g., dilution, mining recovery, mill recovery);
- Appropriate gold price and cost factors;
- Geotechnical considerations based on previous experience and current data available.

Economic analyses are performed on a full-cost basis, including consideration of administration/support, depreciation, and capital expense costs.

15.2.2 Cut-off Grades

The operations use a break-even cut-off grade for Mineral Reserve reporting, based on the formula:

- Break-even cut-off grade = costs/revenue = (mining cost + processing cost + general & administrative cost + sustaining cost)/(metal price – transport and refining cost – royalties) x process recovery.

The input assumptions are summarized in Table 15-1. The break-even cut-off grade is 7.58 g/t Au, reducing to 6.82 g/t Au when the mine call factor is applied (see Section 15.2.3).

Reconciliation has shown that the average grade reported to the mill is higher than the stope grade estimate. A mine call factor is added to the cut-off grade to adjust the grade in the stopes to better align with the mill grade. This results in a reduction of 10% (approximately 1.03 g/t Au) in the cut-off grade for the Mineral Reserve estimates.

15.2.3 Dilution and Mining Recovery

The historic external mining dilution is estimated at 63% for Mineral Reserves, with an associated grade of 0.5 g/t Au.

This factor is applied to the stope shapes only.

Table 15-1: Westwood Input Parameters, Break-even Cut-off Grade

Parameter	Unit	Value
Gold price	US\$/oz	1,500
Exchange rate	US\$/C\$	1.25
Gold price	C\$/oz	1,875
Refining Cost	\$/oz	4.56
Metallurgical recovery (LOM average)	%	95
Mine call factor	%	10
Global mining costs	\$/t	200.16
Processing costs	\$/t	24.65
General and administration (G&A) costs	\$/t	41.11
Sustaining capital costs	\$/t	80.22
Total costs	\$/t	346.15
Mineral Reserve cut-off grade	g/t Au	6.82

15.3 Grand Duc

15.3.1 Pit Optimization

Open pit mining operations commenced in 2019 at Grand Duc, providing historical data on the geological setting, mining method, mining conditions, mining recoveries and dilution, production capacity, and mining costs. These historical data are used in the Mineral Reserve estimation process.

Inputs to the pit optimization runs are summarized in Table 15-2. The basis of the mine designs are discussed in Section 16.3.4.

Mine designs include the geotechnical parameters that are discussed in Section 16.3.1.

Input data are based on historical costs and current open pit mining contractor costs. Costs include allowances for general and administrative (G&A), primary crusher, processing, and environmental costs.

Table 15-2: Optimization Parameters, Grand Duc

Item	Unit	Value
Bench height	m	10–20
Strip ratio		2.15
Bench face angles	°	70(north)-75(south)
Mining dilution	%	10
Throughput rate	t/d	1,958
Metallurgical recovery (LOM average)	%	92
Gold price	US\$/oz	1,800
Exchange rate	US\$/C\$	1.25
Mining cost (ore)	\$/t mined	12.71
Mining cost (waste)	\$/t mined	4.07 in overburden, 5.71 in rock.
Processing and environment cost	\$/t processed	19.29
Mill capital costs and project	\$ M/a	1.02
General and administrative	\$ M/a	0.8
Breakeven mill feed cut-off grade	g/t Au	0.54

15.3.2 Cut-off Grades

The operations use a break-even cut-off grade for Mineral Reserve reporting, based on the formula:

- Break-even cut-off grade = costs/revenue = (mining cost + processing cost + general & administrative cost + sustaining cost)/(metal price – transport and refining cost – royalties) x process recovery.

The input assumptions are summarized in Table 15-2. The break-even cut-off grade is 0.54 g/t Au; however, production uses different cut-off grades to segregate material and prioritize materials to haul to the mill.

15.3.3 Dilution and Mining Recovery

The Mineral Reserve estimate includes dilution due to contamination of ore material during shoveling at the boundaries. The rock type does not impact dilution due to its homogeneity in the pit. A second dilution type considered is back break, which is consistent around the pit, and is included in the pit design.

The dilution assumption is 10% in the pit design and Mineral Reserve estimate, based on historical data. No mining recovery is applied.

15.4 Mineral Reserves Statement

Mineral Reserves are reported with an effective date of 30 September 2024 using the Mineral Reserve definitions set out in the 2014 CIM Definition Standards, and are reported at the point of delivery to the process plant. The Qualified Person for the estimates is Louis Nkoy Manda Mbomba, P.Eng., an IAMGOLD employee.

Mineral Reserves estimated for Westwood are provided in Table 15-3. The location of the Mineral Reserve estimates for Westwood is shown in Figure 15-1. Mineral Reserves estimated for Grand Duc are provided in Table 15-4. A combined Mineral Reserve table for Westwood and Grand Dus is included as Table 15-5. This table is not additive to Table 15-3 and Table 15-4.

15.5 Factors that May Affect the Mineral Reserve Estimate

Factors that may affect the Mineral Reserve estimate include:

- The gold price influences Mineral Reserves, and its increase or decrease significantly impacts the cut-off grade and forecast cashflow outcomes;
- Geotechnical constraints must be rigorously respected in mining sequences. At the same time, the implementation of the Westwood algorithm allows all zones to be opened, which increases Mineral Reserves;
- Seismicity always represents a risk, but geotechnical strategies and tactics reduce this risk and allow for safe mining;
- Mining recovery and dilution are factors that directly influence the Mineral Reserves estimates. Even small changes in dilution can affect mining recoveries, and hence the ounces in the material delivered to the process plant;
- The mining cost factor influences the cut-off grade and the Mineral Reserve estimates;
- Process recovery is an element that impacts Mineral Reserves estimate, and maintaining LOM process recoveries at around 95% will represent a challenge. This challenge is being mitigated by the proposed capital investment plan.

Table 15-3: Mineral Reserves Statement, Westwood

Confidence Category	Tonnage	Gold Grade (g/t Au)	Contained Ounces
Proven	721,000	12.60	292,000
Probable	1,870,000	11.02	662,200
Stockpiles (Proven)	4,000	8.64	1,200
Total Proven + Probable	2,595,000	11.45	955,400

Notes to Accompany Westwood Mineral Reserves Table:

1. Mineral Reserves are reported at the point of delivery to the process plant with an effective date of 30 September, 2024. The Qualified Person for the estimate is Louis Nkoy Manda Mbomba, P.Eng., an IAMGOLD employee.
2. Mineral Reserves are reported using the 2014 CIM Definition Standards.
3. Mineral Reserves are reported using a gold price of US\$1,500/oz Au and assume a C\$:US\$ exchange rate of 1.25. Mineral Reserves are constrained within mineable shapes, that use input assumptions including long-hole open stope mining methods, mining costs of \$200.16/t, process costs of \$24.65/t, general and administrative costs of \$41.11/t, Sustaining capital cost of \$80.22/t, gold treatment and refining costs of \$4.56/t, minimum mining width of 2.4 m, dilution assumption of 63% at 0.5 g/t Au, mining recovery of 85%, and metallurgical recoveries averaging 95%. Mineral Reserves are reported at a 6.82 g/t Au cut-off, which is inclusive of a 10% mine call factor.
4. Table numbers have been rounded. Totals may not sum due to rounding.
5. This table is not additive to Table 15-3 and Table 15-4.

Figure 15-1: Westwood Mineral Reserve Classification, Including Indicated Mineral Resources Not Converted to Mineral Reserves

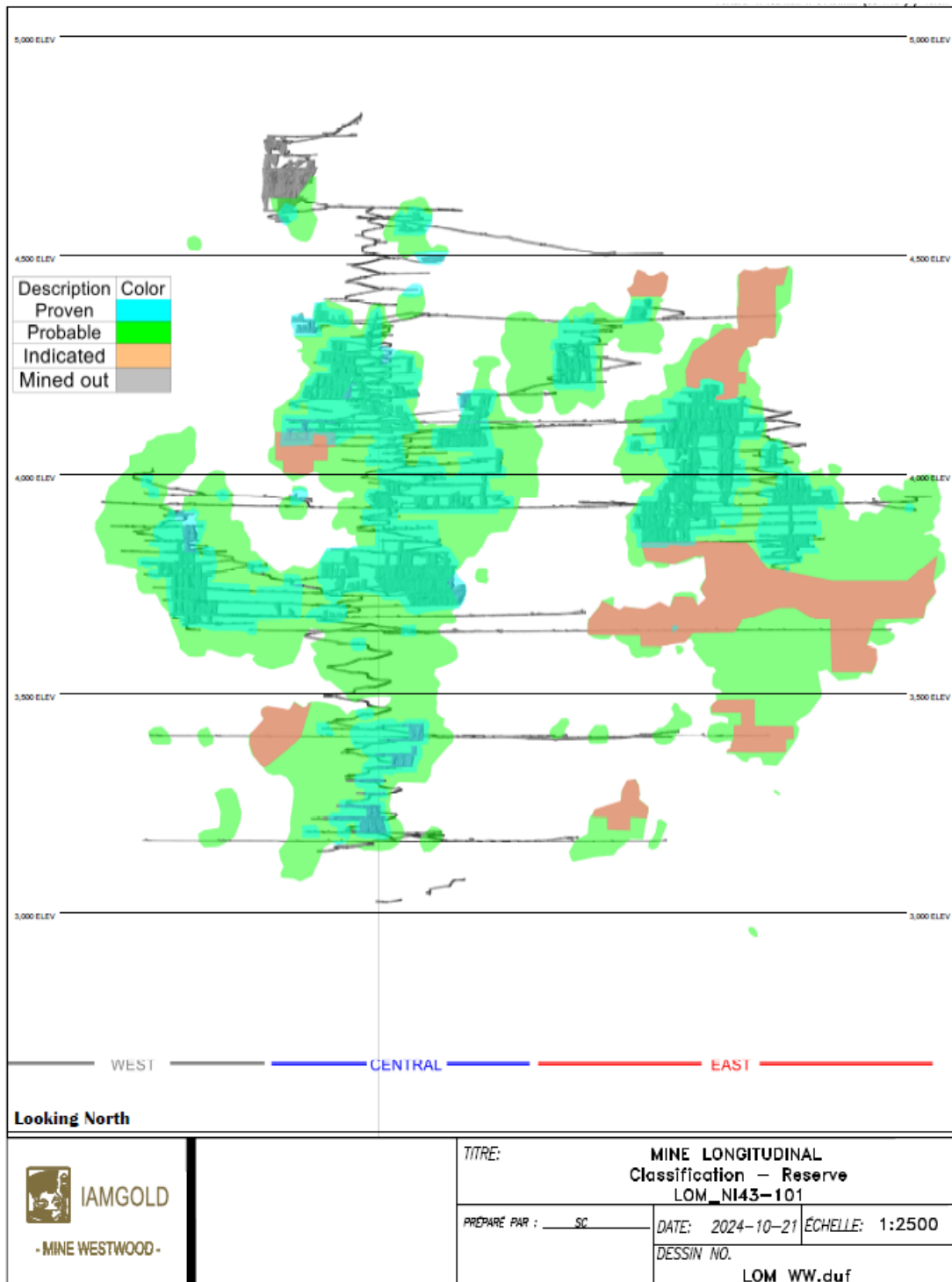

Table 15-4: Mineral Reserves Statement, Grand Duc

Confidence Category	Tonnage	Gold Grade (g/t Au)	Contained Ounces
Proven	—	—	—
Probable	1,445,000	1.09	50,900
Stockpiles (Proven)	268,000	0.64	5,500
Total Proven + Probable	1,713,000	1.02	56,300

Notes to Accompany Grand Duc Mineral Reserves Table:

1. Mineral Reserves are reported at the point of delivery to the process plant with an effective date of 30 September, 2024. The Qualified Person for the estimate is Louis Nkoy Manda Mbomba, P.Eng., an IAMGOLD employee.
2. Mineral Reserves are reported using the 2014 CIM Definition Standards.
3. Mineral Reserves are reported using a gold price of US\$1,800/oz Au and assume a US\$:C\$ exchange rate of 1.25. Mineral Reserves are constrained within an optimized open pit shell, which use input assumptions including: mining costs of \$12.71/t ore and variable waste costs ranging from \$4.07–5.71, process costs of \$19.29/t, 10% dilution, bench face angles that range from 70° (north)–75°(south), and metallurgical recoveries that average 92%. Mineral Reserves are reported at a 0.54 g/t Au cut-off.
4. Table numbers have been rounded. Totals may not sum due to rounding.

Table 15-5: Mineral Reserves Statement, Westwood and Grand Duc

Confidence Category	Tonnage	Gold Grade (g/t Au)	Contained Ounces
Proven	721,000	12.60	292,000
Probable	3,315,000	6.69	713,000
Stockpiles (Proven)	272,000	0.76	6,700
Total Proven + Probable	4,308,000	7.30	1,011,700

Notes to Accompany Westwood and Grand Duc Mineral Reserves Table:

1. Mineral Reserves are reported at the point of delivery to the process plant with an effective date of 30 September, 2024. The Qualified Person for the estimate is Louis Nkoy Manda Mbomba, P.Eng., an IAMGOLD employee.
2. Mineral Reserves are reported using the 2014 CIM Definition Standards.
3. Footnotes detailing the key parameters and assumptions for the Mineral Reserve estimate for Westwood accompanying Table 15-3 and footnotes detailing the key parameters and assumptions for the Mineral Reserve estimate for Grand Duc accompanying Table 15-4 are also applicable to this table.
4. Table numbers have been rounded. Totals may not sum due to rounding.
5. This table is not additive to Table 15-3 and Table 15-4.

15.6 QP Comment on Item 15 “Mineral Reserve Estimates”

The QP is of the opinion that Mineral Reserves were estimated using industry-accepted practices, and conform to the 2014 CIM Definition Standards.

The mine design has undergone significant changes to adhere to geotechnical recommendations regarding mining sequences while maintaining the long-hole open stoping method. This sequence is based on a geotechnical algorithm implemented due to a better understanding of the mine's structures and rock mechanics. These changes significantly reduce seismicity and increase mining safety. The mining sequence is tailored to accommodate the geotechnical conditions encountered during operations.

There are no other environmental, legal, title, taxation, socioeconomic, marketing, political or other relevant factors known to the QP that would materially affect the estimation of Mineral Reserves that are not discussed in this Report.

The QP is not aware of any additional mining, metallurgical, infrastructure, permitting, or other factors not presented in this report that could materially affect the Mineral Reserve estimate.

16 MINING METHODS

16.1 Introduction

The mining operations at Westwood are carried out using conventional underground methods and Owner-operated equipment.

Grand Duc uses conventional open pit methods and third-party contractor-operated equipment.

16.2 Westwood

16.2.1 Geotechnical Considerations

16.2.1.1 Introduction

Geotechnical considerations have led to the most significant changes in the Westwood mining plan since the initial scoping study. Seismicity, as well as more variability in the rock mass, and less continuity in strike of ore lenses than predicted, have all resulted in changes to the mining plan. Different consulting firms have been involved since the beginning of operations to assist in assessment of the rock mass, mine design, support requirements and risk analysis. An extensive analysis of seismic risk was performed in 2021 following the significant seismic events in October 2020. This investigation included the participation of external global experts.

The geotechnical risk management program, the ground control program, and the geotechnical strategy, updated annually, provide guidance on all aspects of ground control at the mine.

16.2.1.2 Stress State

In-situ stresses were measured in 2008 on Level 840 by R. Corthésy of Montreal's École Polytechnique. Results were lower than expected, and may have been affected by the proximity of the Bousquet Fault. After comparison with regional values and historical values measured at the Doyon mine. These measurements were further updated in 2013 (Paudel and Brummer, 2014). Table 16-1 summarizes the studies. The 2016 analyses were unable to determine the orientation of the stress tensor precisely, but the orientation of the principal stress is believed to be between 0 and 55°N. Further analyses are in progress. These values were calibrated by underground observations.

Table 16-1: In Situ Stresses for Numerical Modelling

Stress	Magnitude (MPa)	Orientation (trend/plunge) (°)
σ_1	$2.0 \times \sigma_3$	030/-15
σ_2	$1.5 \times \sigma_3$	120/00
σ_3	$0.026 \times \text{depth (m)}$	210/-75

16.2.1.3 Rock Mass Classification

A detailed characterization of the geotechnical properties of the rock mass was completed in 2017, based on rock quality assessments of drill core samples, laboratory testing and geotechnical mapping. Information has been refined and updated with information from the latest drilling campaigns and experience gained from development and test stopes.

There has been limited laboratory test work performed on the different lithologies to determine the in situ characteristics since the mine started operating. Parameters vary significantly between the different rock types (Table 16-2), from a very competent basalt unit to a poor-quality felsic volcanic unit.

Geotechnical mapping was primarily used to identify the main joint families (Table 16-3). Results of the mapping were combined with intact rock characteristics to determine the rock quality index (Q) for each unit and estimate modelling parameters (Table 16-4).

16.2.1.4 Seismic History

The Westwood Mine has experienced several significant seismic events to the Report effective date, including a series of events in the central infrastructure corridor of the 104-mining block (Table 16-5).

16.2.1.5 Impact on Mine Design

The quality of rock mass affects both development and stope design. Significant anisotropy also complicates the mine design, as certain rock type may be stable when perpendicular to the regional schistosity and unstable or prone to convergence when parallel to the schistosity. Even in the same rock type, different support patterns may be required.

Table 16-2: Intact Rock Parameters

Unit	Type	Sigci (MPa)	Mi (MPa)	Young (GPa)	Poisson	Tension (Mpa)	Joint Friction (°)	Joint Cohesion (Mpa)	Joint Tension (MPa)
U3.3.0	Intact	126	11	86	0.21	18	25	13	5
U3.3.0	Rock mass	54	4	37	0.21	5	25	5	2
U4.2.0	Intact	154	15	108	0.2	19	25	14	6
U4.2.0	Rock mass	59	2	41	0.2	6	25	6	2
U4.3.0	Intact	108	9	59	0.14	13	25	7	3
U4.3.0	Rock mass	34	4	18	0.14	6	25	2	1
U4.4.0	Intact	136	13	78	0.17	17	25	12	5
U4.4.0	Rock mass	45	3	26	0.17	5	25	4	2
U4.4.1	Intact	165	15	116	0.2	19	25	18	7
U4.4.1	Rock mass	84	9	59	0.2	8	25	9	3

Table 16-3: Joint Families

Structure Type	Families	Orientation	Space (m)	Jr	Ja	Description
Foliation	S1	096/74	0.01–1	1	2–4	Dominant structure
Joint	J2a	354/82	0.5	1	1–2	Main type of conjugate joint
	J2b	166/80				
Joint	J3	347/14	1	1.5	1.5–2	Sub-horizontal
Joint	J4a	044/78	>1	1	1.5–2	Minor type of conjugate joint

Table 16-4: Rock Quality Index and Rock Quality Parameters

Rock Type	Q'		RQD	
	Mean	Standard Deviation	Mean	Standard Deviation
U1	42.7	58.8	69.3	20.4
U2	36.73	52.29	66.13	23.09
U3.3.0	38.28	59.27	72.95	22.40
U4.2.0	33.09	53.13	70.52	23.22
U4.3.0	25.80	40.06	67.23	25.61
U4.4.0	30.43	53.34	70.92	24.80
U4.4.1	17.53	33.66	66.84	21.69
U5.1.2	17.42	32.01	63.72	25.74
U5.1.3	23.97	40.91	66.42	25.40
U5.1.4	10.86	18.14	60.15	26.12
U5.2.1	19.07	35.15	67.29	23.55
U5.4.0	21.35	33.79	65.78	23.26

Table 16-5: Major Seismic Events in 104 Central Infrastructure Corridor

2013-08-31	104-08*	N/A	2.2
	104-08*	N/A	3.0
2015-01-22	104-06*	1.6	2.8
	104-06*	1.4	2.7
2015-05-26	104-06	2.1	3.2
	104-03	1.8	2.7
2015-05-27	104-10	1.9	2.4
2017-09-10	132-02	1.2	N/A
2018-12-22	Upper western side of 260, 132-10		3
2020-10-30	132-2,4,5	2.8	3.7

Note: N/A = not applicable. * = estimated.

These factors significantly increase the complexity of mine design, require additional resources, and increase the risk. Stope dimensions are limited by expected dilution while development configurations are limited by the induced stress state and other components of seismic hazard.

Mining methods will continue to be refined as mining experience is obtained. Ground support patterns as well as dilution and recovery rates are included in the mining plan according to current and expected performance, and will be updated as required.

16.2.1.6 Geotechnical Risks

Geotechnical considerations will continue to have a significant impact on the production plan of the Westwood Mine. In-depth geotechnical analyses were performed by mine staff and external consultants to identify risks associated with mining sequence, infrastructure location, and support requirements. Following the 2020 seismic events, design guidelines were completely revised and the geotechnical risk management program advanced. This program will continue to be updated as more experience is gained.

The identified geotechnical risks at Westwood mine are as follows:

- Large seismic events causing rock ejection, and ground falls associated with seismic vibrations;
- Small seismic strain bursts, causing rock ejections.

The above risks could result in injuries, loss of infrastructure, equipment damage, or complete closure of mining openings if the seismic algorithm is not applied properly.

16.2.1.7 Geotechnical Design Tools to Identify Geotechnical Risks

The general ground control approach is based on an array of mitigating measures that address a range of topics. Individual control measures all have uncertainty and limitations, and it is therefore preferable to meld numerous procedures together to build a robust management of risk, such that the approach is multi-faceted and does not rely on a single method or tool. Importantly, this multi-pronged approach is also a dynamic process: the inputs can evolve (by adding, eliminating, and/or combining criteria), the criteria and weighting associated with each can be adjusted as more data are collected and back-analyses are completed. In future, existing drifts, new stopes and development in high-risk zones will follow the flowsheet provided in Figure 16-1.

16.2.1.8 Approach Strategy

The strategy being implemented is summarized in Table 16-6.

Figure 16-1: Geotechnical Risk Management Flowsheet

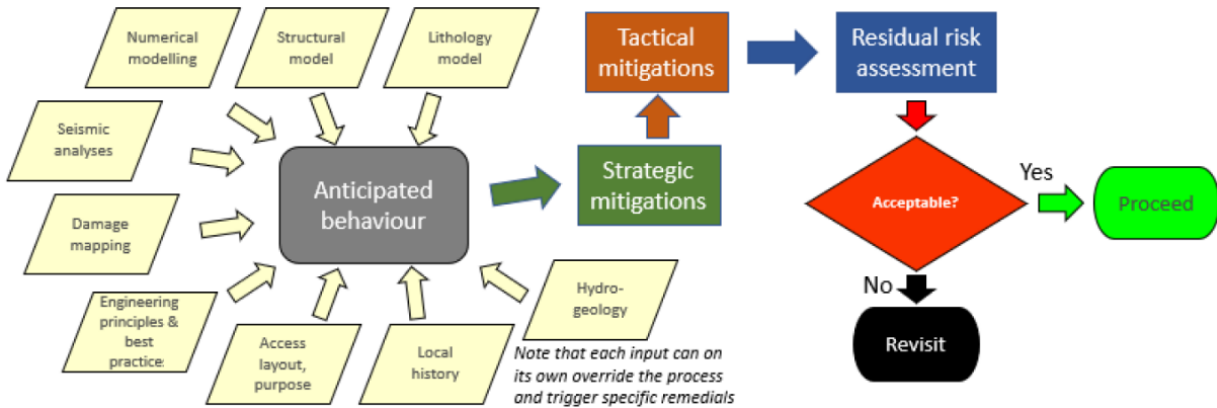

Note: Figure prepared by IAMGOLD, 2024.

Table 16-6: Risk Assessment Strategy

Area	Undertaking	Discipline
Enhancing the understanding of the mine environment	Geological assessment	Structures and discontinuities Lithology Hydrology and hydrogeology
	Geotechnical response	Strength Stiffness/ductility Failure properties
	Stress analysis	In-situ Mine induced
Practical understanding of past seismic events		Root cause & contributing factors analysis of historic events Seismic mechanism evaluations Damage assessments
Numerical assessments	Numerical modeling (large and smaller scale)	Calibration to mine data and assessments, and micro seismic data Mine plan evaluation and strategic adjustments
	3D hazard mapping (Hazmap)	Collection and merging of multiple data sets (mine plans, geology, structure, modeling, seismicity, ground movements, ground support, rate of extraction, etc.) Spatial and chronological analysis of risks and data

Area	Undertaking	Discipline
Assessing data		Enhanced seismic evaluations Damage mapping

16.2.1.9 Mitigation Plans

A variety of mitigation measures were developed and applied following mine re-opening in June 2021. The mitigation measures are summarized in Table 16-7.

The highlights of the mitigation plan were presented to the investigation committee during their final review of the investigation project in September 2021. The investigation committee endorsed the general plan, which relies on multiple approaches and the recognition that strong tactical mitigating measures will remain essential throughout the LOM plan. Based on the information presented, it is clear that the level of risk has been significantly reduced, but some residual geotechnical risk will always remain, particularly in the central zones. The residual risk is largely due to the complex local lithological and structural settings, and the high stresses found at depth.

The investigation committee endorsed the application of the seismic hazard algorithm in assessing and mitigating the risks associated with the central zones. The algorithm is also applicable to all seismic zones. Detailed risk assessments will be completed during the detailed designs of such areas to evaluate the residual risk after strategic and tactical mitigations are applied.

In the event that the residual risk has not been lowered to within IAMGOLD's risk tolerance, drastic control measures may be required, including, but not limited to, the closure and removal of the area from the mine plan.

Table 16-7: Mitigation Planning

Measure Type	Measure	Note
Strategic measures (engineered measures applied during the mine design process)	Mining rate controls	To allow the rock mass to dissipate the energy released following mining blasts.
	Mining sequence	This allows for optimal mining extraction sequence to improve safety as well as production and profitability. The mining sequence has been assessed using advanced numerical modeling (see Figure 16-1).
	Escapeways	The construction of multiple escapeways allows for a quick rescue of personnel in the event of entrapment due to ground conditions
Tactical measures (operational changes and/or practical solutions to reduce risk)	Dynamic rock support	The dynamic ground support allows areas to stay open and accessible following a seismic event, due to increased yield strength which avoids total failure. The selections are based on industry benchmark assessments, the stress modeling results, structural modeling, seismic analysis of previous events and the Canadian Rock Burst Research Program
	Seismic monitoring	Advanced seismic analysis has been performed and will continue. The analysis permits the establishment of hazard classifications for the different faults at the mine and will reduce employee exposure through the application of: <ul style="list-style-type: none"> • Cool down periods following a blast; • Early warning/ evacuations; • Blast rate reductions and exclusions zones
	Equipment improvements	The exposure of workers to the hazards has been improved by the creation of Enhanced Reinforced Cabins for various mobile equipment. New technologies such as tele-operated scoops (AutoMine) and wireless explosives are also being deployed to reduce the exposure of workers to deteriorating ground conditions.

16.2.1.10 Ground Support Considerations

Dimensions for waste drifts are generally 4.5 m high and 4.1 m wide, the exception being the planned Z230B zone that measures 4.5 m high x 4.5 m wide.

Drift dimensions in the ore lenses may vary locally according to the dip, width of the vein, and mining method selected; planned drifts dimensions are 4.5 m high x 4.5 m wide for long hole drifts with the exception of WW28, where certain ore drives are planned at 5.0 m high x 4.5 m wide.

Vertical development, such as ventilation raises and material handling (ore and waste) passes, are typically inclusive to infrastructure development. Dimensions are typically 2.4 m x 2.4 m, although the primary ventilation raise can reach up to 4.3 m in diameter. Raises are typically excavated with raise-bores to reduce exposure to workers.

Arched backs are promoted for lateral development to enhance ground stability. Ground support varies significantly depending on the expected ground conditions and combination of static ground support (rebar), yielding supports (hybrid bolts, de-bonded cables), long anchors (cable bolts) and dynamic support are used to control the wide spectrum of ground conditions experienced. In additions, mesh panels, straps and shotcrete are used either individually or conjointly as surface support.

Seismicity is monitored throughout the mine. IAMGOLD implemented a micro seismic system in 2013 to provide mine-wide coverage, with about 100 sensors installed at the Report effective date. Regular underground inspections and audits are performed as part of the geotechnical quality assurance and quality control programs. Ongoing monitoring of the ground support performance or possible deterioration are achieved by conducting routine workplace inspections by both technical services and operations personnel.

16.2.1.11 Approach Outcomes

Since the October 2020 event, extensive geotechnical studies have been completed, with the aim of evaluating all geotechnical aspects for the western, central and the eastern zones.

Following the application of the different mitigation plans, the mine experienced a significant drop of the seismic events shown in Figure 16-2.

Figure 16-2: Westwood Seismic Events History

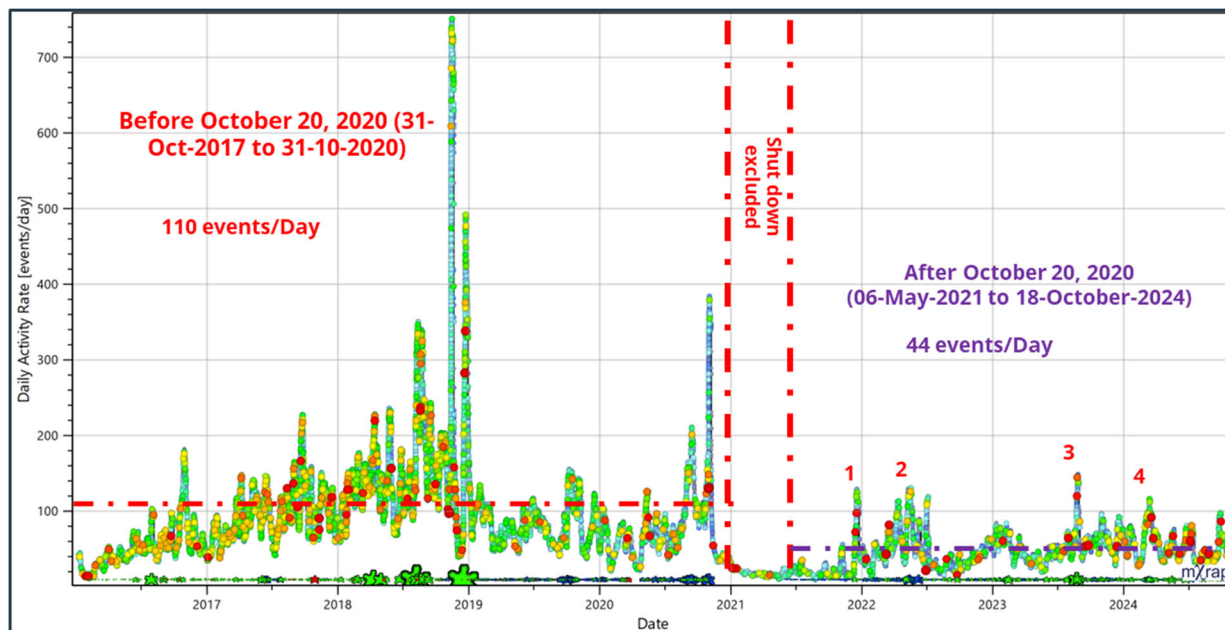

Note: Figure prepared by IAMGOLD, 2024

Key items to note from that figure include:

- The average number of events per day before October 20, 2020, is around 100. This average has remained relatively consistent over time;
- The current average (after October 20, 2020) is 42 events per day.
- The seismic activity rate appears to have been reduced by half, which represents a significant decrease;
- This reduction is mainly attributed to changes in mining practices including:
 - Mining sequencing;
 - The extraction rate;
 - Mine planning based on the seismic potential of different areas (implementation of the geo-seismic strategy).

Significant variations in the rate of seismic activity were observed after the event of 30 October, 2020 (1, 2, 3, and 4). However, these variations remain very low compared to those before 30 October, 2020. The maximum number of events in the current variations is around 150, compared to 300 to 700 events before 30 October, 2020. This reduction in the rate of seismic events is explained by the implementation

of mitigation measures evaluated according to the seismic potential and seismic response analysis of each zone (geo-seismic strategy).

16.2.2 Hydrological Considerations

The water management system in the Westwood underground operations is constantly under review to ensure that the needs for each mining corridor are addressed. The pumping system concepts and plans are peer reviewed within the IAMGOLD engineering department, and were independently checked in 2020 by third-party consultants BBA.

Water ingress is managed using a combination of sumps, pumps and drain holes to drain water to the main pumping system, which then pumps the water to the surface. The water is then discharged to the main water treatment system.

The majority of suspended solids are separated out of the water using the main separation system on the 1320 Level. The upper level main pump stations are on Levels 1320, 840 and 360. Water pumped to surface is relatively clear, and can be sent directly to the water treatment facility. Water from lower elevations within the mine, which has a significant particle load, is sent to a separate pumping system on Level 1320, which can handle the high solids content and abrasive nature of the lower mine waters.

A hydrostatic plug was completed in 2014 on Level 840. This corresponds to the Doyon Mine Level 014, which was used as exploration and development access for Westwood. The hydrostatic plug physically separates the two Doyon and Westwood mines and allows for disposal of Westwood tailings in the Doyon pit (refer to Section 20). The Doyon shaft has been decommissioned.

16.2.3 Operations

16.2.3.1 Mine Designs

The mining method used in LOM planning is long-hole open stoping. The majority of the stopes will be mined in a bottom-up pillarless manner for better stress management; in areas already developed or above Level 1040, the mining method will remain a bottom-up pillarless or primary-secondary long-hole open stoping mining method.

The transition from the primary-secondary method to a pillarless method is the result of a geotechnical study conducted after the major seismic event on October 30, 2020, which recommended using a pillarless approach with a sequence designed, generally, to move stresses away from the mining front unidirectionally (Figure 16-3 and Figure 16-4).

Figure 16-3: Former Mining Method, Westwood

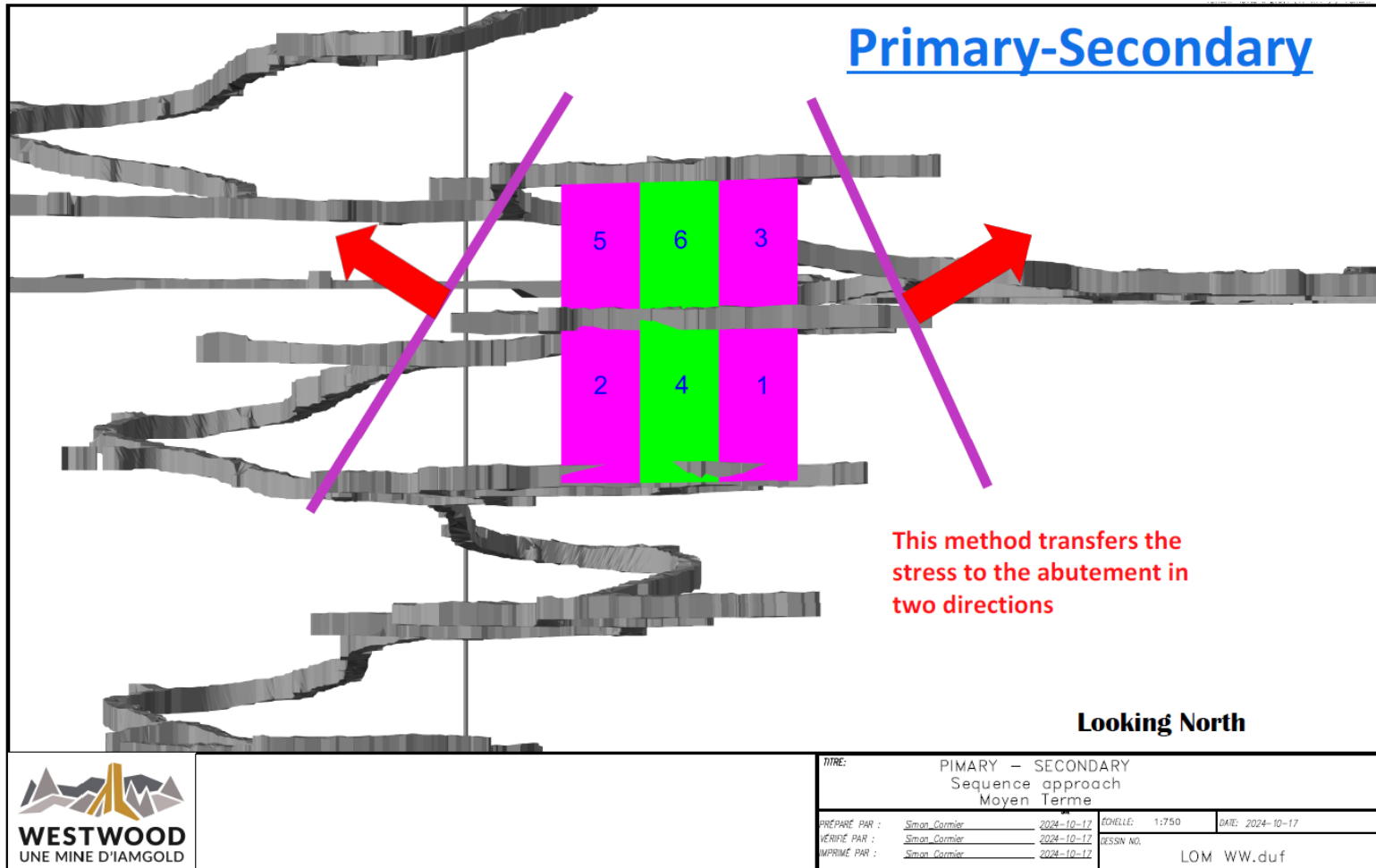

Figure 16-4: Current Mining Method, Westwood



The mining strategy is to mine the East, Central and Western sections of the mine simultaneously with as many as six mining areas mined concurrently to minimize production risk should one section be impacted by seismicity for a prolonged period of time.

Consideration has been applied in the LOM to mitigate colliding mining fronts, as they create diminishing pillars that are detrimental to mine stability.

All designs are completed using the geotechnical seismic algorithm, and sequences are modelled prior to approval to assess stresses and risk levels.

16.2.3.2 Operations

Stopes are generally drilled down from the upper level with 114 mm diameter holes, with a planned drill pattern of 2.0 m (toe burden) x 2.0 m (toe spacing). One production slot raise is required per stope.

Stope blasting is carried out with emulsion explosives and electronic detonators, with two blasts typically required for an average 4,500 t stope (see also discussion in Section 16.2.6). Wireless detonators are also used to reduce exposure of workers to the stopes once mining has commenced.

Load-haul-dump (LHD) units, equipped with remote capability, muck out the stope, with material being transferred to a haul truck, ore pass, or nearby re-muck bay. After the stope has been fully mucked and declared empty by the engineering department, using a cavity monitoring system or other surveying technology, it is filled with paste backfill to promote ground stability and minimize the induced seismicity.

A cure period of 21 days for the stope body is required before mining any adjacent stope and 28 days before excavating in paste.

16.2.3.3 Infrastructure

The key infrastructure for the underground operations is summarized in the following sub-sections. A mine layout plan is provided in Figure 16-5.

16.2.3.3.1 Access

16.2.3.3.1.1 Shafts and Ramps

Underground access is by a 6.4 m diameter circular shaft with a current length of 1,958 m. Main levels (shaft access) are spaced approximately 240 m apart; the majority of underground infrastructure, including maintenance facilities, warehouses and stockrooms, and electrical stations, are located on these levels. Levels 840, 1320, and 1800 include track drifts designed for ore/waste handling by trolley as well as crushing and loading infrastructure. Other tramming levels will be added at depth as needed for operations such as the Level 1560 exploration drifts. Sub-levels usually include electric sub-station, paste-bay, refuges, stockrooms, and drilling bays. There are always two safety exits from each sub-level, a safety precaution introduced after the October 2020 seismic event.

The Warrenmac ramp was developed from surface to access the ore zones and is connected to the Westwood internal ramp network. Sub-levels used for mining are spaced approximately 25–30 m apart. A series of ore and waste passes are placed throughout the mine.

16.2.3.3.1.2 Headframe

The 85 m tall headframe provides the structure for the production, service, and auxiliary hoists. All hoists have sheaves. Bridge crane and trolley hoists are used for maintenance and material movement. The ore-bin and loading building, in addition to the compressor building, are annexed to the headframe. The proximity of the compressor building could eventually permit heat generated in the mine ventilation system to be recovered.

16.2.3.3.2 Hoisting

The hoist building comprises four main areas, auxiliary hoist, production and service hoists, electrical room, and emergency generators. Both auxiliary and services/production hoists sections have bridged cranes (15 t and 55 t, respectively) to allow maintenance.

The auxiliary hoist is a 4.57 m diameter x 2.34 m wide single drum refurbished hoist with a payload of 1,100 kg. It serves primarily to transport personnel and as an emergency exit.

The production hoist is a 6.4 x 2.4 m double-drum hoist with a payload of 20,000 kg, and is uses two 20 t skips to hoist ore. The service hoist is a 5.8 x 2.4 m double-drum hoist with a capacity of 10,000 kg. It is used to transport workers and material underground.

A 25 kV secondary substation is located near the hoist room, in addition to a 1,500 kW diesel generator in case of electrical failure. The diesel generator has the capacity to operate the auxiliary hoist, as well as provide emergency lighting, pumping, and other essential services.

16.2.3.3.3 Material Handling

Ore and waste are transported by LHD units to the nearest raise, usually less than 300 m away. For longer distances, 20- and 30-t trucks are used. All materials travel through a network of ore and waste passes to Level 1320 or Level 1800, where the trolley systems are located. Electric trolleys transport materials from the various raises to the loading infrastructure for hoisting. The trolley system consists of 10 wagons, each weighing 7 t and with a daily capacity of 4,200 t/d. The wagons are dumped into another network of raises to reach the loading pockets located on Levels 1400 and 1920. Two 20-t skips are used to hoist materials to the surface. Total hoisting capacity depends on the location of the loading pockets, but the LOM plan assumes a total hoisting rate of 3,000 t/d. Once at surface, the ore is transported by 30-t trucks to the Doyon processing plant, a distance of approximately 2.5 km, or to the waste rock storage facility (WRSF).

16.2.3.3.4 Ventilation

Fresh air is brought underground through the main intake air raise (6.4 m diameter) and the main shaft (6.4 m), and then distributed to the lower levels of the mine via a series of raises. The active mining blocks are then ventilated in series of ramps extending up the mine. Exhaust air is ultimately removed from the mine through the primary return air raise and the Warrenmac ramp.

Two 400 hp fans in parallel setting are located at Level 360 and two additional 400 hp fans are installed at Level 600.

The main fan station provides the required airflow in a push-pull ventilation arrangement, for a total air movement of 535 kcfm.

A ventilation schematic is provided in Figure 16-6.

Figure 16-6: Ventilation System Layout Schematic

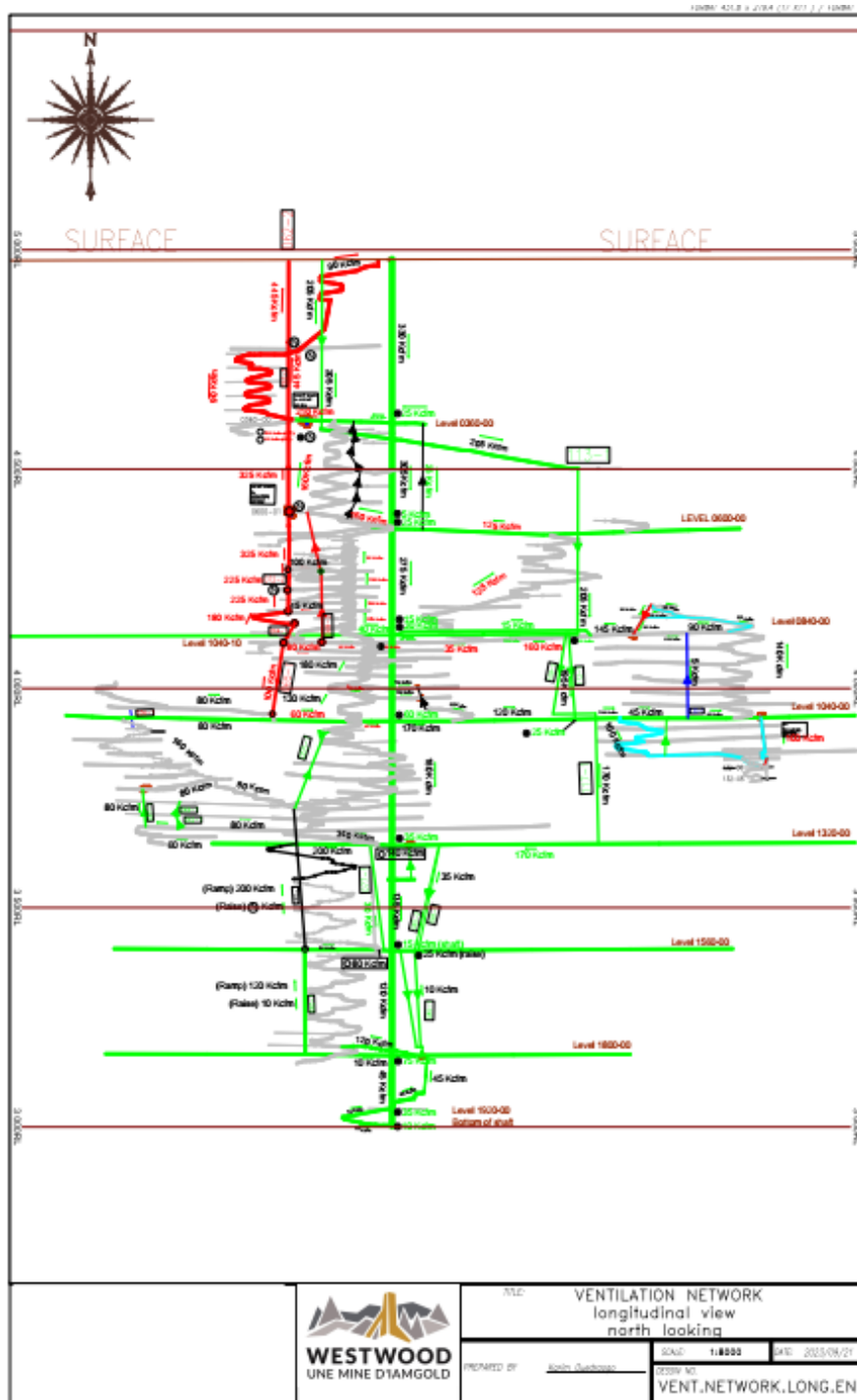

Note: Figure prepared by IAMGOLD, 2024.

16.2.3.3.5 Backfill

Cemented paste backfill is the primary backfill type used at Westwood. Paste is generated from a mixture of tailings slurries and cement. A blend of 10% general purpose cement and 90% tailing slurry is used in paste production. The resulting paste is delivered via a gravity distribution system from surface to underground via three paste boreholes and to the stopes through a system of 15 cm (6 inch) diameter pipes. The network extends from surface down to Level 360, where it splits to feed the eastern, central, and western production corridors.

A maximum feed rate of 70 t/h is typically used. However, the LOM plan assumes a net daily feed rate of 634 t/d due to a combination of workforce and paste mill availability.

Uncemented rockfill is occasionally used for filling the last stopes in a mining sequence.

A schematic showing the backfill system layout is provided in Figure 16-7.

16.2.3.3.6 Compressed Air

Compressed air for underground operations is provided by seven high efficiency screw compressors, each with a capacity of 57 m³/min at 760 KPa (2,000 cfm at 110 psi) for a total capacity of 400 m³/min (14,000 CFM). This set-up includes pressure tanks. Power is drawn from the electrical substation attached to the hoisting room.

16.2.3.3.7 Fuel Storage

A fuel storage area is located near the Westwood headframe installation. Two fuel tanks provide a capacity of 45,000 L of diesel and 9,000 L of gasoline. The diesel tank is connected to the underground fuel distribution network and is available for fuelling mobile equipment on surface. Containment measures are installed to meet environmental regulations.

16.2.3.3.8 Emergency Egress

Following the re-opening of the mine in 2021, it was decided to provide an additional emergency egress on active production levels. Prior to production, a vertical raise is drilled with a raise bore to connect levels. A tubular escape way, with ladders and fall arrest system is then installed and cemented in place for use in the event of an emergency.

Figure 16-7: Backfill System Layout Schematic

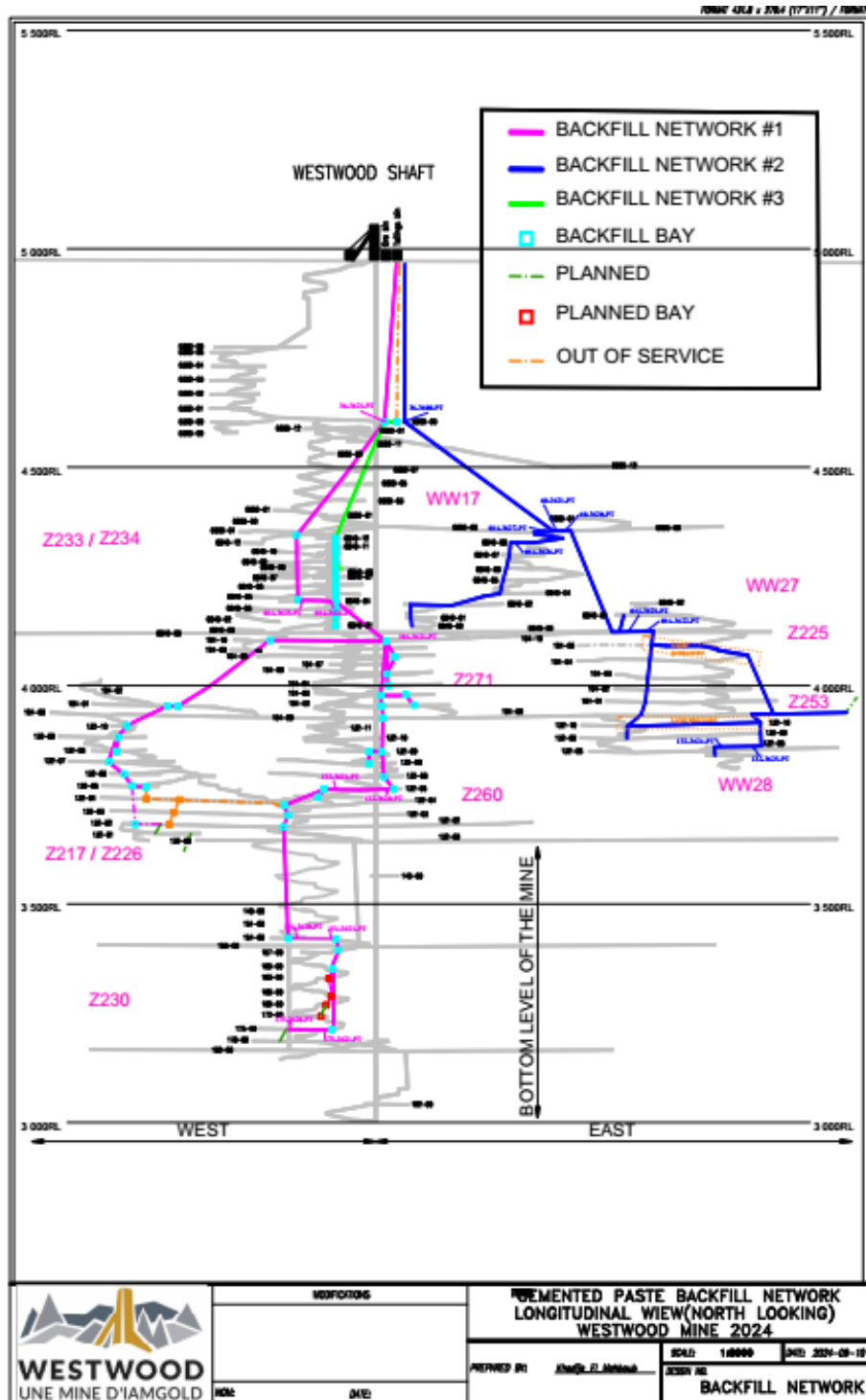

Note: Figure prepared by IAMGOLD, 2024.

16.2.4 Life-of-Mine Plan

Mine life forecasts, based on Mineral Reserves, are scheduled for 2025–2032 for budgetary purposes, but use the same Mineral Reserve forecasts for the fourth quarter of 2024. A longitudinal section of the mine was provided in Figure 16-5.

The combined Westwood and Grand Duc LOM plan, which includes production from stockpiles, provides for an overall production of approximately 4.0 Mt grading 7.51 g/t Au for a total production estimate of 0.98 Moz Au (Table 16-8).

16.2.5 Ore Control

In 2023, the Westwood technical service team commenced using borehole trackers to increase the drilling quality control.

Production hole breakthroughs are surveyed to provide information that will allow for adjustment of the blasting sequence or to identify when additional drill holes are required to meet blasting factors.

Drone or cavity monitor surveys of the open stopes are used in engineering calculations such as mine recovery and overbreak.

Table 16-8: LOM Plan, Westwood and Grand Duc

Item	Units	2025	2026	2027	2028	2029	2030	2031	2032
<i>Westwood</i>									
Ore mined	kt	351	346	370	373	374	359	275	48
Grade mined	g/t Au	11.04	13.25	11.86	10.60	11.29	10.20	12.68	13.62
Ounce mined	koz Au	125	147	141	127	136	118	112	21
Lateral development	m	5,712	4,737	4,806	4,523	3,381	2,927	110	—
Waste mined	kt	243	200	205	197	110	106	2	—
<i>Grand-Duc</i>									
Ore mined	kt	1,129	—	—	—	—	—	—	—
Grade mined	g/t Au	1.10	—	—	—	—	—	—	—
Ounce mined	koz Au	40	—	—	—	—	—	—	—
Waste mined	kt	1,059	—	—	—	—	—	—	—
<i>Mill</i>									
Ore milled	kt	1,075	1,088	449	373	374	359	275	48
Grade milled	g/t Au	4.52	4.67	9.89	10.60	11.29	10.20	12.68	13.62
Ounces milled	koz Au	156	163	143	127	136	118	112	21
% recovery	%	94.0	94.4	95.0	95.0	95.0	95.0	95.0	95.0
Ounce produced	koz Au	147	154	136	121	129	112	107	20

Note: numbers have been rounded.

Muck scoop samples are sampled by the geologists at a typical frequency of one sample per four buckets.

Regular field visits are conducted by the geology team to observe the quality of material at development faces and muck piles, and to manage re-mucks.

16.2.6 Blasting

The explosives contractor is Orica, which supplies both bulk and stick-type emulsions. Orica supervises production loading, timing, and blasting. From 2022, wireless electronic detonators (Webgen) have been used to improve the blasting sequence, blasting flexibility, and reduce worker exposure.

Development blasting is completed by company personnel using bulk explosives.

16.2.7 Equipment

The LOM equipment requirements are summarized in Table 16-9.

Table 16-9: Equipment Requirements, Westwood

Unit	LOM Requirements
Jumbo drill	4
Bolter	12
Scissor lift	9
Scoop	10
Trucks	12
Production/cable drill	5
Man carrier	28
Locomotive (8 t)	3
Excavator	5
Grader	2
Transporter	2
Boom truck	4
Shotcrete/concrete sprayer	1
Shotcrete/concrete transmixer	2

IAMGOLD have introduced AD22 trucks and 6 yd³ scoops to support production goals and reduce maintenance. A Simba E70 drill rig was purchased to improve drilling production rates and support stope sequencing optimization.

The IAMALLIN improvement project included initiatives that enhanced equipment availability and maintenance planning.

16.3 Grand Duc

16.3.1 Geotechnical Considerations

Geotechnical assumptions are based on the safety factors and failure probabilities typically used in the mining industry as an acceptance criterion for slope design, as suggested by Read and Stacey (2009), as well as the requirements of the Mining Occupational Health and Safety Regulations.

Several failure mechanisms were investigated to quantify the local stability of the benches, benches forming the inter-ramp slope as well as ruptures of greater magnitude associated with the overall slope of the pit.

The mechanisms considered are:

- Toppling failure (direct and bending);
- Slip failure (planar or dihedral);
- Circular or semi-circular fracture, especially for the fractured area near the surface;
- Coupling of different failure mechanisms.

The pit walls were analyzed at dip direction intervals of 20° from 50° to 270. Bench face angles of 70°, 75° and 80° were analyzed. Residual friction angles obtained from direct shear test results were evaluated and an average friction angle of 40° (mean) was obtained. To be conservative, all available data on the structures were compiled and analyzed assuming that any structure could be located anywhere along the south wall of the pit.

For berm sizing, analysis based on rigid body dynamics was performed using Trajec3D software (Basroc, 2020). The simulation parameters are as follows:

- “Restitution” coefficients: 0.1 and 0.2;
- Bench angle: 80°;
- Static friction angle: 40°;
- Dynamic friction angle: 35°;
- Block geometry: “flat elongated box shape”;
- Block masses: 1, 5 and 10 t;
- Berm widths: 6 and 8 m;
- Heights: 10, 15 and 20 m;

Simulations performed indicate that berm dimensions according to Ritchie’s Modified Criterion are suitable for current design. The use of 8 m berms would be sufficient to retain more than 96% of blocks of 10 t or less. The analysis considered only an 80° angle, which was considered the highest risk case. A lower angle will further increase the percentage of berm block retention.

Therefore, the pit slope parameters summarized in Table 16-10 were designed by IAMGOLD staff and a third-party contractor, Entech Pty Ltd.

A variety of monitoring techniques is implemented to monitor and manage slope stability and monitor the design performance.

Table 16-10: Geotechnical Parameters, Grand Duc

Location	Bench Height (m)	Bench Face Angle (°)	Spill Berm Width (m)
North wall	10	70	9
	10–20	70	7–10
South wall	10	70	9
	10	75–70	9
	10–20	75	7–10

Monitoring currently includes:

- Installation of prism monitoring network to follow up wall stability on a monthly basis;
- Daily visual inspection of the pit walls;
- Crack monitoring using extensometers;
- Live monitoring of the north wall. Conducted using Geomos, with the system housed in a cabin located at the crest of the southwest wall. Data are collected in real-time.

16.3.2 Hydrological Considerations

Water management in the pit is provided by a Pioneer PP86S17 pump, installed in the sump at the deepest point of the mine. The pipe runs 75 m down the vertical north wall and along the 600 m-long ramp to the north of the pit. The mining contractor owns and maintains the pump.

Water is conveyed to the north park via a 20 cm (8") diameter pipe. The pump has a maximum capacity of 1,240 m³/h and a maximum head of 140 m, which will be sufficient for LOM requirements.

16.3.3 Operations

16.3.3.1 Mine Designs

The open pit is designed to reach a total depth of 110 m, and will be about 309 m long. A final pit plan is provided in Figure 16-8.

Figure 16-8: Final Pit Layout Plan, Grand Duc



Note: Figure prepared by IAMGOLD, 2024.

Benches are designed on 10 m heights in overburden and 20 m heights in fresh rock. Berm widths are 20 m in overburden and 10 m in fresh rock. Ramps and roadways are typically 20 m wide, reducing to single-lane, 12 m, widths at the base of the pit. Ramps typically have a gradient of up to 10%. The pit entry ramps undergo weekly engineering safety inspections.

16.3.3.2 Operations

The open-pit mining cycle includes:

- Drilling and blasting of ore and waste;
- Ore loading and hauling to the process plant for processing, or is stockpiled depending on the feed from the underground operations;
- Waste rock loading and hauling to a designated WRSF.

16.3.3.3 Infrastructure

Overburden material is disposed near the Grand Duc open pit, and waste rock is deposited on the north pad. The waste rock storage facilities are discussed in Section 20.5.

The Grand Duc operations share a portion of the infrastructure required for the mining operations with Westwood, including the Doyon process plant and tailings storage.

16.3.4 Ore Control

Grand-Duc uses blast monitoring movement technology to monitor the movement of blasts. This allows segregation of high-grade and low-grade ores from each other, and waste rock, before shoveling.

Sample drilling is completed before production drilling to refine tonnage and grade estimates. Sample holes are drilled to a length of 20 m at a 60° angle.

16.3.5 Blasting

Grand Duc uses different drill pattern depending on the materials and where in the pit the pattern is to be drilled. Typically, a 2.89 x 2.89 m pattern is used for ore blocks to optimize fragmentation prior to primary crushing. Waste holes are completed on a 3 x 3 m pattern. Drill holes are usually 10 m long, and have a 10 cm (4 inch) drill diameter.

Emulsion in bulk is used for all blasts, independently of materials and cartridges for presplit.

Wipfrag is used to analyse the fragmentation performance of ore blasts, and guide the improvement direction.

16.3.6 Life-of-Mine Plan

The mine production schedule aimed to maximise the grade at the mill while balancing the ore tonnage production with the Westwood underground production for a steady mill feed.

The remaining mine life is one year, from 2024–2025, assuming a 240,000 t/month average production rate at a 0.54 g/t Au cut-off.

The LOM plan for the operations was provided in Table 16-8.

16.3.7 Equipment

All production equipment is provided by the mining contractor, from production drilling to bulldozers. The LOM equipment list is summarized in Table 16-11.

Excavation is currently being carried out with shovels combined with Komatsu HD325 (40T) trucks, a practice IAMGOLD plans to continue for the duration of the LOM plan.

Drilling is completed using Sandvik DX800 and DX900 drill rigs. A spare Sandvik DX500 drill is on standby in case one of the main drills breaks down to ensure production can continue.

Operations use two shovels for production and one service shovel for scaling, bench preparation, and various other needs. Drill rigs are mainly used for production drilling, but can also be used for sample drilling. The DX900 drills are also used for perimeter holes.

A loader is primarily used to feed the primary crusher on the ore pad and to load trucks during rehandling from the pad to the mill. A bulldozer is used on the overburden, ore, and waste pads.

Road quality is ensured by two graders, one as a spare. A water tank used to control dust during the summer months.

Table 16-11: Equipment List, Grand Duc

Type	Equipment	LOM Required Quantity
Shovel	Komatsu 650	1
	Caterpillar 374	1
Truck	Komatsu HD325	8
	Caterpillar 740	2
Loader	Caterpillar 980	2
Bulldozer	Caterpillar D8t	2
Water tank	Komatsu HM 300	1
Shovel	Caterpillar 395	1
	Volvo 480	1
Truck	Volvo A40	1
Grader	Volvo	2
Drill	Sandvik 900	2
	Sandvik 800	2
	Sandvik 550	1

17 RECOVERY METHODS

17.1 Introduction

The metallurgical testing presented in Section 13 supports the process design criteria and the Doyon mill flowsheet.

The process plant was originally constructed in the 1970s and last refurbished in 2013 to increase throughput to 1.0 Mt/a. Upgrades were made to the grinding, cyanidation, strip, and tailings cyanide destruction circuits. A new paste backfill plant was also built to meet the Westwood Complex operational needs.

The plant has been operated both continuously, and in batch mode, since 2013, depending on ore availability. Currently, operations are 24 hours a day, seven days a week, 52 weeks a year. However, there will be portions of the current mine plan which will see reduced ore availability, and the plan is to have the plant operate in batch mode. Depending on the period, this may result in selected weeks in a month operations, or 3–4 days in a week operation.

There have also been instances over the plant history where the process plant toll-treated custom material from other mining operations. This remains an option since the process flowsheet is flexible and can accommodate third-party custom materials outside the LOM plan.

17.2 Flowsheet

The Doyon plant treats ore via a conventional cyanidation process. Run-of-mine (ROM) ore is processed using a conventional single stage primary crusher followed by a two-stage semi-autogenous grinding (SAG) mill and ball mill grinding circuit, gravity circuit, pre-leach, carbon in leach (CIL) and carbon in pulp (CIP) circuits, in addition to associated gold recovery and carbon handling circuits to produce gold/silver doré.

Figure 17-1 shows the grinding, leaching, adsorption, and stripping circuit, Figure 17-2 illustrates the cyanide destruction and paste backfill circuits, and Figure 17-3 provides the flowsheet for the water and tailings management circuits.

Figure 17-1: Grinding, Leaching, Adsorption and Stripping Circuit

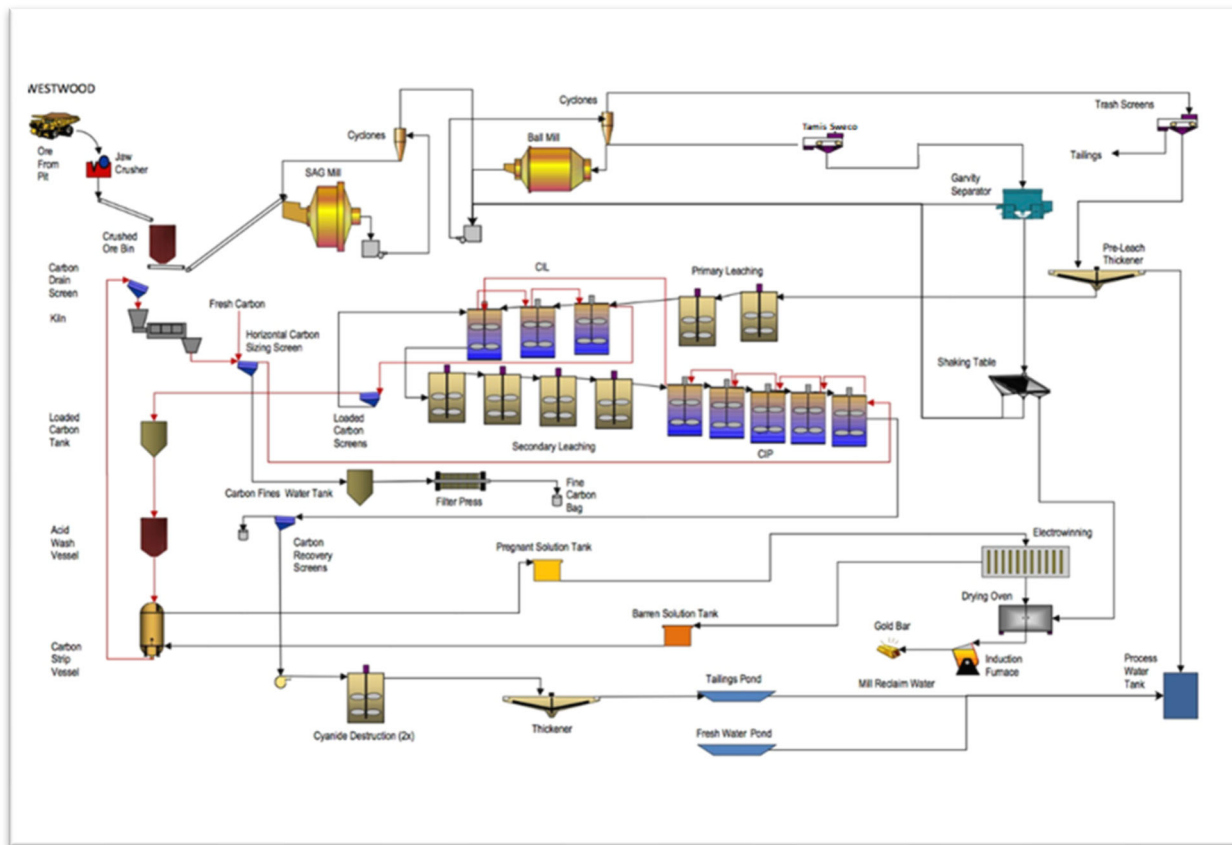

Note: Figure prepared by IAMGOLD, 2022

Figure 17-2: Cyanide Destruction and Paste Backfill Circuits

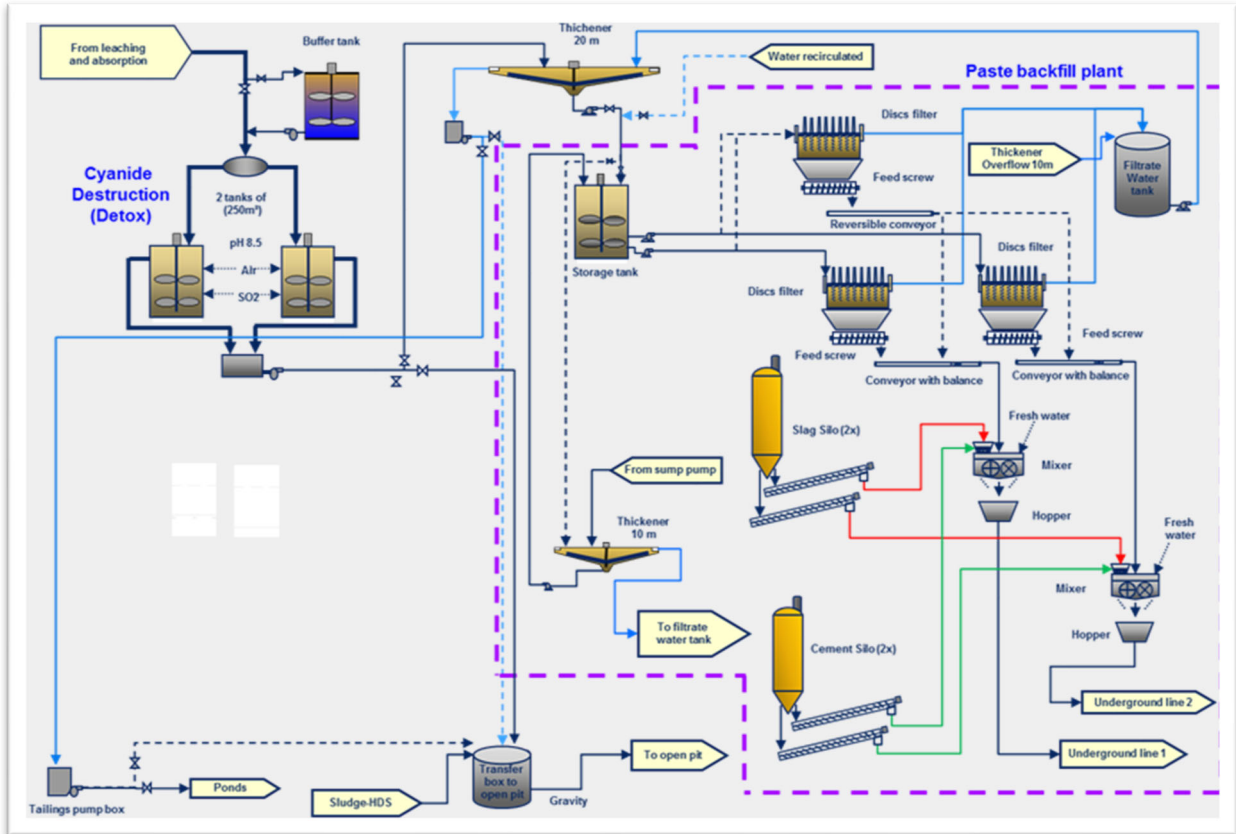

Note: Figure prepared by IAMGOLD, 2022

Figure 17-3: Water and Tailings Management

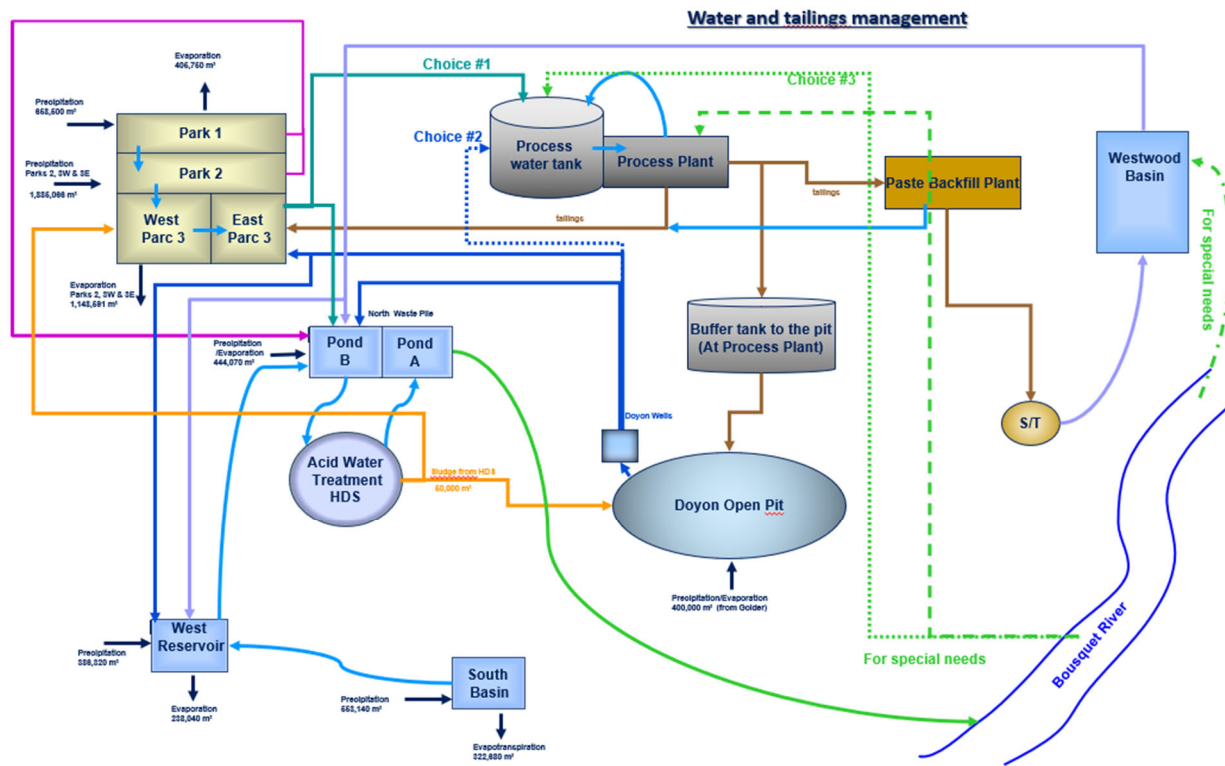

Note: Figure prepared by IAMGOLD, 2023

17.3 Plant Design

17.3.1 Ore Handling and Crushing

Underground ore is hoisted to surface and hauled by truck to the process plant located 2.5 km from the mine shaft, where the ore is discharged at the crusher house. Ore is fed to a single stage jaw crusher (1.07 m x 1.22 m) by a front-end loader through a grizzly feeder. Ore is conveyed to the process plant ore bins using a belt conveyor system. Each bin has a capacity of 2,800 dmt.

17.3.2 Grinding and Gravity

Grinding of Westwood ore is achieved using a 2,700 HP SAG mill in closed circuit with primary hydrocyclones. The overflow from the primary hydrocyclones feeds a 1,000-HP ball mill in closed circuit with secondary hydrocyclones. A portion of the underflow (secondary hydrocyclones) feeds the gravity separation circuit composed of a Sweco screen, Knelson concentrator (30") and a shaking table. The tails

of the gravity circuit return to the grinding circuit and the gravity gold concentrate proceeds to the refinery. The targeted grind size is 85% passing 75 µm.

17.3.3 Leaching and Adsorption

The cyanide leaching circuit has 40.5 hours of retention time at the nominal processing rate of 3,106 t/d. Leach residue is sent to cyanide destruction. At the nominal processing rate, the retention time for each step of the leach and adsorption process is as follows: primary leach tanks (4.9 hours), CIL tanks (6.9 hours), secondary leach tanks (16.2 hours), and CIP tanks (12.6 hours).

17.3.4 Cyanide Destruction

Tailings are treated with a SO₂/air cyanide destruction process. Leach residues are split between to parallel reactors. During normal operation, a part of the process discharge residues is used to feed the paste backfill plant while the remainder is pumped to Doyon. A buffer tank (14 hours of backfill plant operation capacity) is maintained at maximum level with detoxified slurry to ensure continuous feed to the backfill plant in case of a temporary process plant shutdown.

17.3.5 Paste Backfill

Two lines, two kilometres in length have been installed between the process and paste backfill plants. One pipe is used to feed the paste backfill plant with tailings and the other returns water filtrate to the process plant. The design allows the pipes to be drained by gravity in case of breakage or power failure.

Two paste backfill circuits are available to provide flexibility in the preparation and distribution of paste to the stopes, i.e. ability to fill two stopes simultaneously with different recipes.

The mixture is prepared according to the backfill engineer's specifications. Though the backfill plant was designed to achieve a maximum production rate of 144.6 t/h, a nominal backfill rate of 70 t/h is required.

17.3.6 Gold Recovery

The gold desorption circuit is composed of an acid wash vessel and high pressure Zadra stripping reactors. Stripping is conducted by continuously circulating a hot (low concentration) sodium cyanide and caustic soda solution through the carbon stripping columns.

The electrowinning circuit is comprised of two parallel electrowinning cells. It produces a gold sludge, which is filtered, dried, and smelted into doré bars as a final product.

Carbon is reactivated through a regeneration kiln before being reintroduced into the CIL/CIP tanks. Fresh carbon is periodically added to the circuit.

17.4 Tailings Disposal

Tailings not used for paste backfill are pumped to the mined-out Doyon open pit for disposal (see discussion in Section 18.3).

17.5 Energy, Water, and Process Materials Requirements

17.5.1 Reagents and Consumables

The major reagents required in the plant include grinding media, quick lime, cyanide, oxygen, caustic soda, sulphur dioxide and slag/cement for paste backfill plant operation.

Two sizes of grinding media are used, 38 mm (1.5 inches) diameter for the ball mill and 133 mm (5.25) inches diameter for the SAG mill.

17.5.2 Plant Services

Two compressors with drying systems supply air services and instrumentation air for all of the process plant and surface utilities.

Two compressors supply process air principally for oxidation purposes in the leaching tanks. This air can be used as a backup system in the detoxification system to destroy residual cyanide in the tailings.

Oxygen is normally used in the detoxification system. The oxygen is supply by truck (liquid form) and is vaporized before injection in the bottom of the detoxification tank.

17.5.3 Power

Power is provided through the electrical network on site (see Section 18) and supplied by Hydro-Québec.

Annual power consumption for the process plant averages about 35–36 kWh/t. The current contract and installation provide sufficient electricity for the process plant operations for LOM purposes.

There is a generator set on site which can provide emergency power for lights and fire pumps.

17.5.4 Water

The plant requires about 1.1 Mm³ of process water annually, based on water useage in 2022–2023 and the first half of 2024.

While process water can be drawn from the Bousquet River when necessary, most water is reclaimed from the TSF and/or the Doyon reclamation water management system so as to minimize water pumping from the river. Water supply is sufficient for LOM purposes.

Fresh water and gland seal water is sourced from the Bousquet River.

An average of 4.0–4.5 Mm³ of water from the overall Westwood property is treated at a high density sludge plant annually before the treated water is released into the environment.

18 PROJECT INFRASTRUCTURE

18.1 Introduction

The Westwood Complex currently supports mining operations and a processing facility which operate 24 hours per day, seven days per week.

The main onsite infrastructure at Westwood and Grand Duc includes:

- Westwood underground mine: production shaft, Warrenmac ramp portal, hoist room, headframe; compressors water management systems;
- Grand Duc open pit mine;
- Doyon process plant;
- Mine services building: includes provision for general management, health, and safety, mine rescue, human resources, training, IT, technical services, environmental, mine operations personnel, dry facilities;
- Ventilation shaft and primary fans;
- Backfill plant;
- Waste rock storage facilities;
- Doyon in-pit tailings storage;
- Fuel bays and fuel storage;
- Main access road;
- Power supply (120 kV power line from Hydro-Québec);
- Natural gas line with gas supply by Énergir;
- Water systems (potable and domestic water supply, fire protection system, sewage disposal system);
- Tailings ponds;
- Effluent water treatment system.

A general infrastructure layout plan for Westwood is included as Figure 18-1. Figure 18-2 shows the infrastructure in the immediate vicinity of the Westwood Shaft. Figure 18-3 and Figure 18-4 present plan views of surface infrastructure within the Doyon and Grand Duc mining leases, respectively.

The Grand Duc technical staff and Projects teams are currently located in the administrative building at the entrance to the Westwood Complex. The Grand Duc Operations personnel operate out of a building adjacent to the administration building. Several laydown yards are located south of the Grand Duc open pit. This area is also used for parking and open pit mining equipment maintenance.

The accounting and purchasing offices are currently located in the city of Rouyn-Noranda.

The main surface warehouse is located near the maintenance shop. Surface storage space is provided for inventory and material management.

The fire protection system includes fire pumps, water distribution network, fire hydrants, and hose cabinets. Reclaimed underground process water is pumped to the surface polishing pond which also serves as a fire-water reservoir.

The waste water management system includes a sewage disposal system with septic tanks and seepage field.

Infrastructure at the former Fayolle open pit is in the reclamation process.

18.2 Roads and Logistics

Project access and haul roads are discussed in Section 5.2.

18.3 Stockpiles

Temporary stockpiles are located as follows:

- Outside the Westwood headframe: underground ore surplus prior to trucking to the mill;
- On the north side of Grand Duc: temporary storage and crushing of Grand Duc material prior to transport to the mill;
- On the west of the Doyon open pit: long-term storage of low grade material from Grand Duc which is planned to be milled following closure of Grand Duc;
- South of the mill: various piles for blending of material for mill feed.

Figure 18-1: General Surface Infrastructure Westwood–Grand Duc



Note: Figure shown at 1:10,000 scale.

Figure 18-2: Westwood Mine Infrastructure



Note: Figure shown at 1:2,500 scale.

Figure 18-3: Doyon Area Surface Infrastructure – Plan View



Note: Figure shown at 1:2,500 scale.

Figure 18-4: Grand Duc Surface Infrastructure – Plan View



Note: Figure shown at 1:2,000 scale.

18.4 Waste Rock Storage Facilities

WRSFs are discussed in Section 20.5.

18.5 Tailings Storage Facilities

Tailings disposal is discussed in Section 20.6.

18.6 Water Supply

Process water for the underground operation and the processing plant is supplied by reclaim water and water from the Bousquet River. IAMGOLD is actively evaluating water recycling and re-use options to reduce the operational reliance on surface waters.

Clean water is supplied from several 100 m deep groundwater wells, and is distributed to the mine buildings without treatment. Bottled water is used for drinking purposes.

18.7 Water Management

All water collected in the Westwood and Grand Duc areas is pumped to the water management system and treated in a high density sludge plant prior to discharge to the Bousquet River (see discussion in Section 20.2.2).

18.8 Built Infrastructure

All required infrastructure to support mining operations at Westwood and Grand Duc has been constructed and is operational.

18.9 Camps and Accommodation

The mine sites are drive-in, drive-out, with employees living in surrounding communities.

18.10 Power and Electrical

Electricity is supplied to the Westwood and Grand Duc mines via a 120 kV power line (Hydro-Québec), and is stepped down to 25 kV by two transformers. Each transformer has a nominal capacity of 20 MVA.

The Westwood Complex uses about 64–65 kWh/t of power annually, of which about 35–36 kWh/t represents plant requirements. The Westwood mining infrastructure is fed by a 1 km long 25 kV electrical line from the main 120 kV main substation.

The power supply is sufficient for LOM operations.

18.11 Natural Gas

Énergir supplies the natural gas used for heating the Westwood fresh air supply in winter and intake ventilation infrastructure.

19 MARKET STUDIES AND CONTRACTS

19.1 Market Studies

No market studies are currently relevant as Westwood and Grand Duc are operating mines producing a readily-saleable commodity in the form of doré.

Gold produced from the Westwood Complex is shipped from the mine site to the Metalor refinery in Massachusetts (USA) and sold at spot prices. The refining contract and sales schedules are managed by IAMGOLD at the corporate level, and include production from other operations. The terms contained within the sales contracts are typical and consistent with standard industry practice, and are similar to contracts for the supply of doré elsewhere in the world.

19.2 Commodity Price Projections

Commodity prices and exchange rates used in Mineral Resource and Mineral Reserve estimates are set by IAMGOLD corporately. For the purposes of this Report, the forecasts were:

- Mineral Resources:
 - US\$1,800/oz Au;
- Mineral Reserves:
 - US\$1,500/oz Au (Westwood);
 - US\$1,800/oz Au (Grand Duc);
- Exchange rate:
 - US\$:C\$: 1.25.

The higher metal prices used for Mineral Reserves at Grand Duc reflect the short mine life for that deposit.

19.3 Contracts

The Westwood mine has been in operation for a number of years and has several contracts in place to support operations. These contracts cover a large range of activities such as underground work, diamond drilling, laboratory testing services, maintenance and equipment repairs, security as well as bulk commodities and consumables. The terms of the contracts are within the mining industry norms.

All open pit mining is performed by a contractor. The terms of the mining contract are within the mining industry norms.

19.4 QP Comment on Item 19 “Market Studies and Contracts”

The doré produced, or planned to be produced by the operations is readily marketable.

Metal prices are set corporately for Mineral Resource and Mineral Reserve estimation. The higher metal prices used for Mineral Reserves at Grand Duc reflect the short mine life of that deposit.

The QP has reviewed commodity pricing assumptions, marketing assumptions and the current major contract areas, and considers the information acceptable for use in estimating Mineral Reserves and in the economic analysis that supports the Mineral Reserves.

20 ENVIRONMENTAL STUDIES, PERMITTING, AND SOCIAL OR COMMUNITY IMPACT

20.1 Baseline and Supporting Studies

The Westwood and Grand Duc Mines are located on the existing Doyon property. Given the long duration of mining at Doyon–Westwood, there is limited information on the type, nature, and duration of initial baseline studies. Complete or partial characterization studies were completed for climate, hydrology and surface water quality, hydrogeology, flora, fauna, soils, and land use. Currently, IAMGOLD is completing characterizations as, and when, new applications for environmental authorization are required. The available environmental studies documenting pre-existing conditions, together with the ongoing site environmental conditions monitoring, are used to support decision-making processes during operations.

Baseline and supporting environmental studies on the Fayolle property were completed to assess both pre-existing and ongoing site environmental conditions, as well as to support decision-making processes during operations start-up. Characterization studies were completed for climate, air quality, hydrology and surface water quality, hydrogeology, flora, fauna, soils, agriculture, and land use. Plans were developed and implemented to address aspects of operations such as waste and fugitive dust management, spill prevention and contingency planning, water management, and noise levels.

20.2 Environmental Considerations and Monitoring Programs

20.2.1 Site Management and Monitoring

The Westwood and Grand Duc environmental management systems are integrated with the Doyon site infrastructure. A number of ongoing monitoring programs and previous environmental studies have identified environmental impacts and have allowed IAMGOLD to determine the most effective mitigation and restoration strategies for the Project on completion of mining activities.

Major environmental studies and monitoring programs are summarized in Table 20-1.

Table 20-1: Major Environmental Studies

Study Type	Date	Comment
Closure plan	2016	Review and an assessment of closure alternatives for Westwood, Grand Duc, and Doyon. Supplemented with technical studies, which included hydrogeological, geochemical, and closure trade-off studies, dam stability and liquefaction assessments, borrow pits investigation and water quality modelling. Ministère de l'Énergie et des Ressources Naturelles approved in 2018.
	2021 update	Closure updates for Westwood, Grand Duc, and Doyon submitted to the Ministère de l'Énergie et des Ressources Naturelles . The ministry approved the closure plans in June–July 2024.
	2022	Review and an assessment of closure alternatives for Fayolle. Initial conceptual closure plan, which included hydrogeological, geochemical, and closure trade-off studies, dam stability and liquefaction assessments, borrow pits investigation and water quality modelling. Ministère de l'Énergie et des Ressources Naturelles approved the plan in 2022.
Hydrology	2009–2011	Completed in support of using mined-out Doyon open pit for tailings storage
Acid rock drainage		Geochemical testing and associated assessment of the waste and ore showed some material will generate acid.
Environmental effects monitoring		Used to assess the effectiveness of environmental management measures, by evaluating the effects of effluents on fish, fish habitat, and the use of fisheries resources by humans. Six study cycles have been completed, and the seventh is underway. All studies are submitted to the federal Ministry of Environment and Climate Change for approval.
Environmental baseline	2019–2024	Climate, air quality, hydrology and surface water quality, hydrogeology, flora, fauna, soils, agriculture, and land use baseline studies including modelling.

The following environmental management measurements have been implemented:

- The Mining Association of Canada Towards Sustainability Mining Program is in place. This process is audited internally on an annual basis and every three years by an external auditor.
- The IAMGOLD Health and Safety Management System is in place.
- An emergency plan and response team are in place.
- IAMGOLD Westwood is a member of the Institut de recherche en mines et environnement and collaborates with that organization with the goal of developing original and practical environmental solutions to the site-specific challenges during operation, closure, and post-closure period.

20.2.2 Water Management

20.2.2.1 Management Plan

The water management plan includes pit dewatering, waste rock runoff capture, diversion systems, and storage ponds. Water on site is classified into three categories:

- Non-contact water: runoff from undisturbed areas, including flow in the Paré Creek, Bousquet Creek and Bousquet River;
- Contact water: runoff from disturbed areas, underground and open pits, which may contain suspended solids or liquids contaminants (e.g., metals, pH);
- Process water: water mixed in the process plant and recovered from the TSF (thickeners/basin and dewatering pumps).

20.2.2.2 Plan Objectives

Key objectives for water management are as follows:

- Avoid water contact with disturbed areas;
- Minimize water withdrawal from surface and ground water sources;
- Maximize water recirculation;
- Prevention or early detection of leaks/spills;
- Meet environmental expectations as defined in permits or regulations.

20.2.2.3 Mine Water Pond

The Westwood pond was designed and built in compliance with the Certificate of Authorization. Wastewater is collected at the Westwood mine water pond, which has a capacity of 7,200 m³. Wells have been installed around the mine water pond to monitor the groundwater quality.

20.2.2.4 Effluent Management System

All water collected in the Doyon, Grand Duc, and Westwood areas is pumped to the water management system for treatment, as required, treated via a high density sludge plant, and then discharged to the Bousquet River. The final effluent discharged is regulated by a depollution attestation (incorporating all

of the Doyon and Westwood Certificates of Authorization) under the *Environment Quality Act*, which is managed by the provincial government and also the federal *Fisheries Act*, Section 36, Metal and Diamond Mining Effluent Regulations, which is managed by the federal Ministry of Environment and Climate Change (including environmental effects monitoring studies and toxicity testing). The combined effluent (i.e., Doyon runoff, Westwood mine operations and Grand Duc open pit dewatering) is monitored to ensure that all applicable environmental criteria are consistently met prior to discharge to the environment.

All water collected in the Fayolle area is pumped to the water management system for treatment, as required, treated via a lime + flocculant water treatment plant, and then discharged to Paré Creek. The final effluent discharged is regulated by the Fayolle Mine Certificate of Authorization under the *Environment Quality Act* and by the federal *Fisheries Act*. The effluent is monitored to ensure that all applicable environmental criteria are consistently met prior to discharge to the environment.

20.2.2.5 Acid Rock Drainage

Collection ditches are in place around the disturbed areas to collect surface runoff and seepage from current and past infrastructure. Water collected in the ditches is pumped to the Doyon/Westwood reservoirs and then excess water is sent to a high density sludge treatment plant and polishing pond prior to final discharge.

20.3 Mine Closure Requirements and Costs

Closure plans must be submitted to the relevant regulator before commencement of activities. The Ministère de l'Énergie et des Ressources Naturelles reviews the plan, and in consultation with the Ministère de l'Environnement et de la Lutte contre les changements climatiques, approves the plan and its proposed implementation. The Ministère de l'Énergie et des Ressources Naturelles may, if necessary, request additional research or studies prior to issuing approval.

Closure plans must be revised every five years, however, in certain cases, the Ministère de l'Énergie et des Ressources Naturelles can require more frequent revisions. Such triggers can include a change in the nature of mining activities, the use of a new technology, or if the operator requests changes to the plan. All revised plans must be submitted to the Ministère de l'Énergie et des Ressources Naturelles for approval.

A financial guarantee is required to cover reclamation and closure costs. On 23 July, 2013, the Québec government approved amendments to the Regulation on Mineral Substances other than Petroleum,

Natural Gas and Brine (Règlement modifiant le Règlement sur les substances minérales autres que le pétrole, le gaz naturel et la saumure) that revised the financial guarantee provisions:

- Increased financial guarantees. Under the previous regulations, the financial guarantee that had to be provided to secure the mine restoration plan was set at 70% of the anticipated costs for the restoration of accumulation areas only. The amendments increase the guarantee requirement to 100% of the anticipated rehabilitation cost of the entire mine site;
- Basis for calculating the guarantee amount. The amount of the guarantee is based on the anticipated closure costs of the entire mine site and not only accumulation areas;
- The amendments propose that the financial guarantee be paid in three annual payments. The first payment would represent 50% of the total amount of the guarantee and is to be provided within 90 days of the approval of the restoration plan by the Ministère de l'Énergie et des Ressources Naturelles. The two subsequent payments would represent 25% of the total amount of the guarantee, and are to be provided on the first and second anniversary of the approval of the plan.

Once reclamation is completed under the approved plan, the site is secured, and no longer presents a risk of acid rock drainage, the Ministère de l'Énergie et des Ressources Naturelles will issue a certificate to indicate that the company is released from its obligations. The same release is granted if a third party agrees to assume the closure obligations.

The most recent closure plan update was submitted for Westwood and Doyon in 2021, with separate closure plans for each of Doyon and Westwood. The combined closure costs for Westwood, Doyon/Grand Duc and Fayolle, including contingency and ongoing Doyon care and maintenance costs, are estimated to be approximately \$223.7 million. The 2021 Westwood closure plan was approved by the ministry in June 2024 and IAMGOLD has provided financial guarantees of \$54.2 million to date in accordance with the government's payment schedule, increasing to \$57.24 million by 2026. The Doyon/Grand Duc closure plan was approved by the ministry in July 2024 and IAMGOLD provided financial guarantees of \$97.0 million to date in accordance with the government's payment schedule, increasing to \$122.13 million by 2026. The Fayolle closure plan was approved by the ministry in 2022 and IAMGOLD provided financial guarantees of \$2.3 million in accordance with the government's payment schedule, increasing to \$3.01 million by December 19, 2024. The final Fayolle closure plan is required no later than 19 December, 2027.

A history of the closure plan approvals and updates, together with the financial guarantees paid, is provided in Table 20-2. The amounts presented in Table 20-2 were set in Canadian dollars and have been converted to US dollars using a US\$/C\$ exchange rate of 1.35.

Table 20-2: Closure Plans and Updates

Plan	Closure Plan Approval/Update	Note
Doyon	Originally submitted in December 1999. Revised December 2004 and approved December 2006. Revised December 2009 and approved March 2012 2014: Regulations update. Financial guarantees increase from 70% to 100% of the total cost estimate	2006: \$19.56 million cost estimates (70% financial guarantees provided as required by regulation) 2012: \$72.15 million cost estimates (70% financial guarantees provided as required by regulation)
Westwood	Originally submitted in December 2009 and approved in July 2012. April 2014: Regulations update. Financial guarantees increase from 70% to 100% of the total cost estimate. Revised January 2015 and approved December 2015.	2012: \$0.35 million cost estimates (70% financial guarantees provided as required by regulation) 2014: \$1.85 million cost estimates (100% financial guarantees provided as required by regulation) 2015: \$2.66 million in financial guarantees (70% financial guarantees provided as required by regulation)
Grand Duc	Originally submitted in February 2016, approved July 2016. Grand Duc subsequently included in Doyon closure plan updates	2016: \$0.06 million in financial guarantees
Westwood and Doyon	Updated plan provided October 2016. Integrated Westwood Operations with the former Doyon infrastructure based on current and future use. Some mine components originally in the Doyon plan were transferred to Westwood. Closure plans approved in February 2018. Updated 2021, with separate closure plans for Doyon and Westwood. Westwood is in operation, and Doyon is in the post-closure phase. Closure plans were approved in June and July 2024.	2018: \$48.52 million in financial guarantees for Westwood; \$71.96 million in financial guarantees for Doyon. 2021: IAMGOLD cost estimate submitted in the 2021 update: \$53.63 million in financial guarantees for Westwood; \$115.26 million in financial guarantees for Doyon. 2024: \$57.24 million in financial guarantees for Westwood; \$122.13 million in financial guarantees for Doyon.
Fayolle	Originally submitted in March 2022 and approved December 2022. Update required no later than 19 December, 2027.	2022: \$3.01 million in financial guarantees for Westwood.

Activities included in the Doyon, Westwood and Fayolle closure plans include:

- Underground closure;
- Closure of open pits;
- Demolition and rehabilitation of plant sites and infrastructures;
- Rehabilitation of all roads and pads;
- Rehabilitation of all TSFs;
- Rehabilitation of all WRSFs;
- Rehabilitation of all ponds and reservoir;
- Acid rock drainage management and rehabilitation of areas contaminated with acid-generating rock;
- General revegetation;
- Environmental compliance and monitoring.

20.4 Permitting

20.4.1 Initial Permitting

Prior to the start of operations at the Westwood and Grand Duc Mines, the Doyon operations held all of the environmental permits required to operate the Doyon underground mine, Doyon open pit, process plant, water treatment plant and tailings/waste rock pile. The closure plan was approved by the Ministry of Natural Resources. Mining leases were granted. Explosives permits were received from the Sûreté du Québec.

20.4.2 Current Permitting

Table 20-3 is a list of the key permits required to support the Project. Permit applications and renewals are undertaken as required. As at 3 August 2024, all material permits were in compliance or were in the analysis or renewal process. A review indicated that some permits were missing from the Doyon closure process. IAMGOLD is undertaking new requests or plans to lodge modification of existing permits requests to address this issue.

Table 20-3: Key Permits

Permit Type	Purpose	Date Granted	Date Expiry	Note
Mining lease	Mining lease 695 (Doyon)	3 July, 1980	2 July, 2030	
Waste water treatment authorisation	Treatment of mining wastewater – development of the Westwood project	4 July, 2008	No expiry date	
Modification of certificate of authorization	Operation of the mine and operation of the Doyon Mine gold ore processing plant and related facilities	18 May, 2011	No expiry date	
Modification of certificate of authorization	The operation of an HDS plant as well as the disposal of liming sludge	18 May, 2011	No expiry date	
Modification of certificate of authorization	Tailings site, Doyon mine	18 May, 2011	No expiry date	
Modification of certificate of authorization	Ore extraction-Westwood project	18 May, 2011	No expiry date	
Certificate of authorization	Modernization of the processing plant	31 May, 2011	No expiry date	
Certificate of authorization	Installation of two ore piles	13 June, 2011	No expiry date	
Waste water treatment authorisation (Q-2)	Wastewater treatment - Westwood project	15 September, 2011	No expiry date	
Certificate of authorization	Use of the Doyon pit as a tailings site	7 March, 2012	No expiry date	
Mining lease	Mining lease 1002 (Westwood)	23 April, 2012	22 April, 2032	
Permission change	Construction of a domestic wastewater treatment system	23 May, 2012	No expiry date	

Permit Type	Purpose	Date Granted	Date Expiry	Note
Authorization (Q-2)	Groundwater catchment - Westwood project	2 August, 2012	14 August, 2024	The renewal request was submitted to ministry and the current authorization remains valid until the approval of the renewal
Sanitation certificate	Sanitation certificate	19 March, 2013	No expiry date	
Certificate of authorization	Raising of tailings ponds	20 February, 2014	No expiry date	
Modification of decontamination certificate	Mining	12 January, 2015	No expiry date	
Certificate of authorization	Ore custom processing	1 February, 2016	No expiry date	
Approval of the Grand Duc closure plan	Closure plan	13 July, 2016		
Explosives Permit	Surface and underground explosives depots	22 August, 2023	21 August, 2028	Explosives Permit
Certificate	Certificate of conformity for oil tanks	10 March, 2020	14 December, 2025	
License for nuclear substances and radiation devices	Permits for nuclear sources (density meters)	26 May, 2020	30 April, 2026	Permit number 14514-1-26.0
Certificate of authorization	Modernization of the treatment plant	27 January, 2021	No expiry date	1.7 Mt/a
Certificate of authorization	Operation of a mobile crusher	21 September, 2021	No expiry date	

Permit Type	Purpose	Date Granted	Date Expiry	Note
Permit	High risk petroleum equipment permit	30 December, 2021	No expiry date	
Certificate of authorization	Bulk sampling	22 March, 2022	No expiry date	Grand Duc Phase 2
Authorization Certification	Restoration of tailings pond No. 1 of the Westwood/Doyon mine	18 July, 2022	No expiry date	Article 128.7
Authorisation	Work in fish habitat – Provincial	3 August, 2023	No expiry date	CE-1 and Paré streams
Ministerial authorization	Reactivation of the Doyon North WRSF	23 November, 2023	No expiry date	
Authorisation	Authorization - Fisheries Act	3 August, 2023	No expiry date	
Surface lease	Surface lease	8 February, 2023	Annual	
Certificate of authorization	Fayolle mine exploitation and valorisation of waste rock as aggregate	16 February, 2023	No expiry date	
Mining lease	Mining lease	20 February, 2023	20 February, 2033	
Redevelopment and closure plan	Westwood redevelopment and closure plan	December 2009	5 year renewal	
Redevelopment and closure plan	Doyon–Grand Duc redevelopment and closure plan	December 1999	5 year renewal	

20.4.2.1 Westwood

In October 2017, IAMGOLD submitted a renewal request with the Ministère de l'Environnement et de la Lutte contre les changements climatiques as required by the governing legislation. The latest version of the depollution attestation will remain valid until approval or rejection is received as defined by the legislation. Since the latest Depollution Attestation, the site has received the key authorizations, with the most relevant being:

- The process plant capacity was modified from 3,200 t/d to 4,660 t/d in 2021;
- The Doyon North WRSF was reactivated, and has a 9 Mt of permitted additional storage capacity;
- An authorization to operate a mobile crusher for ore, waste and concrete waste was granted, which allows for operational flexibility.

In October 2021, closure plans for Westwood–Doyon–Grand Duc were submitted to the appropriate regulators, and were approved in June–July 2024.

In July 2023, IAMGOLD Westwood mine submitted a renewal request for the explosives permits to the appropriate regulators. This was approved on 22 August, 2023.

In 2019, IAMGOLD initiated the permitting process for the progressive reclamation of the old Doyon tailing storage facility # 1 and obtained the permits in mid-2022. In 2023, IAMGOLD initiated the reclamation works and the ongoing reclamation works are expected to be completed after 2026.

20.4.2.2 Grand Duc

In 2019, operations at Grand Duc began in accordance with a 2006 Certificate of Authorization and a 2016 closure plan. In November 2020, the Grand Duc Phase 1 Expansion Certificate of Authorization was approved, with the Grand Duc Phase 2 Expansion Certificate of Authorization being approved in March 2022. As required by the Ministry, the 2021 Grand Duc closure plan update was included in the 2021 Doyon mine closure plan update.

20.5 Waste Rock Storage Facilities

The Westwood WRSF was constructed in accordance with the Certificate of Authorization, which is based on the guidelines of Directive 019 established by the Ministère de l'Environnement et de la Lutte contre les changements climatiques. The Westwood WRSF has a capacity of 45,000 m³, and is lined with a high

density polyethylene liner to limit infiltration of water into the ground, minimizing the potential for contamination of groundwater in the area. Groundwater wells and surface water collection ditches have been installed around the Westwood WRSF to monitor surface and groundwater quality.

Until 2019, waste rock was disposed in the Doyon South WRSF or Doyon open pit. Since 2020, all waste rock from Westwood and Grand Duc has been deposited in the Doyon South WRSF.

From 2021 to 2022, the former Doyon North WRSF as well as a sector to the north of Doyon were drilled. A request for a Certificate of Authorization to allow the reactivation of these areas for waste rock deposition was submitted to the Ministère de l'Environnement et de la Lutte contre les changements climatiques in December 2022, to increase the overall waste disposal capacity by 9 Mt. The Certificate of Authorization approval was received in November 2022. During the last phase of operation of the Grand Duc open pit, all waste materials will be placed in the Doyon North WRSF. There is sufficient capacity in the facility for the remaining Grand Duc LOM.

20.6 Tailings Storage Facility

In March 2012, the Québec Ministère de l'Environnement et de la Lutte contre les changements climatiques approved a Certificate of Authorization for the deposition and storage of Westwood tailings in the mined-out Doyon open pit. Placement of Westwood tailings commenced in 2014. The total capacity of the pit is estimated at 11.3 Mm³ of tailings and water at the targeted elevation of 4,954 m. The tailings are required to be covered by a minimum of 1 m of water and the water maximum target elevation is 4,956 m.

There is sufficient capacity within the former open pit to support the LOM plan tailings disposal requirements.

20.7 Social and Community Impact

20.7.1 First Nations

The Westwood and Grand Duc operations are in the territory identified in the agreement on consultation and accommodation between the government and the Council of the Abitibiwinni First Nation. IAMGOLD initiated discussions with the First Nations and is at the stage of concluding an agreement in principle with one First Nations community. The discussions remain ongoing until the signing of the final agreement.

20.7.2 Westwood and Grand Duc

No significant social challenges or opposition is expected as the majority of the infrastructure is located on or near the Doyon Mining Lease, which has been the subject of operations since 1980. As such, community and social impacts are regarded to be positive or unchanged. No new surface rights acquisitions were required during the development of the Westwood and Grand Duc mines as the location of the surface infrastructures was already held by IAMGOLD.

IAMGOLD conducts annual site visits and meetings with its local stakeholders, including representatives from the Rouyn-Noranda and Preissac municipalities, federal and provincial government ministries and elected officials, environmental groups, and community organizations. This outreach allows stakeholders to raise concerns about the impact of the current mining plan. In support of the Grand Duc mine, a monitoring committee was created and annual site visits and meetings have been completed in accordance with regulatory requirements.

Local benefits from the Westwood and Grand Duc operations include payment of municipal and school taxes, payment of mineral rights to the provincial government, local partnerships, contributions to charitable organizations, purchases and contracts with local businesses, and priority given to local employment in the operations. IAMGOLD has been recognized with awards for community participation from local organizations. IAMGOLD employee contributions to health and safety have also been acknowledged by the Québec Mining Association. Certain supervisors and those of their teams have been recognized for fostering and maintaining safe work environments over the period 2014–2024.

21 CAPITAL AND OPERATING COSTS

21.1 Introduction

The LOM plan assumes Owner-operated mining for the underground operations at Westwood, and is forecast from 2025–2032, to be aligned with IAMGOLD’s budgetary exercises. The LOM plan uses the same Mineral Reserve forecast for the last six months of 2024. The Grand Duc open pit operations are conducted by contractors, with mining planned to end in 2025.

As Westwood and Grand Duc are currently operating, the costs are primarily based on actual operating and capital costs.

21.2 Capital Cost Estimates

21.2.1 Exploration, Valuation, and Definition Drilling

Exploration campaigns to date have focused on estimating Mineral Resources to a depth of 2,400 m, the maximum depth that can be mined with the infrastructure currently planned. In the recent years, most of the drilling has targeted resources above 1,800 m in depth. Future exploration will be focused on diamond drilling intended to support potential upgrade of Inferred Mineral Resources to higher confidence categories and test several prospects.

The LOM plan contains allocations of \$2.1 million for valuation, and \$9.4 million for definition drilling.

21.2.2 Underground Infrastructure

Underground infrastructure costs include lateral development (e.g., ramps, accesses, and sills), vertical development (e.g., ore passes, ventilation raises, escapeways) and construction of underground infrastructure s (e.g., refuge stations, electrical substations, escapeways, and extensions to the ventilation and pastefill networks). Equipment costs are included for fixed installations such as electrical substations, cable networks, fans, and mobile equipment to replace the fleet as it ages.

21.2.3 Process Plant

Planned capital expenditure is mainly related to process and equipment reliability improvements. No capital expenditure is planned to significantly upgrade or increase process plant throughput.

21.2.4 Closure Costs

Closure costs are presented in Table 20-2 in Section 20.3.

21.2.5 Capital Cost Estimate Summary

The LOM capital costs for Westwood are summarized in Table 21-1. Mine closure costs provided in Section 20.3 are not included in the table.

21.3 Operating Costs

21.3.1 Mining

Mining costs at Westwood Mine are the most significant component of the operating costs, and include all underground mining activities as well as the direct services required to support the operation. The operating costs include labor and materials:

- Underground general services: includes costs of labor and materials to operate and maintain the mine;
- Underground development and rehabilitation: include the costs to access, maintain, and activate new production fronts;
- Underground production: includes the costs related to mining stopes and the transport of material to the shaft;
- Maintenance: includes costs related to maintaining equipment and infrastructure;
- Surface transport and services: includes costs of transporting material from Westwood to the mill and maintaining the site;
- Technical services: includes the costs of the engineering, geology, and ground control teams required for the design, monitoring, and planning of operations;
- Definition drilling: includes the drilling and assays required to refine the grade and tonnage estimates for stopes prior to mining.

Grand Duc costs include estimates for the contract mining, rehandling, fuel, materials, and technical services.

Table 21-1: Summary of Capital Expenditures, Westwood (\$ million)

Item	2025	2026	2027	2028	2029	2030	Total
Buildings	2.2	1.0	2.6	—	—	—	5.8
Construction underground	4.6	4.0	4.3	4.6	4.4	4.7	26.5
Development	31.7	18.8	21.8	19.2	11.8	11.3	114.6
Fixed equipment (surface)	4.9	0.4	0.4	0.1	3.8	-	9.7
Fixed equipment (underground)	6.3	5.5	5.9	0.1	2.2	1.6	21.6
Mill equipment	5.9	6.6	3.9	2.9	2.3	2.3	24.0
Mobile equipment	11.5	13.7	12.3	5.7	3.2	0.5	46.8
Other equipment	1.3	0.8	0.7	0.4	0.5	0.5	4.2
Surface drilling	-	-	-	-	-	-	-
Tailings	4.3	0.9	0.7	-	-	-	5.9
Underground core drilling	1.6	-	-	-	-	-	1.6
Total	74.3	51.6	52.6	32.9	28.3	20.8	260.7

Note: Numbers have been rounded.

21.3.2 Processing

The processing costs include labour, consumables, power consumption, crushing, laboratory testing, and process plant maintenance costs:

- Labour costs;
- Operating consumables including crusher and mill liner costs, grinding media, screen wear parts, reagent consumption costs (lime, sodium cyanide, carbon, flocculant, elution and gold room reagents, diesel fuel for mobile equipment);
- Services costs including the laboratory, rentals, consultants, and other minor services;
- Maintenance costs including mechanical, electrical, and light vehicle maintenance related to the process plant.

21.3.3 Environmental

Direct environmental costs include departmental operations, waste management, testing, and compliance costs.

Doyon post-closure costs are not included in the Westwood Operations costs.

Tailings and water management costs are included in processing costs.

21.3.4 Administration

Administration costs include labour and expenses related to general management, health and safety, human resources (including training), administration (accounting), procurement, continuous improvement, and information technology.

21.3.5 Operating Cost Estimate Summary

Life-of-mine operating costs are summarized in Table 21-2 for Westwood and Grand Duc.

Table 21-2: Westwood Complex – Mine Plan Summary

	Units	LOM Total or Average	2025	2026	2027	2028	2029	2030	2031	2032
Mining Operations										
<i>Westwood Underground</i>										
Ore mined	000 t	2,496	351	346	370	373	374	359	275	48
Grade mined	g/t Au	11.55	11.04	13.25	11.86	10.60	11.29	10.20	12.68	13.62
<i>Grand Duc Open Pit</i>										
Ore mined	000 t	1,129	1,129	—	—	—	—	—	—	—
Grade mined	g/t Au	1.10	1.10	—	—	—	—	—	—	—
Waste mined	000 t	1,059	1,059	—	—	—	—	—	—	—
Total mined	000 t	2,189	2,189	—	—	—	—	—	—	—
Processing										
Ore milled, underground	000 t	2,496	351	346	370	373	374	359	275	48
Ore milled, open pit	000 t	1,544	724	742	79	—	—	—	—	—
Ore milled	000 t	4,040	1,075	1,088	449	373	374	359	275	48
Head grade, underground	g/t Au	11.55	11.04	13.25	11.86	10.60	11.29	10.20	12.68	13.62
Head grade, open pit	g/t Au	0.98	1.35	0.66	0.66	—	—	—	—	—
Head grade	g/t Au	7.51	4.52	4.66	9.90	10.60	11.29	10.20	12.68	13.62
Recovery	%	95	94	95	95	95	95	95	95	95
<i>Gold production</i>	<i>000 oz</i>	<i>925</i>	<i>147</i>	<i>154</i>	<i>136</i>	<i>121</i>	<i>129</i>	<i>112</i>	<i>107</i>	<i>20</i>
Operating Cost										
Mining cost, underground	\$M	631.0	95.8	85.1	92.3	93.0	93.3	90.3	69.2	12.0

	Units	LOM Total or Average	2025	2026	2027	2028	2029	2030	2031	2032
Mining cost, open pit	\$M	15.4	14.3	0.9	0.1	—	—	—	—	—
Mining cost	\$M	646.4	110.1	86.0	92.4	93.0	93.3	90.3	69.2	12.0
Process cost	\$M	155.0	28.0	29.0	21.8	19.8	19.9	19.2	14.7	2.5
General and administrative cost	\$M	167.8	20.5	20.7	21.0	21.0	21.0	21.2	21.2	21.2
Total	\$M	969.2	158.7	135.7	135.2	133.8	134.2	130.7	105.2	35.7
Unit Costs										
Mining cost, underground	\$/t mined	252.78	272.95	245.70	249.48	249.48	249.48	251.41	251.41	251.41
Mining cost, open pit	\$/t mined	6.55	6.55	—	—	—	—	—	—	—
Mining cost	\$/t processed	160.00	102.49	79.07	206.01	249.48	249.48	251.41	251.41	251.41
Process (incl. environmental) cost	\$/t processed	38.37	26.09	26.68	48.56	53.12	53.12	53.53	53.53	53.53
General and administrative cost	\$/t processed	41.54	19.10	19.03	46.85	56.40	56.18	58.97	76.91	445.54
Capital Expenditures										
Sustaining capital expenditures	\$M	260.7	74.3	51.6	52.6	32.9	28.3	20.8	0.0	0.0
Non-sustaining capital expenditures	\$M	0.0	0.0	0.0	0.0	0.0	0.0	0.0	0.0	0.0
Total capital expenditures	\$M	260.7	74.3	51.6	52.6	32.9	28.3	20.8	0.0	0.0

Note: Numbers have been rounded.

22 ECONOMIC ANALYSIS

IAMGOLD is using the provision for producing issuers, whereby producing issuers may exclude the information required under Item 22 for technical reports on properties currently in production and where no material production expansion is planned.

Mineral Reserve declaration is supported by a positive cashflow.

23 ADJACENT PROPERTIES

This section is not relevant to this Report.

24 OTHER RELEVANT DATA AND INFORMATION

This section is not relevant to this Report.

25 INTERPRETATION AND CONCLUSIONS

25.1 Introduction

The QPs note the following interpretations and conclusions in their respective areas of expertise, based on the review of data available for this Report.

25.2 Project Setting

The Project is located in the province of Québec, Canada. Mining operations are conducted year-round. Weather conditions have minimal impacts on the mining operations; however, heating is required in winter to keep ventilation infrastructures and ore bins free of ice, and to heat the Westwood underground mine.

Materials and supplies for mining operations are brought into the sites via road. Skilled and experienced workers (miners and technical staff) are readily available.

There are no significant topographic or physiographic issues that would affect the operations.

25.3 Ownership

IAMGOLD holds a 100% interest in the Project.

25.4 Mineral Tenure, Surface Rights, Water Rights, Royalties and Agreements

The mineral tenure held is valid, and is sufficient to support Mineral Resource and Mineral Reserve estimation.

Surface and water rights are granted, and sufficient to support mining operations.

The Doyon-Westwood property is not subject to any royalties or any other encumbrances.

25.5 Geology and Mineralization

The deposit types within the Project area are considered to be examples of greenstone-hosted orogenic gold deposits. The Westwood and Grand Duc deposits also include characteristics of gold-rich VMS deposits.

The geological understanding of the settings, lithologies, and structural and alteration controls on mineralization in the different zones is sufficient to support estimation of Mineral Resources and Mineral Reserves. The geological knowledge of the area is also considered sufficiently acceptable to reliably inform mine planning.

The mineralization style and setting are well understood and can support declaration of Mineral Resources and Mineral Reserves.

25.6 History and Exploration

The exploration programs completed to date are appropriate for the style of the deposits within the Project area.

25.7 Drilling, and Sampling

Sampling methods are acceptable for Mineral Resource and Mineral Reserve estimation.

Sample preparation, analysis and security are generally performed in accordance with exploration best practices and industry standards.

The quantity and quality of the lithological, geotechnical, collar and down-hole survey data collected during the exploration and delineation drilling programs are sufficient to support Mineral Resource and Mineral Reserve estimation. The collected sample data adequately reflect deposit dimensions, true widths of mineralization, and the deposit style. Sampling is representative of the gold grades, reflecting areas of higher and lower grades.

The QA/QC programs adequately address issues of precision, accuracy, and contamination.

25.8 Data Verification

The data verification programs concluded that the data collected adequately support the geological interpretations and constitute a database of sufficient quality to support the use of the data in Mineral Resource and Mineral Reserve estimation.

25.9 Metallurgical Testwork

Industry-standard studies were performed as part of process development and initial mill design. Subsequent production experience and focused investigations guided mill alterations and process

changes. Testwork programs, both internal and external, continue to be performed to support current operations and potential improvements. From time to time, this may lead to requirements to adjust cut-off grades, modify the process flowsheet, or change reagent additions and plant parameters to meet concentrate quality, production, and economic targets.

Samples selected for testing were representative of the various types and styles of mineralization in the Westwood and Grand Duc deposits. Sufficient samples were taken so that tests were performed on sufficient sample mass.

Recovery factors estimated are based on appropriate metallurgical testwork, and are appropriate to the mineralization types and the selected process route.

The mill throughput and associated recovery factors are considered appropriate to support Mineral Resource and Mineral Reserve estimation, and mine planning.

There are no known deleterious elements in the LOM plan that would be expected to affect metallurgical recoverability or product saleability.

25.10 Mineral Resource Estimates

Mineral Resources are reported with an effective date of 30 September, 2024 using the Mineral Resource definitions set out in the 2014 CIM Definition Standards, and are reported in situ, inclusive of those Mineral Resources converted to Mineral Reserves. Mineral Resources that are not Mineral Reserves do not have demonstrated economic viability.

Areas of uncertainty that may materially impact the Mineral Resource estimates include: changes to long-term gold price assumptions; changes in local interpretations of mineralisation geometry and continuity of mineralised zones; changes to geological shape and continuity assumptions; changes to metallurgical recovery assumptions; changes to the operating cut-off assumptions for assumed long hole mining operations at Westwood; changes to the inputs to the constraining pit shell used for Grand Duc; changes to the input assumptions used to derive the conceptual underground outlines used to constrain the Westwood estimate; changes to the cut-off grades used to constrain the Westwood estimate; changes to the cut-off grade used to report the Grand Duc estimate; variations in geotechnical, hydrogeological, and mining assumptions; changes to environmental, permitting and social license assumptions; and changes to legal, political, title-related, taxation, socio-political, or marketing assumptions.

25.11 Mineral Reserve Estimates

Mineral Reserves are reported using the Mineral Reserve definitions set out in the 2014 CIM Definition Standards, and are reported at the point of delivery to the process plant.

Factors that may affect the Mineral Reserve estimate include:

- The gold price influences Mineral Reserves, and its increase or decrease significantly impacts the cut-off grade and forecast cashflow outcomes;
- Geotechnical constraints must be rigorously respected in mining sequences. At the same time, the implementation of the Westwood algorithm allows all zones to be opened, which increases Mineral Reserves;
- Seismicity always represents a risk, but geotechnical strategies and tactics reduce this risk and allow for safe mining;
- Mining recovery and dilution are factors that directly influence the Mineral Reserves estimates. Even small changes in dilution can affect mining recoveries, and hence the ounces in the material delivered to the process plant;
- The mining cost factor influences the cut-off grade and the Mineral Reserve estimates;
- Process recovery is an element that impacts Mineral Reserves estimate, and maintaining LOM process recoveries at around 95% will represent a challenge. This challenge is being mitigated by the proposed capital investment plan.

The QP is of the opinion that Mineral Reserves were estimated using industry-accepted practices, and conform to the 2014 CIM Definition Standards.

The mine design has undergone significant changes to adhere to geotechnical recommendations regarding mining sequences while maintaining the long-hole stoping method. The sequences are based on a geotechnical algorithm implemented due to a better understanding of the mine's structures and rock mechanics. These changes significantly reduce seismicity and increase mining safety. The mining sequence is tailored to accommodate the geotechnical conditions encountered during operations.

There are no other environmental, legal, title, taxation, socioeconomic, marketing, political or other relevant factors known to the QP that would materially affect the estimation of Mineral Reserves that are not discussed in this Report.

The QP is not aware of any additional mining, metallurgical, infrastructure, permitting, or other factors not presented in this report that could materially affect the Mineral Reserve estimate.

25.12 Mining Methods

Mineral Reserves were estimated for Westwood assuming conventional long-hole stoping mining methods, and the use of conventional Owner-operated equipment. The operations will be completed in 2032 based on current reserve estimates.

Mineral Reserves were estimated for Grand Duc assuming open pit mining, and the use of conventional contractor-operated equipment. The mining operations will be completed in 2025, and milling in 2027.

25.13 Recovery Methods

The process plant design was based on a combination of metallurgical testwork, previous study designs, previous operating experience. The design is conventional to the gold industry and has no novel parameters.

The plant has been operated both continuously, and in batch mode, since 2013, depending on ore availability. Currently, operations are 24 hours a day, seven days a week, 52 weeks a year. However, there will be portions of the current mine plan which will see reduced ore availability, and the plan is to have the plant operate in batch mode. Depending on the period, this may result in selected weeks in a month operations, or 3–4 days in a week operation.

There have also been instances over the plant history where the process plant toll-treated custom material from other mining operations. This remains an option since the process flowsheet is flexible and can accommodate third-party custom materials outside the LOM plan.

The plant will produce variations in recovery due to the day-to-day changes in ore type or combinations of ore type being processed. These variations are expected to trend to the forecast recovery value for monthly or longer reporting periods.

25.14 Infrastructure

Infrastructure to support mining operations is in place, and operational.

The power supply is sufficient for LOM operations.

25.15 Market Studies

Gold produced from the Westwood Complex is shipped to the Metalor refinery in Massachusetts (USA) and sold at spot prices. The refining contract and sales schedules are managed by IAMGOLD at the corporate level, and include production from other operations. The terms contained within the sales contracts are typical and consistent with standard industry practice, and are similar to contracts for the supply of doré elsewhere in the world.

Metal prices are set by IAMGOLD management and are appropriate to the commodity and mine life projections.

25.16 Environmental, Permitting and Social Considerations

Baseline and supporting environmental studies were completed prior to operations start-up. Currently, IAMGOLD is completing characterizations as, and when, new applications for environmental authorization are required. The available environmental studies documenting pre-existing conditions, together with the ongoing site environmental conditions monitoring, are used to support decision-making processes during operations.

The most recent closure plan for Westwood–Doyon was submitted in 2021. The 2021 Westwood closure plan was approved by the ministry in June 2024 and the financial guarantee was set at \$57.24 M. The Doyon/Grand Duc closure plan was approved by the ministry in July 2024 and the financial guarantee was set at \$122.13 M. The next planned updates for Doyon and Westwood are July and June 2029, respectively.

All major permits and approvals are either in place or IAMGOLD expects to obtain them in the normal course of business. Where permits have specific terms, renewal applications are made of the relevant regulatory authority as required, prior to the end of the permit term. In 2019, IAMGOLD initiated the permitting process for the progressive reclamation of the old Doyon tailing storage facility # 1 and obtained the permits in mid-2022. In 2023, IAMGOLD initiated the reclamation works and the ongoing reclamation works are expected to be completed after 2026.

The Westwood and Grand Duc operations are in the territory identified in the agreement on consultation and accommodation between the government and the Council of the Abitibiwinni First Nation. IAMGOLD initiated discussions with the First Nations and is at the stage of concluding an agreement in principle with one First Nations community. The discussions remain ongoing until the signing of the final agreement.

No significant social challenges or opposition are expected for the Westwood or Grand Duc operations based on the LOM plan presented in this Report.

25.17 Capital Cost Estimates

The LOM plan assumes Owner-operated mining for the underground operations at Westwood, with mining and processing extending through to 2032. The Grand Duc open pit operations are conducted by contractors, with mining planned to end in 2025.

LOM capital costs are estimated at \$260.7 million for Westwood.

25.18 Operating Cost Estimates

As Westwood and Grand Duc are currently operating, the costs are primarily based on actual operating costs.

LOM operating costs on a unit basis are estimated to be \$365.66/t milled at Westwood and \$36.57/t milled at Grand Duc.

25.19 Economic Analysis

IAMGOLD is using the provision for producing issuers, whereby producing issuers may exclude the information required under Item 22 for technical reports on properties currently in production and where no material production expansion is planned.

Mineral Reserve declaration is supported by a positive cashflow.

25.20 Risks and Opportunities

25.20.1 Risks

Factors that may affect the Mineral Resource estimates are outlined in Section 14.4. Factors that may affect the Mineral Reserve estimates are summarized in Section 15.5.

IAMGOLD has spent considerable time, effort, and capital to address the seismic issues that resulted in the temporary mine closure in 2021. IAMGOLD intends to continue the rigorous application of its ground control algorithm to minimize seismic risks.

The main risk to the Project as presented in this Report is considered to be cost management. To achieve the costs used in the economic model that supports the Mineral Reserves, operations will have to monitor:

- Expenditure required to maintain aging fixed infrastructure and mobile equipment;
- Underground development, stope access, and ore delivery to the process plant occurring as scheduled;
- Labour availability given the Westwood Complex is in an area where a number of mines are competing for trained personnel.

25.20.2 Opportunities

The Westwood deposit remains open at depth, westward and locally to the east along the untested mineralized Westwood, North and Zone-2 corridors.

The Grand Duc deposit remains open westward and locally to the east.

Exploration potential remains around the former Doyon mine.

There is upside opportunity if the Indicated Mineral Resources that were not converted to Mineral Reserves can be converted with higher gold prices.

There is additional upside opportunity if Inferred Mineral Resources can be upgraded to higher confidence categories with more drilling and supporting studies.

There is also upside opportunity if prospects in proximity to the mining operations or more regional prospects can support Mineral Resource estimation, with additional technical data collection and related studies.

25.21 Conclusions

An economic analysis was performed in support of estimation of the Mineral Reserves; this indicated a positive cash flow using the assumptions detailed in this Report.

26 RECOMMENDATIONS

As the Westwood Complex is an operating mine, and risks identified in Section 14 (Mineral Resources), Section 15 (Mineral Reserves) and Section 25 (LOM plan) will be managed as part of normal operations, the QPs have no meaningful recommendations to make.

27 REFERENCES

- Barton, N., Lien, R., and Lunde, J.R.M., 1974: Engineering Classification of rock Masses for the Design of Tunnel support: Rock Mechanics, vol 6, pp.189–236.
- Beck, D., 2020: Simulation Of Westwood Mine Z2E Global Stability: report prepared by Beck Engineering Pty Ltd. for IAMGOLD.
- Belkibir, A., and Hubert, C., 1995: Geology and Structure of a Sulfide-Rich Gold Deposit; an Example from the Mouska Gold Mine, Bousquet district, Canada: Economic Geology, v. 90, pp. 1064–1079.
- Canadian Institute of Mining, Metallurgy and Petroleum (CIM), 2014: CIM Definition Standards For Mineral Resources And Mineral Reserves: adopted by the CIM Council on 10 May, 2014.
- Canadian Institute of Mining, Metallurgy and Petroleum (CIM), 2019: CIM Estimation Of Mineral Resources & Mineral Reserves Best Practice Guidelines: adopted by the CIM Council on 29 November, 2019.
- Canadian Securities Administrators, 2016: National Instrument 43-101, Standards Of Disclosure For Mineral Projects: 2016 compilation.
- Chown, E. H., Daigneault, R., Mueller, W., and Mortensen, J., 1992: Tectonic Evolution of the Northern Volcanic Zone of Abitibi Belt: Canadian Journal of Earth Sciences, v. 29, pp. 2,211–2,225.
- Deutsch, C.V. and Journel, A.G., 1997: GSLIB Geostatistical Software Library and User's Guide: Oxford University Press, New York, second edition. 369 p.
- École Polytechnique Montréal, 2008a: Essai De Laboratoire Projet Westwood: report prepared for IAMGOLD, March, 2008.
- École Polytechnique Montréal, 2008b: Mesure de Contrainte In-Situ à la Mine Doyon-Projet Westwood: report prepared for IAMGOLD, April 2008, 92 p.
- École Polytechnique Montréal, 2009: Essai De Laboratoire Projet Westwood: report prepared for IAMGOLD.
- Galley, A. and Lafrance, B. 2014: Setting And Evolution Of The Archean Syn-Volcanic Mooshla Intrusive Complex, Doyon-Bousquet-Laronde Mining Camp, Abitibi Greenstone Belt: Emplacement History, Petrogenesis And Implications For Au Metallogensis: Economic Geology. vol. 109; pp. 205–229.
- Goutier, J., 1997: Géologie de la région de Destor: Ministère des Ressources naturelles du Québec, RG 96-13, 37 p.

-
- Golder Associates 2008: Bousquet Fault Characterisation Data Integration And Preliminary Analysis: report prepared for IAMGOLD, October, 2008.
- Golder Associates 2009a: Technical Memorandum, Westwood Ore And Waste Pass Design Considerations: draft report prepared for IAMGOLD, May, 2009.
- Golder Associates, 2009b: Étude Hydrogéologique Pour La Déposition Des Résidus Dans Les Fosses Doyon: PowerPoint presentation prepared for IAMGOLD, August, 2009.
- Golder Associates, 2009c: CAWE_6_Figure Veins And Fault: PowerPoint presentation prepared for IAMGOLD, October, 2009.
- IAMGOLD Mine Doyon, 2009: Compte rendu de la rencontre avec Golder du 20 octobre 2009 sur la restauration et l'utilisation des fosses de la mine Doyon: internal IAMGOLD report, November, 2009.
- Jutras, M., 1988: Établissement D'un Modèle Géostatistique À La Mine Doyon, Canton Bousquet, Abitibi, Québec : mémoire de maîtrise es Sciences appliquées, Département de génie minéral, Université de Montréal, École Polytechnique, 99 p.
- Langshur, A., 1991: The Geology, Geochemistry and Structure of the Mooshla Intrusion, Bousquet Mining Centre, Quebec: M.Sc. thesis, Ottawa, Canada, University of Ottawa, 172 p.
- L'Observatoire de l'Abitibi-Témiscamingue, 2010: Carte sommaire de l'Abitibi-Témiscamingue: downloaded 19 October, 2011 from <http://www.observat.qc.ca/galerie-des-cartes>.
- Lafrance, B., Moorhead, J., and Davis, D.W., 2003 : Cadre géologique du camp minier de Doyon-Bousquet-LaRonde: Ministère des Ressources Naturelles et de la Faune du Québec, Report ET 2002-07, 44 p.
- Lavoie, T., 2019: Westwood Mine Z260-132 Back-Analysis: report prepared by Andrieux et Associates Geomechanics consulting, L.P. for IAMGOLD, 2019.
- Legault, M., Goutier, J., Beaudoin, G., and Aucoin, M., 2006: Metallogenic Synthesis of the Porcupine-Destor Fault, Abitibi Subprovince: Ministère des Ressources naturelles et de la Faune, ET 2006-01, 36 p.
- Mercier-Langevin, P., Dubé, B., Lafrance, B., Hannington, M.D., Galley, A., Moorhead, J., and Gosselin, P., 2007d, Metallogeny of the Doyon-Bousquet-LaRonde mining camp, Abitibi greenstone belt, Québec: Geological Association of Canada, Mineral Deposits Division Special Publication 5, p. 673–701.
- Mercier-Langevin, P., Wright-Holfeld, A., Dubé, B., Bernier, C., Houle, N., Savoie, A., and Simard, P., 2009, Stratigraphic setting of the Westwood-Warrenmac ore zones, Westwood project, Doyon-

-
- Bousquet-LaRonde mining camp, Abitibi, Québec: Natural Resources Canada, Current Research 2009-03, 20 p.
- Nadeau-Benoit, V., 2020: Project IMGwes19G127-IAMGOLD Geological and Structural Model Review: report prepared by Innov-Explo Inc. for IAMGOLD, 2020.
- Paudel, B. & Brummer, R., 2014: Assessment Of The Developments Stability at IAMGOLD Westwood Mine: report prepared for IAMGOLD, January 2014.
- Savoie, A., Trudel, P., Sauvé, P., Hoy, L.D., and Kheang, L., 1991, Géologie de la mine Doyon (région de Cadillac): Ministère des Ressources Naturelles et de la Faune du Québec, Report ET 90-05, 80 p.
- SGS, 2008a: An Investigation To Confirm The Metallurgical And Environmental Characteristics Of The Warrenmac Zone: report prepared for IAMGOLD, 17 October, 2008.
- SGS Lakefield, 2008b: An Investigation To Confirm The Metallurgical And Environmental Characteristics Of Warrenmac Zone Of Doyon Ore Body: report prepared for IAMGOLD, August, 2009.
- SGS, 2019: Grand Duc Tests métallurgiques; report prepared for IAMGOLD, 2019.
- URSTM, 2007a: Essais Métallurgiques Sur Le Minerai De Westwood: report prepared for IAMGOLD, August, 2007.
- URSTM, 2007b: Metallurgical Assays On The Ore At Westwood: report prepared for IAMGOLD, August, 2007.
- URSTM, 2007c: Metallurgical Assays On The Ore At Westwood: report prepared for IAMGOLD, September 2007.
- Wright-Holfeld, A., Mercier-Langevin, P., and Dube, B., 2010: Contrasting Alteration Mineral Assemblages Associated With The Westwood Deposit Ore Zones, Doyon-Bousquet-Laronde Mining Camp, Abitibi, Québec: Geological Survey of Canada: Current Research 2010-9, 25 p.
- Yergeau, D., 2015: Géologie Du Gisement Synvolcanique Aurifère Atypique Westwood, Abitibi, Québec: Ph.D. thesis. Institut National de la Recherche Scientifique – Centre Eau Terre Environnement, 682 p.
- Yergeau, D., , Mercier-Langevin, P., Dubé, B., Malo, M., McNicoll, V.J., Jackson, S.E., Savoie, A., and La Rochelle, F., 2015: The Archean Westwood Au Deposit, Southern Abitibi: Telescoped Au-Rich VMS-Type And Intrusion-Related Au Systems: *in* Targeted Geoscience Initiative 4: Contributions to the Understanding of Precambrian Lode Gold Deposits and Implications for Exploration, ed. B. Dube and P. Mercier-Langevin; Geological Survey of Canada, Open File 7852, pp. 177–191.
- Yergeau, D., Mercier-Langevin, P., Dubé, B., Malo M., and Savoie, A., 2022: The Neoproterozoic Westwood Deposit: Synchronous Formation Of Gold-Rich VMS-Type And Syn-Volcanic Intrusion-Related

Gold Mineralization, Abitibi Greenstone Belt, Québec – Part I. Geology, Lithogeochemistry, Petrogenesis, Deformation, and Metamorphism.

Yergeau, D., Mercier-Langevin, P., Dubé, B., McNicoll, V., Jackson, S.E., Malo, M., and Savoie, A., 2022: The Neoproterozoic Westwood Deposit: Synchronous Formation Of Gold-Rich VMS-Type And Syn-Volcanic Intrusion-Related Gold Mineralization, Abitibi Greenstone Belt, Québec – Part II. Hydrothermal Alterations and Ore Zones.